

**LAMPIRAN A**  
**BIODATA PENULIS**



Nama : Sukmandito

Tempat/tanggal lahir : Cilacap, 8 Juli 2001

Alamat : Perum Griya Wahana, Blok J1-10, Kel. Tritih Lor, Kec.  
Jeruklegi, Kab. Cilacap

Email : ditoemail88@gmail.com

Telepon : 087715207421

Motto : Jika dirimu merasa ingin menyerah, mengapa dirimu  
sangat berani untuk memulainya.

Riwayat Pendidikan :

| Sekolah                   | Jurusan      | Periode   |
|---------------------------|--------------|-----------|
| SDN 02 Cilacap            | -            | 2006-2013 |
| SMPN 8 Cilacap            | -            | 2013-2016 |
| SMK Dr. Soetomo Cilacap   | Pemesinan    | 2016-2019 |
| Politeknik Negeri Cilacap | Teknik Mesin | 2019-2023 |

**LAMPIRAN B**  
**TABEL DATA PENDUKUNG PERANCANGAN**

**Tabel 1** Harga *Sf1* dan *Sf2* (Sularso, 2008)

| Jenis Bahan                           | <i>Sf1</i> | <i>Sf2</i> |
|---------------------------------------|------------|------------|
| Bahan SF dengan kekuatan yang dijamin | 5,6        | 1,3-3,0    |
| Bahan S-C dan baja paduan             | 6,0        | 1,3-3,0    |

**Tabel 2** Sifat mekanis (SNI 07-2052-2002)

| Kelas baja tulangan | Nomor batang uji | Uji tarik  |   |              | Uji lengkung     |                                   |
|---------------------|------------------|--|---|--------------|------------------|-----------------------------------|
|                     |                  | Batas ulur<br>kgf/mm <sup>2</sup><br>(N/mm <sup>2</sup> )  | Kuat tarik<br>kgf/mm <sup>2</sup><br>(N/mm <sup>2</sup> ) | Regangan (%) | Sudut lengkung   | Diameter pelengkung               |
| BjTP 24             | No. 2            | Minimum 24<br>(235)  | Minimum 39<br>(380)                                       | 20           | 180 <sup>0</sup> | 3 x d                             |
|                     | No. 3            |  |   | 24           |                  |                                   |
| BjTP 30             | No. 2            | Minimum 30<br>(295)  | Minimum 45<br>(440)                                       | 18           | 180 <sup>0</sup> | d > 16 = 3xd                      |
|                     | No. 3            |  |   | 20           |                  | d > 16 = 4xd                      |
| BjTP 30             | No. 2            | Minimum 30<br>(295)  | Minimum 45<br>(440)                                       | 10           | 180 <sup>0</sup> | d ≤ 16 = 3xd                      |
|                     | No. 3            |  |   | 18           |                  | d > 16 = 4xd                      |
| BjTP 35             | No. 2            | Minimum 35<br>(345)  | Minimum 50<br>(490)                                       | 18           | 180 <sup>0</sup> | d ≤ 16 = 3xd                      |
|                     | No. 3            |  |   | 20           |                  | 16 < d ≤ 40 = 4xd<br>d ≥ 40 = 5xd |
| BjTP 40             | No. 2            | Minimum 40<br>(390)  | Minimum 57<br>(500)                                       | 16           | 180 <sup>0</sup> | 5 x d                             |
|                     | No. 3            |  |   | 18           |                  |                                   |
| BjTP 50             | No. 2            | Minimum 50<br>(490)  | Minimum 57<br>(620)                                       | 12           | 180 <sup>0</sup> | d ≤ 25 = 5xd                      |
|                     | No. 3            |  |   | 14           |                  | d > 25 = 6xd                      |
| CATATAN             |                  | 1. Hasil uji lengkung tidak boleh terletak pada sisi luar lengkung<br>2. Untuk baja tulangan sirip ≥ S.32 nilai renggang dikurangi 2 %<br>Untuk baja tulangan sirip S.40 dan S.50 dikurangi 4 % dari nilai yang tercantum pada tabel 6.<br>3. 1 kgf/mm <sup>2</sup> = 9,81 N/mm <sup>2</sup> |   |              |                  |                                   |

**Tabel 3** Sifat mekanik baja pegas daun JIS G 4801-1984 (Yamada, 2007)

| Steel grade | Heat treatment |             | Mechanical properties |                        |                                |                    |             |
|-------------|----------------|-------------|-----------------------|------------------------|--------------------------------|--------------------|-------------|
|             | Quench (C°)    | Temper (C°) | Yield strength (MPa)  | Tensile strength (MPa) | El. %<br>JIS No. 4<br>or No. 7 | RA. %<br>JIS No. 4 | Hardness HB |
| SUP3        | 830-860        | 450-500     | ≥ 834                 | ≥ 1079                 | ≥ 8                            | -                  | 341-401     |
| SUP6        | 830-860        | 480-540     | ≥ 1070                | ≥ 1226                 | ≥ 9                            | ≥ 20               | 363-429     |
| SUP7        | 830-860        | 480-540     | ≥ 1079                | ≥ 1226                 | ≥ 9                            | ≥ 20               | 363-429     |
| SUP9        | 830-860        | 460-510     | ≥ 1079                | ≥ 1226                 | ≥ 9                            | ≥ 20               | 363-429     |
| SUP9A       | 830-860        | 460-520     | ≥ 1079                | ≥ 1226                 | ≥ 9                            | ≥ 20               | 363-429     |
| SUP10       | 840-870        | 470-640     | ≥ 1079                | ≥ 1226                 | ≥ 10                           | ≥ 30               | 363-429     |
| SUP11A      | 830-860        | 460-520     | ≥ 1079                | ≥ 1226                 | ≥ 9                            | ≥ 20               | 363-429     |
| SUP12       | 830-860        | 510-570     | ≥ 1079                | ≥ 1226                 | ≥ 9                            | ≥ 20               | 363-429     |
| SUP13       | 830-860        | 510-570     | ≥ 1079                | ≥ 1226                 | ≥ 10                           | ≥ 30               | 363-429     |

**Tabel 4** Nilai faktor koreksi (Sularso, 2008)

| Mesin yang digerakkan      |   | Penggerak  |          |           |   |          |           |
|----------------------------|---|--|----------|-----------|---|----------|-----------|
|                            |   | Momen puntir puncak 200%   |          |           | Momen puntir puncak >200%   |          |           |
|                            |   | Motor arus bolah balik (momen normal, sangkar bajing sinkron), motor arus searah (lilitan shunt) |          |           | Motor arus bolah balik (momen tinggi, fasa tunggal, lilitan seri), motor arus searah (lilitan kompon, lilitan seri), mesin torak kopling tak tetap. |          |           |
|                            |   | Jumlah jam kerja tiap hari   |          |           | Jumlah jam kerja tiap hari  |          |           |
|                            |   | 3-5 jam  | 8-10 jam | 16-24 jam | 3-5 jam   | 8-10 jam | 16-24 jam |
| Variasi beban sangat kecil | Pengaduk zat cair, kipas angin, blower (sampai 7,5 kW) pompa sentrifugal, konveyor tugas ringan                                       | 1  | 1,1      | 1,2       | 1,2   | 1,3      | 1,4       |
| Variasi beban kecil        | Konveyor sabuk (pasir, batu bara), pengaduk, kipas angin (lebih dari 7,5 kW), mesin torak, peluncur, mesin perkakas, mesin percetakan | 1,2  | 1,3      | 1,4       | 1,4   | 1,5      | 1,6       |
| Variasi beban sedang       | Konveyor (ember, sekrup), pompa torak, kompresor, gilingan palu, pengocok, roots-blower, mesin tekstil, mesin kayu                    | 1,3  | 1,4      | 1,5       | 1,6   | 1,7      | 1,8       |
| Variasi beban besar        | Penghancur, gilingan bola atau batang, pengangkat, mesin pabrik karet (rol, kalender)   | 1,5  | 1,6      | 1,7       | 1,8   | 1,9      | 2         |

**Tabel 5** Diagram pemilihan sabuk-V (Mitsuboshi, 2014)

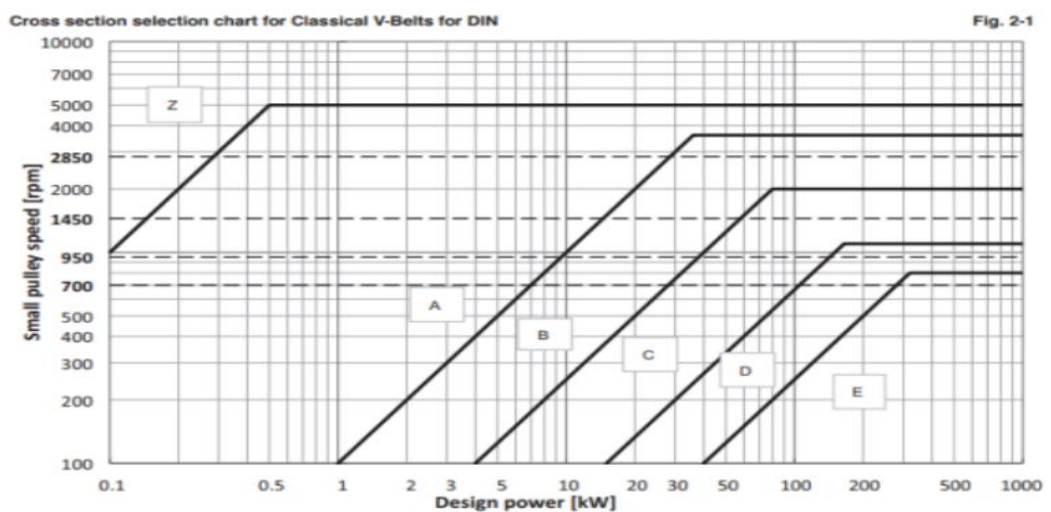

**Tabel 6** Panjang sabuk-V standar (Sularso, 2008)

| Nomor nominal |      | Nomor nominal |      | Nomor nominal |      | Nomor nominal |      |
|---------------|------|---------------|------|---------------|------|---------------|------|
| (inch)        | (mm) | (inch)        | (mm) | (inch)        | (mm) | (inch)        | (mm) |
| 10            | 254  | 45            | 1143 | 80            | 2032 | 115           | 2921 |
| 11            | 279  | 46            | 1168 | 81            | 2057 | 116           | 2946 |
| 12            | 305  | 47            | 1194 | 82            | 2083 | 117           | 2972 |
| 13            | 330  | 48            | 1219 | 83            | 2108 | 118           | 2997 |
| 14            | 356  | 49            | 1245 | 84            | 2134 | 119           | 3023 |
| 15            | 381  | 50            | 1270 | 85            | 2159 | 120           | 3048 |
| 16            | 406  | 51            | 1295 | 86            | 2184 | 121           | 3073 |
| 17            | 432  | 52            | 1321 | 87            | 2210 | 122           | 3099 |
| 18            | 457  | 53            | 1346 | 88            | 2235 | 123           | 3124 |
| 19            | 483  | 54            | 1372 | 89            | 2261 | 124           | 3150 |
| 20            | 508  | 55            | 1397 | 90            | 2286 | 125           | 3175 |
| 21            | 533  | 56            | 1422 | 91            | 2311 | 126           | 3200 |
| 22            | 559  | 57            | 1448 | 92            | 2337 | 127           | 3226 |
| 23            | 584  | 58            | 1473 | 93            | 2362 | 128           | 3251 |
| 24            | 610  | 59            | 1499 | 94            | 2388 | 129           | 3277 |
| 25            | 635  | 60            | 1524 | 95            | 2413 | 130           | 3302 |
| 26            | 660  | 61            | 1549 | 96            | 2438 | 131           | 3327 |
| 27            | 686  | 62            | 1575 | 97            | 2464 | 132           | 3353 |
| 28            | 711  | 63            | 1600 | 98            | 2489 | 133           | 3378 |
| 29            | 737  | 64            | 1626 | 99            | 2515 | 134           | 3404 |
| 30            | 762  | 65            | 1651 | 100           | 2540 | 135           | 3429 |
| 31            | 787  | 66            | 1676 | 101           | 2565 | 136           | 3454 |
| 32            | 813  | 67            | 1702 | 102           | 2591 | 137           | 3480 |
| 33            | 838  | 68            | 1727 | 103           | 2616 | 138           | 3505 |
| 34            | 864  | 69            | 1753 | 104           | 2642 | 139           | 3531 |
| 35            | 889  | 70            | 1778 | 105           | 2667 | 140           | 3556 |
| 36            | 914  | 71            | 1803 | 106           | 2692 | 141           | 3581 |
| 37            | 940  | 72            | 1829 | 107           | 2718 | 142           | 3607 |
| 39            | 965  | 73            | 1854 | 108           | 2743 | 143           | 3632 |
| 39            | 991  | 74            | 1880 | 109           | 2769 | 144           | 3658 |
| 40            | 1016 | 75            | 1905 | 110           | 2794 | 145           | 3683 |
| 41            | 1041 | 76            | 1930 | 111           | 2819 | 146           | 3708 |
| 42            | 1067 | 77            | 1956 | 112           | 2845 | 147           | 3734 |
| 43            | 1092 | 78            | 1981 | 113           | 2870 | 148           | 3759 |
| 44            | 1118 | 79            | 2007 | 114           | 2896 | 149           | 3785 |

**Tabel 7** Faktor layanan (Mott, 2009)

| Jenis beban  | Jenis penggerak    |                           |                                      |
|--|--------------------|---------------------------|--------------------------------------|
|  | Transmisi hidrolik | Motor listrik atau turbin | Motor bakar dengan penggerak mekanis |
| Transmisi halus (pengaduk, kipas angin, lampu, konveyor dengan beban merata)                         | 1.0                | 1.0                       | 1.2                                  |
| Kejutatan sedang (mesin perkakas, kran, konveyor tugas berat, pengaduk makanan dan gerinda)          | 1.2                | 1.3                       | 1.4                                  |
| Kejutatan berat (mesin pres tumbuk, konveyor dengan putaran mampu balik, transmisi mesin giling rol) | 1.4                | 1.5                       | 1.7                                  |

Tabel 8 Horse power rating ((ACA), 2003)

41 HORSEPOWER RATINGS -- SINGLE STRAND ROLLER CHAIN NO. 41 -- 2001

| No. of<br>Teeth | 0.500 inch Pitch |      |      |      |      |      |      |      |      |      |       |       |       |      |      |      |      |      |      |      |      |      |      |      |      |
|-----------------|------------------|------|------|------|------|------|------|------|------|------|-------|-------|-------|------|------|------|------|------|------|------|------|------|------|------|------|
|                 | 10               | 25   | 50   | 100  | 180  | 200  | 300  | 500  | 700  | 900  | 1000  | 1200  | 1400  | 1600 | 1800 | 2100 | 2500 | 3000 | 3500 | 4000 | 5000 | 6000 | 7000 | 8000 | 9000 |
| 11              | 0.03             | 0.07 | 0.15 | 0.28 | 0.50 | 0.55 | 0.81 | 1.33 | 1.84 | 2.34 | 2.25  | 1.71  | 1.36  | 1.11 | 0.93 | 0.74 | 0.57 | 0.43 | 0.34 | 0.28 | 0.20 | 0.15 | 0.12 | 0.10 | 0.00 |
| 12              | 0.03             | 0.08 | 0.16 | 0.31 | 0.54 | 0.60 | 0.89 | 1.45 | 2.00 | 2.55 | 2.57  | 1.95  | 1.55  | 1.27 | 1.06 | 0.84 | 0.65 | 0.49 | 0.39 | 0.32 | 0.23 | 0.17 | 0.14 | 0.11 | 0.00 |
| 13              | 0.04             | 0.09 | 0.17 | 0.34 | 0.59 | 0.65 | 0.96 | 1.57 | 2.17 | 2.76 | 2.89  | 2.20  | 1.75  | 1.43 | 1.20 | 0.95 | 0.73 | 0.56 | 0.44 | 0.36 | 0.26 | 0.20 | 0.16 | 0.00 |      |
| 14              | 0.04             | 0.10 | 0.19 | 0.36 | 0.63 | 0.70 | 1.04 | 1.69 | 2.34 | 2.97 | 3.23  | 2.46  | 1.95  | 1.60 | 1.34 | 1.06 | 0.82 | 0.62 | 0.49 | 0.40 | 0.29 | 0.22 | 0.17 | 0.00 |      |
| 15              | 0.04             | 0.10 | 0.20 | 0.39 | 0.68 | 0.75 | 1.11 | 1.81 | 2.50 | 3.19 | 3.53  | 2.73  | 2.17  | 1.77 | 1.49 | 1.18 | 0.91 | 0.69 | 0.55 | 0.45 | 0.32 | 0.24 | 0.19 | 0.00 |      |
| 16              | 0.05             | 0.11 | 0.21 | 0.41 | 0.73 | 0.80 | 1.18 | 1.93 | 2.67 | 3.40 | 3.76  | 3.01  | 2.39  | 1.95 | 1.64 | 1.30 | 1.00 | 0.76 | 0.60 | 0.49 | 0.35 | 0.27 | 0.00 |      |      |
| 17              | 0.05             | 0.12 | 0.23 | 0.44 | 0.77 | 0.85 | 1.26 | 2.05 | 2.84 | 3.61 | 4.00  | 3.29  | 2.61  | 2.14 | 1.79 | 1.42 | 1.10 | 0.83 | 0.66 | 0.54 | 0.39 | 0.29 | 0.00 |      |      |
| 18              | 0.05             | 0.12 | 0.24 | 0.46 | 0.82 | 0.90 | 1.33 | 2.18 | 3.00 | 3.82 | 4.23  | 3.59  | 2.85  | 2.33 | 1.95 | 1.55 | 1.19 | 0.91 | 0.72 | 0.59 | 0.42 | 0.32 | 0.00 |      |      |
| 19              | 0.05             | 0.13 | 0.25 | 0.49 | 0.86 | 0.95 | 1.41 | 2.30 | 3.17 | 4.04 | 4.47  | 3.89  | 3.09  | 2.53 | 2.12 | 1.68 | 1.29 | 0.98 | 0.78 | 0.64 | 0.46 | 0.09 | 0.00 |      |      |
| 20              | 0.06             | 0.14 | 0.27 | 0.52 | 0.91 | 1.00 | 1.48 | 2.42 | 3.34 | 4.25 | 4.70  | 4.20  | 3.33  | 2.73 | 2.29 | 1.81 | 1.40 | 1.06 | 0.84 | 0.69 | 0.49 | 0.00 |      |      |      |
| 21              | 0.06             | 0.14 | 0.28 | 0.54 | 0.95 | 1.05 | 1.55 | 2.54 | 3.51 | 4.46 | 4.94  | 4.52  | 3.59  | 2.94 | 2.46 | 1.95 | 1.50 | 1.14 | 0.91 | 0.74 | 0.53 | 0.00 |      |      |      |
| 22              | 0.06             | 0.15 | 0.29 | 0.57 | 1.00 | 1.10 | 1.63 | 2.66 | 3.67 | 4.67 | 5.17  | 4.85  | 3.85  | 3.15 | 2.64 | 2.09 | 1.61 | 1.23 | 0.97 | 0.80 | 0.57 | 0.00 |      |      |      |
| 23              | 0.07             | 0.16 | 0.30 | 0.59 | 1.04 | 1.15 | 1.70 | 2.78 | 3.84 | 4.89 | 5.41  | 5.18  | 4.11  | 3.37 | 2.82 | 2.24 | 1.72 | 1.31 | 1.04 | 0.85 | 0.61 | 0.00 |      |      |      |
| 24              | 0.07             | 0.16 | 0.32 | 0.62 | 1.09 | 1.20 | 1.78 | 2.90 | 4.01 | 5.10 | 5.64  | 5.52  | 4.38  | 3.59 | 3.01 | 2.39 | 1.84 | 1.40 | 1.11 | 0.91 | 0.65 | 0.00 |      |      |      |
| 25              | 0.07             | 0.17 | 0.33 | 0.64 | 1.13 | 1.25 | 1.85 | 3.02 | 4.17 | 5.31 | 5.88  | 5.87  | 4.66  | 3.81 | 3.20 | 2.54 | 1.95 | 1.49 | 1.18 | 0.96 | 0.00 |      |      |      |      |
| 26              | 0.07             | 0.18 | 0.34 | 0.67 | 1.18 | 1.30 | 1.92 | 3.14 | 4.34 | 5.52 | 6.11  | 6.23  | 4.94  | 4.05 | 3.39 | 2.69 | 2.07 | 1.58 | 1.25 | 1.02 | 0.00 |      |      |      |      |
| 28              | 0.08             | 0.19 | 0.37 | 0.72 | 1.27 | 1.40 | 2.07 | 3.38 | 4.67 | 5.95 | 6.58  | 6.96  | 5.52  | 4.52 | 3.79 | 3.01 | 2.31 | 1.76 | 1.40 | 1.14 | 0.00 |      |      |      |      |
| 30              | 0.08             | 0.20 | 0.40 | 0.77 | 1.36 | 1.50 | 2.22 | 3.63 | 5.01 | 6.37 | 7.05  | 7.72  | 6.13  | 5.01 | 4.20 | 3.33 | 2.57 | 1.95 | 1.55 | 1.27 | 0.00 |      |      |      |      |
| 32              | 0.09             | 0.22 | 0.42 | 0.82 | 1.45 | 1.60 | 2.37 | 3.87 | 5.34 | 6.80 | 7.52  | 8.50  | 6.75  | 5.52 | 4.63 | 3.67 | 2.83 | 2.15 | 1.71 | 1.40 | 0.00 |      |      |      |      |
| 35              | 0.10             | 0.24 | 0.46 | 0.90 | 1.59 | 1.76 | 2.59 | 4.23 | 5.84 | 7.44 | 8.23  | 9.80  | 7.72  | 6.32 | 5.29 | 4.20 | 3.23 | 2.46 | 1.95 | 0.00 |      |      |      |      |      |
| 40              | 0.11             | 0.27 | 0.53 | 1.03 | 1.81 | 2.01 | 2.96 | 4.83 | 6.68 | 8.50 | 9.40  | 11.20 | 9.43  | 7.72 | 6.47 | 5.13 | 3.95 | 3.01 | 0.00 |      |      |      |      |      |      |
| 45              | 0.13             | 0.31 | 0.60 | 1.16 | 2.04 | 2.26 | 3.33 | 5.44 | 7.51 | 9.56 | 10.58 | 12.60 | 11.25 | 9.21 | 7.72 | 6.13 | 4.72 | 3.59 | 0.00 |      |      |      |      |      |      |

Type A: Manual or Drip Lubrication  
 Type B: Bath or Disc Lubrication  
 Type C: Oil Stream Lubrication

**Tabel 9** Kekuatan tarik material poros (Sularso & Suga, 2008)

| Standar dan macam                         | Lambang | Perlakuan panas | Kekuatan tarik (kg/mm <sup>2</sup> ) | Keterangan  |
|---|---------|-----------------|--------------------------------------|---|
| Baja karbon konstruksi mesin (JIS G 4501) | S30C    | Penormalan      | 48                                   |   |
|   | S35C    | "               | 52                                   |   |
|   | S40C    | "               | 55                                   |   |
|   | S45C    | "               | 58                                   |   |
|   | S50C    | "               | 62                                   |   |
|   | S55C    | "               | 66                                   |   |
| Batang baja yang difinis dingin           | S35C-D  | —               | 53                                   | ditarik dingin, digerinda, dibubut, atau gabungan antara hal-hal tersebut |
|   | S45C-D  | —               | 60                                   |   |
|   | S55C-D  | —               | 72                                   |   |

**Tabel 10** Faktor koreksi momen poros (Khurmi & Gupta, 2005)

| Nature of load                                   | $K_m$      | $K_t$      |
|--|------------|------------|
| <b>1. Stationary shafts</b>                      |            |            |
| (a) Gradually applied load                       | 1.0        | 1.0        |
| (b) Suddenly applied load                        | 1.5 to 2.0 | 1.5 to 2.0 |
| <b>2. Rotating shafts</b>                        |            |            |
| (a) Gradually applied or steady load             | 1.5        | 1.0        |
| (b) Suddenly applied load with minor shocks only | 1.5 to 2.0 | 1.5 to 2.0 |
| (c) Suddenly applied load with heavy shocks      | 2.0 to 3.0 | 1.5 to 3.0 |

**Tabel 11** Umur rancangan bantalan yang dianjurkan (Mott, 2009)

| Aplikasi  | Umur Rancangan, $L_{10}$ , jam |
|---|--------------------------------|
| Peralatan rumah tangga                              | 1000 – 2000                    |
| Mesin pesawat terbang                               | 1000 – 4000                    |
| Otomotif  | 1500 – 5000                    |
| Alat-alat pertanian                                 | 3000 – 6000                    |
| Elevator, kipas angin industri, gigi persneling     | 8000 – 15000                   |
| Motor listrik, blower industri, mesin industri umum | 20000 – 30000                  |
| Pompa dan kompresor                                 | 40000 – 60000                  |
| Peralatan kritis yang beroperasi 24 jam             | 100000 – 200000                |

# LAMPIRAN C

## KATALOG RANTAI SPROCKET DAN PILLOW BLOCK

Tabel 1 Katalog rantai RS 40 (Tsubaki, 2018)

**Standard Roller Chains RS Roller Chain**

## RS40

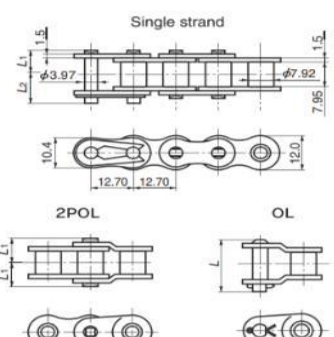

Single strand

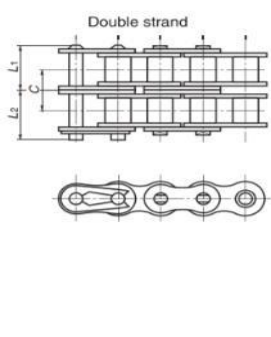

Double strand

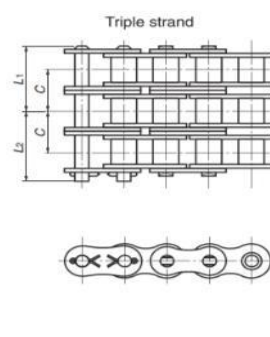

Triple strand

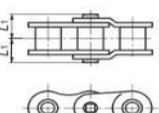

2POL

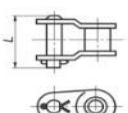

OL

Drawing Scale 1/1.6

| TSUBAKI Chain Number | Number of Strands | Pin Length L <sub>1</sub> +L <sub>2</sub> | Dimensions L <sub>1</sub> | Dimensions L <sub>2</sub> | Offset Pin Length L | Transverse Pitch C | Pin Type | ANSI Standard Min. Tensile Strength kN(kgf) | Tsubaki Minimum Tensile Strength kN(kgf) | Tsubaki Average Tensile Strength kN(kgf) | Maximum Allowable Load kN(kgf) | Approximate Mass kg/m |
|----------------------|-------------------|---|---------------------------|---------------------------|---------------------|--------------------|----------|---|--|--|--------------------------------|-----------------------|
| RS40-1               | 1                 | 18.2                                      | 8.25                      | 9.95                      | 18.2                | 14.4               | Riveting | 15.2 (1550)                                 | 17.7 (1800)                              | 19.1 (1950)                              | 3.63 (370)                     | 0.64                  |
| RS40-2               | 2                 | 32.6                                      | 15.45                     | 17.15                     | 33.5                |                    |          | 30.4 (3100)                                 | 35.3 (3600)                              | 38.2 (3900)                              | 6.18 (630)                     | 1.27                  |
| RS40-3               | 3                 | 46.8                                      | 22.65                     | 24.15                     | 47.9                |                    |          | 45.6 (4650)                                 | 53.0 (5400)                              | 57.4 (5850)                              | 9.12 (930)                     | 1.90                  |
| RS40-4               | 4                 | 61.2                                      | 29.9                      | 31.3                      | 62.3                |                    |          | —   | 70.6 (7200)                              | 76.5 (7800)                              | 12.0 (1220)                    | 2.53                  |
| RS40-5               | 5                 | 75.7                                      | 37.1                      | 38.6                      | 76.8                |                    |          | —   | 88.3 (9000)                              | 95.6 (9750)                              | 14.1 (1440)                    | 3.16                  |
| RS40-6               | 6                 | 90.1                                      | 44.3                      | 45.8                      | 91.2                |                    |          | —   | 106 (10800)                              | 115 (11700)                              | 16.7 (1700)                    | 3.79                  |

Note: 1. Maximum allowable load when using a one-pitch offset link (OL) is 65% of the above. Two pitch offset links (2POL) can be used at 100% of the above values.  
2. Number of links per unit = 240

**■ RS40-1 Maximum Kilowatt Ratings Table (kW Ratings for Single Strand Chain)**

| Small Sprocket No. of Teeth | Small Sprocket Max rpm |      |      |      |      |      |      |      |      |      |      |      |      |      |      |      |      |      |      |      |      |      |      |      |      |  |  |  |
|-----------------------------|------------------------|------|------|------|------|------|------|------|------|------|------|------|------|------|------|------|------|------|------|------|------|------|------|------|------|--|--|--|
|                             | A                      |      |      |      |      |      |      |      |      |      |      |      |      |      | B    |      |      |      |      |      |      |      |      |      |      |  |  |  |
|                             | 10                     | 25   | 50   | 100  | 200  | 300  | 400  | 500  | 700  | 900  | 1000 | 1200 | 1400 | 1600 | 1800 | 2100 | 2400 | 2700 | 3000 | 3500 | 4000 | 5000 | 6000 | 7000 | 8000 |  |  |  |
| 9                           | 0.07                   | 0.15 | 0.28 | 0.52 | 0.97 | 1.40 | 1.81 | 2.21 | 3.00 | 3.75 | 3.75 | 3.75 | 3.75 | 3.07 | 2.58 | 2.04 | 1.67 | 1.40 | 1.20 | 0.95 | 0.78 | 0.56 | 0.42 | 0.34 | 0.27 |  |  |  |
| 10                          | 0.07                   | 0.17 | 0.31 | 0.58 | 1.09 | 1.57 | 2.03 | 2.48 | 3.36 | 4.21 | 4.40 | 4.40 | 4.40 | 3.60 | 3.02 | 2.39 | 1.96 | 1.64 | 1.40 | 1.11 | 0.91 | 0.65 | 0.50 | 0.39 | 0.32 |  |  |  |
| 11                          | 0.08                   | 0.19 | 0.35 | 0.65 | 1.21 | 1.74 | 2.25 | 2.75 | 3.72 | 4.67 | 5.07 | 5.07 | 5.07 | 4.15 | 3.48 | 2.76 | 2.26 | 1.89 | 1.62 | 1.28 | 1.05 | 0.75 | 0.57 | 0.45 | 0.37 |  |  |  |
| 12                          | 0.09                   | 0.20 | 0.38 | 0.71 | 1.32 | 1.91 | 2.47 | 3.02 | 4.09 | 5.13 | 5.64 | 5.67 | 5.67 | 4.73 | 3.97 | 3.15 | 2.58 | 2.16 | 1.84 | 1.46 | 1.20 | 0.86 | 0.65 | 0.52 | 0.42 |  |  |  |
| 13                          | 0.10                   | 0.22 | 0.41 | 0.77 | 1.44 | 2.08 | 2.69 | 3.29 | 4.46 | 5.59 | 6.15 | 6.18 | 6.18 | 5.34 | 4.47 | 3.55 | 2.90 | 2.43 | 2.08 | 1.65 | 1.35 | 0.97 | 0.73 | 0.58 | 0.48 |  |  |  |
| 14                          | 0.11                   | 0.24 | 0.45 | 0.84 | 1.56 | 2.25 | 2.92 | 3.57 | 4.83 | 6.06 | 6.66 | 6.70 | 6.70 | 5.96 | 5.00 | 3.97 | 3.25 | 2.72 | 2.32 | 1.84 | 1.51 | 1.08 | 0.82 | 0.65 | 0.53 |  |  |  |
| 15                          | 0.11                   | 0.26 | 0.48 | 0.90 | 1.69 | 2.43 | 3.14 | 3.84 | 5.20 | 6.52 | 7.17 | 7.21 | 7.21 | 6.61 | 5.54 | 4.40 | 3.60 | 3.02 | 2.58 | 2.04 | 1.67 | 1.20 | 0.91 | 0.72 | 0.59 |  |  |  |
| 16                          | 0.12                   | 0.28 | 0.52 | 0.97 | 1.81 | 2.60 | 3.37 | 4.12 | 5.58 | 7.00 | 7.69 | 7.74 | 7.74 | 7.28 | 6.10 | 4.84 | 3.97 | 3.32 | 2.84 | 2.25 | 1.84 | 1.32 | 1.00 | 0.80 | 0.65 |  |  |  |
| 17                          | 0.13                   | 0.30 | 0.55 | 1.03 | 1.93 | 2.78 | 3.60 | 4.40 | 5.96 | 7.47 | 8.21 | 8.26 | 8.26 | 7.98 | 6.69 | 5.31 | 4.34 | 3.64 | 3.11 | 2.47 | 2.02 | 1.44 | 1.10 | 0.87 | 0.71 |  |  |  |
| 18                          | 0.14                   | 0.32 | 0.59 | 1.10 | 2.05 | 2.96 | 3.83 | 4.68 | 6.34 | 7.94 | 8.73 | 8.79 | 8.79 | 8.69 | 7.28 | 5.78 | 4.73 | 3.97 | 3.39 | 2.69 | 2.20 | 1.57 | 1.20 | 0.95 |      |  |  |  |
| 19                          | 0.15                   | 0.33 | 0.62 | 1.17 | 2.18 | 3.13 | 4.06 | 4.96 | 6.72 | 8.42 | 9.26 | 9.43 | 9.43 | 9.43 | 7.90 | 6.27 | 5.13 | 4.30 | 3.67 | 2.91 | 2.38 | 1.71 | 1.30 | 1.03 |      |  |  |  |
| 20                          | 0.16                   | 0.35 | 0.66 | 1.23 | 2.30 | 3.31 | 4.29 | 5.24 | 7.10 | 8.90 | 9.79 | 10.2 | 10.2 | 10.2 | 8.53 | 6.77 | 5.54 | 4.64 | 3.97 | 3.15 | 2.58 | 1.84 | 1.40 | 1.11 |      |  |  |  |
| 21                          | 0.16                   | 0.37 | 0.70 | 1.30 | 2.42 | 3.49 | 4.52 | 5.53 | 7.48 | 9.38 | 10.3 | 11.0 | 11.0 | 11.0 | 9.18 | 7.28 | 5.96 | 5.00 | 4.27 | 3.39 | 2.77 | 1.98 | 1.51 | 1.20 |      |  |  |  |
| 22                          | 0.17                   | 0.39 | 0.73 | 1.37 | 2.55 | 3.67 | 4.76 | 5.81 | 7.87 | 9.87 | 10.8 | 11.7 | 11.7 | 11.7 | 9.84 | 7.81 | 6.39 | 5.36 | 4.57 | 3.63 | 2.97 | 2.13 | 1.62 | 1.28 |      |  |  |  |
| 23                          | 0.18                   | 0.41 | 0.77 | 1.43 | 2.67 | 3.85 | 4.99 | 6.10 | 8.26 | 10.4 | 11.4 | 12.6 | 12.6 | 12.6 | 10.5 | 8.35 | 6.83 | 5.73 | 4.89 | 3.88 | 3.18 | 2.27 | 1.73 | 1.37 |      |  |  |  |
| 24                          | 0.19                   | 0.43 | 0.80 | 1.50 | 2.80 | 4.03 | 5.22 | 6.39 | 8.65 | 10.8 | 11.9 | 13.4 | 13.4 | 13.4 | 11.2 | 8.90 | 7.28 | 6.10 | 5.21 | 4.14 | 3.39 | 2.42 | 1.84 | 1.46 |      |  |  |  |
| 25                          | 0.20                   | 0.45 | 0.84 | 1.57 | 2.93 | 4.21 | 5.46 | 6.67 | 9.03 | 11.3 | 12.5 | 14.1 | 14.1 | 14.1 | 11.9 | 9.46 | 7.74 | 6.49 | 5.54 | 4.40 | 3.60 | 2.58 | 1.96 |      |      |  |  |  |
| 26                          | 0.21                   | 0.47 | 0.88 | 1.64 | 3.05 | 4.40 | 5.70 | 6.96 | 9.43 | 11.8 | 13.0 | 14.7 | 14.7 | 14.7 | 12.6 | 10.0 | 8.21 | 6.88 | 5.88 | 4.66 | 3.82 | 2.73 | 2.08 |      |      |  |  |  |
| 28                          | 0.22                   | 0.51 | 0.95 | 1.77 | 3.31 | 4.76 | 6.17 | 7.54 | 10.2 | 12.8 | 14.1 | 16.0 | 16.0 | 16.0 | 14.1 | 11.2 | 9.18 | 7.69 | 6.57 | 5.21 | 4.27 | 3.05 | 2.32 |      |      |  |  |  |
| 30                          | 0.24                   | 0.55 | 1.02 | 1.91 | 3.56 | 5.13 | 6.65 | 8.13 | 11.0 | 13.8 | 15.2 | 17.2 | 17.2 | 17.2 | 15.7 | 12.4 | 10.2 | 8.53 | 7.28 | 5.78 | 4.73 | 3.39 | 2.58 |      |      |  |  |  |
| 32                          | 0.26                   | 0.59 | 1.10 | 2.05 | 3.82 | 5.50 | 7.13 | 8.71 | 11.8 | 14.8 | 16.3 | 18.4 | 18.4 | 18.4 | 17.3 | 13.7 | 11.2 | 9.40 | 8.03 | 6.37 | 5.21 | 3.73 |      |      |      |  |  |  |
| 35                          | 0.28                   | 0.65 | 1.21 | 2.26 | 4.21 | 6.06 | 7.85 | 9.60 | 13.0 | 16.3 | 17.9 | 20.3 | 20.3 | 20.3 | 19.8 | 15.7 | 12.8 | 10.8 | 9.18 | 7.28 | 5.96 | 4.27 |      |      |      |  |  |  |
| 40                          | 0.33                   | 0.75 | 1.40 | 2.60 | 4.86 | 7.00 | 9.07 | 11.1 | 15.0 | 18.8 | 20.7 | 24.1 | 24.1 | 24.1 | 24.1 | 19.2 | 15.7 | 13.1 | 11.2 | 8.90 | 7.28 | 5.21 |      |      |      |  |  |  |
| 45                          | 0.37                   | 0.85 | 1.59 | 2.96 | 5.52 | 7.95 | 10.3 | 12.6 | 17.0 | 21.4 | 23.5 | 27.7 | 27.7 | 27.7 | 28.8 | 28.8 | 28.8 | 22.9 | 18.7 | 15.7 | 13.4 | 10.6 | 8.69 |      |      |  |  |  |

Note: 1. kW rating when using a one-pitch offset link (OL) is 80% of the above. Two pitch offset links (2POL) can be used at 100% of the above values.  
2. Please contact a Tsubaki representative prior to use of kW ratings in the colored area of the table.

| Multi-strand factor | Number of chain strands |     | Multi-strand factor |     |
|---------------------|-------------------------|-----|---------------------|-----|
|                     | Double strand           | 1.7 | Quintuple strand    | 3.9 |
|                     | Triple strand           | 2.5 | Sextuple strand     | 4.6 |
|                     | Quadruple strand        | 3.3 | —                   | —   |

| Lubrication method | A                                      |  | Details on Pg. 193 |
|--------------------|--|--|--------------------|
|                    | Manual lubrication or drip lubrication |  |                    |
|                    | Oil bath or slinger disc lubrication   |  |                    |
| C                  | Forced pump lubrication                |  |                    |



Tabel 2 Katalog sprocket RS 40 (Tsubaki, 2018)

Standard Roller Chains  
**RS40 Sprocket**

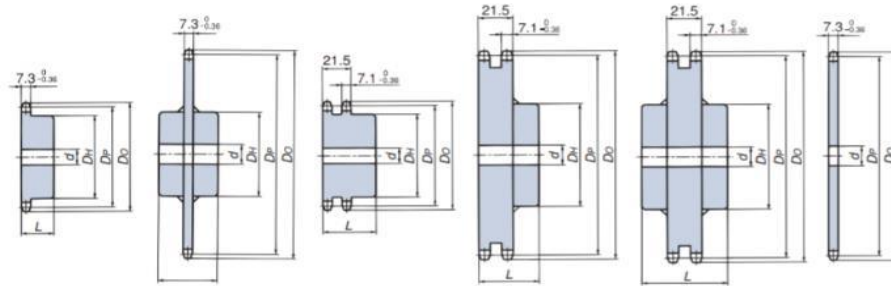

Mechanically machined 1B type    Welded construction 1C type    Mechanically machined 2B type    Welded construction 2C type    Welded construction 2C type

| Number of Teeth | Pitch Circular Diameter (D) | 1B type           |                   |                   |          | 1C type           |                   |                   |          | 2B type           |                   |                   |          | 2C type           |                   |                   |          | 1A type           |                   | Number of Teeth |    |
|-----------------|-----------------------------|-------------------|-------------------|-------------------|----------|-------------------|-------------------|-------------------|----------|-------------------|-------------------|-------------------|----------|-------------------|-------------------|-------------------|----------|-------------------|-------------------|-----------------|----|
|                 |                             | Bore Diameter (d) | Hub Diameter (Dh) | Approx. Mass (kg) | Material | Bore Diameter (d) | Hub Diameter (Dh) | Approx. Mass (kg) | Material | Bore Diameter (d) | Hub Diameter (Dh) | Approx. Mass (kg) | Material | Bore Diameter (d) | Hub Diameter (Dh) | Approx. Mass (kg) | Material | Hub Diameter (Dh) | Approx. Mass (kg) |                 |    |
| 9               | 37.13                       | 43                | 9.5               | 15                | 28       | 22                | 0.10              | ※                 | ※        | ※                 | ※                 | ※                 | ※        | ※                 | ※                 | ※                 | ※        | ※                 | ※                 | 9               |    |
| 10              | 41.10                       | 47                | 9.5               | 16.5              | 32       | 22                | 0.13              | ※                 | ※        | ※                 | ※                 | ※                 | ※        | ※                 | ※                 | ※                 | ※        | ※                 | ※                 | 10              |    |
| 11              | 45.08                       | 51                | 9.5               | 20                | 37       | 22                | 0.17              | ※                 | ※        | ※                 | ※                 | ※                 | ※        | ※                 | ※                 | ※                 | ※        | ※                 | ※                 | 11              |    |
| 12              | 49.07                       | 55                | 9.5               | 22                | 40       | 22                | 0.21              | ※                 | ※        | 9.5               | 18                | 32                | 35       | 0.29              | ※                 | ※                 | 16       | 0.08              | ※                 | 12              |    |
| 13              | 53.07                       | 59                | 9.5               | 20                | 37       | 22                | 0.22              | ※                 | ※        | 12.7              | 20                | 37                | 35       | 0.36              | ※                 | ※                 | 16       | 0.10              | ※                 | 13              |    |
| 14              | 57.07                       | 63                | 9.5               | 24                | 42       | 22                | 0.28              | ※                 | ※        | 12.7              | 24                | 42                | 35       | 0.44              | ※                 | ※                 | 16       | 0.12              | ※                 | 14              |    |
| 15              | 61.08                       | 67                | 9.5               | 28.5              | 46       | 22                | 0.33              | ※                 | ※        | 12.7              | 29                | 46                | 35       | 0.53              | ※                 | ※                 | 16       | 0.14              | ※                 | 15              |    |
| 16              | 65.10                       | 71                | 12.7              | 30                | 50       | 22                | 0.37              | ※                 | ※        | 12.7              | 30                | 50                | 35       | 0.62              | ※                 | ※                 | 16       | 0.16              | ※                 | 16              |    |
| 17              | 69.12                       | 76                | 12.7              | 32                | 54       | 22                | 0.44              | ※                 | ※        | 12.7              | 32                | 54                | 35       | 0.71              | ※                 | ※                 | 16       | 0.18              | ※                 | 17              |    |
| 18              | 73.14                       | 80                | 12.7              | 35                | 57       | 22                | 0.49              | ※                 | ※        | 12.7              | 35                | 57                | 35       | 0.80              | ※                 | ※                 | 16       | 0.21              | ※                 | 18              |    |
| 19              | 77.16                       | 84                | 12.7              | 39.5              | 62       | 22                | 0.57              | ※                 | ※        | 12.7              | 40                | 62                | 35       | 0.93              | ※                 | ※                 | 16       | 0.24              | ※                 | 19              |    |
| 20              | 81.18                       | 88                | 12.7              | 45.5              | 67       | 25                | 0.73              | ※                 | ※        | 12.7              | 46                | 67                | 40       | 1.2               | ※                 | ※                 | 16       | 0.26              | ※                 | 20              |    |
| 21              | 85.21                       | 92                | 12.7              | 45.5              | 71       | 25                | 0.82              | ※                 | ※        | 12.7              | 47                | 71                | 40       | 1.3               | ※                 | ※                 | 16       | 0.29              | ※                 | 21              |    |
| 22              | 89.24                       | 96                | 12.7              | 50                | 75       | 25                | 0.91              | ※                 | ※        | 12.7              | 50                | 75                | 40       | 1.5               | ※                 | ※                 | 16       | 0.32              | ※                 | 22              |    |
| 23              | 93.27                       | 100               | 12.7              | 50                | 77       | 25                | 0.98              | ※                 | ※        | 12.7              | 50                | 77                | 40       | 1.6               | ※                 | ※                 | 16       | 0.35              | ※                 | 23              |    |
| 24              | 97.30                       | 104               | 12.7              | 42                | 63       | 25                | 0.80              | ※                 | ※        | 12.7              | 55                | 83                | 40       | 1.8               | ※                 | ※                 | 16       | 0.39              | ※                 | 24              |    |
| 25              | 101.33                      | 108               | 12.7              | 42                | 63       | 25                | 0.83              | ※                 | ※        | 12.7              | 59                | 87                | 40       | 2.0               | ※                 | ※                 | 16       | 0.42              | ※                 | 25              |    |
| 26              | 105.36                      | 112               | 12.7              | 42                | 63       | 25                | 0.87              | ※                 | ※        | 12.7              | 62                | 91                | 40       | 2.2               | ※                 | ※                 | 16       | 0.46              | ※                 | 26              |    |
| 27              | 109.40                      | 116               | 12.7              | 42                | 63       | 25                | 0.91              | ※                 | ※        | 12.7              | 65                | 95                | 40       | 2.4               | ※                 | ※                 | 16       | 0.50              | ※                 | 27              |    |
| 28              | 113.43                      | 120               | 12.7              | 42                | 63       | 25                | 0.95              | ※                 | ※        | 12.7              | 67                | 99                | 40       | 2.6               | ※                 | ※                 | 16       | 0.53              | ※                 | 28              |    |
| 30              | 121.50                      | 128               | 12.7              | 42                | 63       | 25                | 1.0               | ※                 | ※        | 12.7              | 73                | 106               | 40       | 3.0               | ※                 | ※                 | 16       | 0.62              | ※                 | 30              |    |
| 32              | 129.57                      | 137               | 16                | 45                | 68       | 28                | 1.3               | ※                 | ※        | 12.7              | 78                | 115               | 50       | 4.2               | ※                 | ※                 | 16       | 0.71              | ※                 | 32              |    |
| 34              | 137.64                      | 145               | 16                | 45                | 68       | 28                | 1.4               | ※                 | ※        | 12.7              | 84                | 124               | 50       | 4.9               | ※                 | ※                 | 16       | 0.80              | ※                 | 34              |    |
| 35              | 141.68                      | 149               | 16                | 45                | 68       | 28                | 1.4               | ※                 | ※        | 16                | 63                | 93                | 50       | 3.9               | ※                 | 16                | 63       | 93                | 70                | 4.9             | 35 |
| 36              | 145.72                      | 153               | 16                | 45                | 68       | 28                | 1.5               | ※                 | ※        | 16                | 63                | 93                | 50       | 4.0               | ※                 | 16                | 63       | 93                | 70                | 5.1             | 36 |
| 38              | 153.79                      | 161               | 16                | 45                | 68       | 28                | 1.6               | ※                 | ※        | 16                | 63                | 93                | 50       | 4.3               | ※                 | 16                | 63       | 93                | 70                | 5.4             | 38 |
| 40              | 161.87                      | 169               | 16                | 45                | 68       | 28                | 1.7               | ※                 | ※        | 16                | 63                | 93                | 50       | 4.6               | ※                 | 16                | 63       | 93                | 70                | 5.7             | 40 |
| 42              | 169.94                      | 177               | 18                | 48                | 73       | 32                | 2.0               | ※                 | ※        | 16                | 63                | 93                | 50       | 5.0               | ※                 | 16                | 63       | 93                | 70                | 6.0             | 42 |
| 45              | 182.06                      | 189               | 18                | 48                | 73       | 32                | 2.2               | ※                 | ※        | 18                | 63                | 93                | 50       | 5.5               | ※                 | 18                | 63       | 93                | 70                | 6.5             | 45 |
| 48              | 194.18                      | 201               | 18                | 48                | 73       | 32                | 2.4               | ※                 | ※        | 18                | 63                | 93                | 50       | 6.0               | ※                 | 18                | 63       | 93                | 70                | 7.1             | 48 |
| 50              | 202.26                      | 209               | 18                | 48                | 73       | 32                | 2.5               | ※                 | ※        | 18                | 63                | 93                | 50       | 6.5               | ※                 | 18                | 63       | 93                | 70                | 7.5             | 50 |
| 54              | 218.42                      | 226               | 18                | 48                | 73       | 32                | 2.8               | ※                 | ※        | 18                | 63                | 93                | 50       | 7.3               | ※                 | 18                | 63       | 93                | 70                | 8.4             | 54 |
| 60              | 242.66                      | 250               | 18                | 48                | 73       | 32                | 3.3               | ※                 | ※        | 18                | 63                | 93                | 50       | 8.8               | ※                 | 18                | 63       | 93                | 70                | 9.8             | 60 |
| 65              | 262.87                      | 270               | 23                | 55                | 83       | 32                | 4.0               | ※                 | ※        | 23                | 55                | 83                | 50       | 4.7               | ※                 | 23                | 55       | 83                | 50                | 4.7             | 65 |
| 70              | 283.07                      | 290               | 23                | 55                | 83       | 32                | 4.5               | ※                 | ※        | 23                | 55                | 83                | 50       | 5.2               | ※                 | 23                | 55       | 83                | 50                | 5.2             | 70 |
| 75              | 303.28                      | 311               | 23                | 55                | 83       | 32                | 5.0               | ※                 | ※        | 23                | 55                | 83                | 50       | 5.7               | ※                 | 23                | 55       | 83                | 50                | 5.7             | 75 |

Note: 1. Maximum bore diameter is the typical range. Determine bore diameter and key bearing pressure based on general mechanical design.  
 2. Models in shaded areas have hardened teeth.  
 3. The outer diameters above are given for the 1B type. Diameters vary slightly for all other types.  
 4. 1B-type sprockets marked with an \* have an outer groove around the hub. Groove outer diameter is 21 for 9T, 25 for 10T, 30 for 11T and 32 for 12T.  
 5. For single-strand sprockets without hardened teeth, the Strong Series of sprocket with hardened teeth can be made-to-order.  
 6. Welded specification: machine-structural carbon steel (teeth) and structural rolled steel (hub)

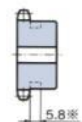
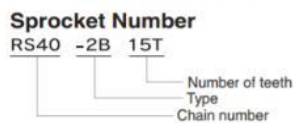

Tabel 3 Katalog *pillow block bearing* UCP (Nachi, 2008)

**PILLOW BLOCKS**

**UCP 200 type**

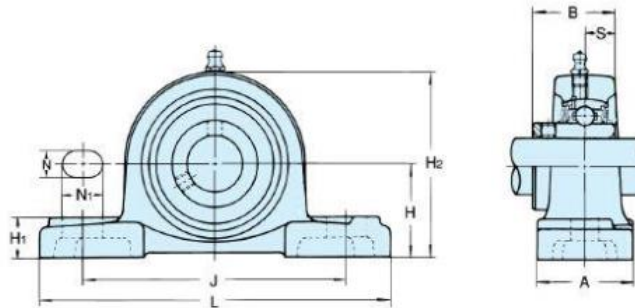

| Shaft Diam. mm | Unit No. | Dimensions mm |     |     |    |    |                |                |                |      |      | Bolt Size mm | Bearing |                            | Housing No. | Weight kg |      |
|----------------|----------|---------------|-----|-----|----|----|----------------|----------------|----------------|------|------|--------------|---------|----------------------------|-------------|-----------|------|
|                |          | H             | L   | J   | A  | N  | N <sub>1</sub> | H <sub>1</sub> | H <sub>2</sub> | B    | S    |              | No.     | Basic Load Rating kN<br>Cr |             |           |      |
| 12             | UCP 201  | 30.2          | 127 | 95  | 38 | 13 | 19             | 15             | 62             | 31   | 12.7 | M10          | UC 201  | 12.8                       | 6.6         | P 203     | 0.65 |
| 15             | UCP 202  | 30.2          | 127 | 95  | 38 | 13 | 19             | 15             | 62             | 31   | 12.7 | M10          | UC 202  | 12.8                       | 6.6         | P 203     | 0.63 |
| 17             | UCP 203  | 30.2          | 127 | 95  | 38 | 13 | 19             | 15             | 62             | 31   | 12.7 | M10          | UC 203  | 12.8                       | 6.6         | P 203     | 0.62 |
| 20             | UCP 204  | 33.3          | 127 | 95  | 38 | 13 | 19             | 15             | 65             | 31   | 12.7 | M10          | UC 204  | 12.8                       | 6.6         | P 204     | 0.65 |
| 25             | UCP 205  | 36.5          | 140 | 105 | 38 | 13 | 16             | 16             | 70             | 34.1 | 14.3 | M10          | UC 205  | 14                         | 7.9         | P 205     | 0.79 |
| 30             | UCP 206  | 42.9          | 165 | 121 | 48 | 17 | 21             | 18             | 83             | 38.1 | 15.9 | M14          | UC 206  | 19.6                       | 11.3        | P 206     | 1.26 |
| 35             | UCP 207  | 47.6          | 167 | 127 | 48 | 17 | 21             | 19             | 94             | 42.9 | 17.5 | M14          | UC 207  | 25.9                       | 15.4        | P 207     | 1.59 |
| 40             | UCP 208  | 49.2          | 184 | 137 | 54 | 17 | 25             | 19             | 100            | 49.2 | 19   | M14          | UC 208  | 29.3                       | 17.9        | P 208     | 1.92 |
| 45             | UCP 209  | 54            | 190 | 146 | 54 | 17 | 22             | 20             | 108            | 49.2 | 19   | M14          | UC 209  | 33                         | 20.5        | P 209     | 2.19 |
| 50             | UCP 210  | 57.2          | 206 | 159 | 60 | 20 | 25             | 22             | 114            | 51.6 | 19   | M16          | UC 210  | 35.5                       | 23.2        | P 210     | 2.59 |
| 55             | UCP 211  | 63.5          | 219 | 171 | 60 | 20 | 25             | 22             | 126            | 55.6 | 22.2 | M16          | UC 211  | 43                         | 29.4        | P 211     | 3.3  |
| 60             | UCP 212  | 69.8          | 241 | 184 | 70 | 20 | 25             | 25             | 138            | 65.1 | 25.4 | M16          | UC 212  | 52.5                       | 36.1        | P 212     | 4.7  |
| 65             | UCP 213  | 76.2          | 265 | 203 | 70 | 25 | 29             | 27             | 150            | 65.1 | 25.4 | M20          | UC 213  | 57.5                       | 40          | P 213     | 5.6  |
| 70             | UCP 214  | 79.4          | 266 | 210 | 72 | 25 | 31             | 27             | 156            | 74.6 | 30.2 | M20          | UC 214  | 62                         | 44          | P 214     | 7.3  |
| 75             | UCP 215  | 82.6          | 275 | 217 | 74 | 25 | 31             | 28             | 163            | 77.8 | 33.3 | M20          | UC 215  | 66                         | 48.2        | P 215     | 7.9  |
| 80             | UCP 216  | 88.9          | 292 | 232 | 78 | 25 | 31             | 30             | 175            | 82.6 | 33.3 | M20          | UC 216  | 72.5                       | 53          | P 216     | 10.0 |
| 85             | UCP 217  | 95.2          | 310 | 247 | 83 | 25 | 31             | 32             | 187            | 85.7 | 34.1 | M20          | UC 217  | 83.5                       | 61.8        | P 217     | 12.2 |
| 90             | UCP 218  | 101.6         | 327 | 262 | 88 | 27 | 33             | 34             | 200            | 96   | 39.7 | M22          | UC 218  | 95.5                       | 71.4        | P 218     | 14.7 |

**LAMPIRAN D**  
**TABEL DATA PEMESINAN**

**Tabel 1** Putaran mesin gurdi

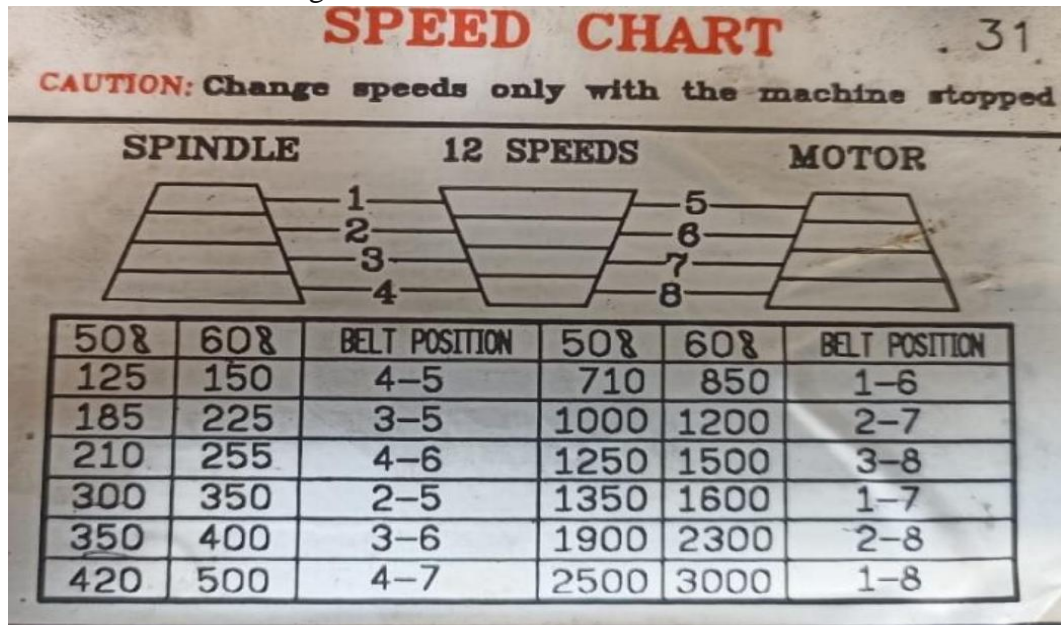

**Tabel 2** Kecepatan potong proses bubut rata dan proses bubut ulir untuk pahat HSS (Widarto, 2008)



| MATERIAL                  | STRAIGHT TURNING SPEED |                   | THREADING SPEED |                   |
|---------------------------|------------------------|-------------------|-----------------|-------------------|
|                           | FEET PER MINUTE        | METERS PER MINUTE | FEET PER MINUTE | METERS PER MINUTE |
| LOW-CARBON STEEL          | 80-100                 | 24.4-30.5         | 35-40           | 10.7-12.2         |
| MEDIUM-CARBON STEEL       | 60-80                  | 18.3-24.4         | 25-30           | 7.6-9.1           |
| HIGH-CARBON STEEL         | 35-40                  | 10.7-12.2         | 15-20           | 4.6-6.1           |
| STAINLESS STEEL           | 40-50                  | 12.2-15.2         | 15-20           | 4.6-6.1           |
| ALUMINUM AND ITS ALLOYS   | 200-300                | 61.0-91.4         | 50-80           | 15.2-18.3         |
| ORDINARY BRASS AND BRONZE | 100-200                | 30.5-61.0         | 40-50           | 12.2-15.2         |
| HIGH-TENSILE BRONZE       | 40-60                  | 12.2-18.3         | 20-25           | 6.1-7.6           |
| CAST IRON                 | 50-80                  | 15.2-24.4         | 20-25           | 6.1-7.6           |
| COPPER                    | 60-80                  | 18.3-24.4         | 20-25           | 6.1-7.6           |

NOTE: Speeds for carbide-tipped bits can be 2 to 3 times the speed recommended for high-speed steel

**Tabel 3** Putaran mesin bubut

|   | 1   | 2   | 3    |
|---|-----|-----|------|
| A | 60  | 220 | 860  |
| B | 92  | 360 | 1400 |
| C | 140 | 530 | 2000 |

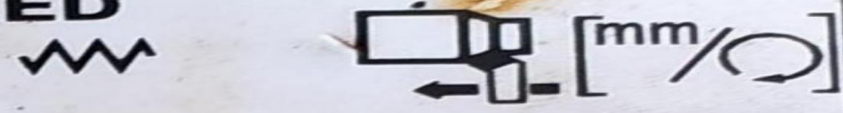
**Tabel 4** Gerak makan mesin bubut

| LONGITUDINAL FEED  |       |       |       |       |
|--|-------|-------|-------|-------|
|  |       |       |       |       |
|   | M     |       |       |       |
|  | D     | E     | F     | G     |
| 1  | 0.044 | 0.088 | 0.176 | 0.352 |
| 2  | 0.050 | 0.099 | 0.198 | 0.396 |
| 3  | 0.052 | 0.105 | 0.210 | 0.420 |
| 4  | 0.055 | 0.110 | 0.220 | 0.440 |
| 5  | 0.060 | 0.121 | 0.242 | 0.484 |
| 6  | 0.063 | 0.127 | 0.254 | 0.508 |
| 7  | 0.066 | 0.132 | 0.264 | 0.528 |
| 8  | 0.072 | 0.144 | 0.287 | 0.574 |
| 9  | 0.075 | 0.149 | 0.298 | 0.596 |
| 10   | 0.077 | 0.154 | 0.308 | 0.616 |
| 11   | 0.083 | 0.166 | 0.331 | 0.662 |

**Tabel 5** Data material, kecepatan potong, sudut mata bor HSS dan cairan pendingin proses gurdi (Widarto, Sutopo dan Paryanto, 2008)

| MATERIAL                              | CUTTING SPEEDS 1. |               | POINT ANGLE   | LIP CLEARANCE | COOLANTS                                    |
|---------------------------------------|-------------------|---------------|---------------|---------------|---|
|                                       | (METERS/MINUTE)   | (FEET/MINUTE) |               |               |   |
|                                       | MPM               | FPM           |               |               |   |
| Aluminum And Alloys                   | 61.00 - 91.50     | 200 - 300     | 90 - 130 deg  | 12 - 15 deg   | Kerosene/Kerosene & Lard Oil/ Soluble Oil   |
| Armor Plate                           | 12.20 - 18.25     | 40 - 50       | 135 - 140 deg | 6 - 9 deg     | Light Machine Oil                           |
| Brass                                 | 61.00 - 91.50     | 200 - 300     | 118 - 118 deg | 12 - 15 deg   | Dry/ Soluble Oil/Kerosene/Lard Oil          |
| Bronze                                | 61.00 - 91.50     | 200 - 300     | 110 - 118 deg | 12 - 15 deg   | Dry/ Soluble Oil/Mineral Oil/Lard Oil       |
| Bronze, High Tensile                  | 21.35 - 45.75     | 70 - 150      | 100 - 110 deg | 12 - 15 deg   | Dry/ Soluble Oil/Mineral Oil/Lard Oil       |
| Cast Iron, Soft                       | 30.50 - 45.75     | 100 - 150     | 90 - 100 deg  | 12 - 15 deg   | Air Jet Dry/ Soluble Oil                    |
| Cast Iron, Medium                     | 21.35 - 30.50     | 70 - 100      | 100 - 110 deg | 12 - 15 deg   | Air Jet Dry/ Soluble Oil                    |
| Cast Iron, Hard                       | 21.35 - 30.50     | 70 - 100      | 100 - 118 deg | 8 - 12 deg    | Air Jet Dry/ Soluble Oil                    |
| Cast Iron, Chilled                    | 9.15 - 12.20      | 30 - 40       | 118 - 135 deg | 5 - 9 deg     | Air Jet Dry/ Soluble Oil                    |
| Copper                                | 61.00 - 91.50     | 200 - 300     | 100 - 118 deg | 12 - 15 deg   | Air Jet Dry/ Soluble Oil                    |
| Copper Graphite Alloy (Carbon Drills) | 18.30 - 21.35     | 60 - 70       | **_**         | **_**         | Soluble Oil/Dry/Mineral Oil/Kerosene        |
| Glass (Carbon Drills)                 | 6.10 - 9.15       | 20 - 30       | **_**         | **_**         | Soluble Oil/Dry/Mineral Oil/Kerosene        |
| Iron, Malleable                       | 15.25 - 27.45     | 50 - 90       | 90 - 100 deg  | 12 - 15 deg   | Light Machine Oil                           |
| Magnesium And Alloys                  | 76.25 - 122.0     | 250 - 400     | 70 - 118 deg  | 12 - 15 deg   | Soluble Oil                                 |
| Monel Nickel                          | 4.15 - 15.28      | 30 - 50       | 118 - 125 deg | 10 - 12 deg   | Compressed Air/Mineral Oil                  |
| Nickel Alloys                         | 12.20 - 18.30     | 40 - 60       | 135 - 140 deg | 5 - 7 deg     | Lard Oil/Soluble Oil                        |
| Plastic, Hot Set                      | 30.50 - 91.50     | 100 - 300     | 60 - 90 deg   | 10 - 12 deg   | Lard Oil/Soluble Oil                        |
| Plastic, Cold Set                     | 30.50 - 91.50     | 100 - 300     | 118 - 135 deg | 12 - 20 deg   | Soap Solution                               |
| Steel, Low Carbon, 0.2-0.3ct          | 24.40 - 33.55     | 80 - 110      | 110 - 118 deg | 7 - 9 deg     | Soap Solution                               |
| Steel, Medium Carbon 0.4-0.5c         | 21.35 - 24.40     | 70 - 80       | 118 - 125 deg | 7 - 9 deg     | Soluble Oil/Mineral Oil/Sulfur Oil/Lard Oil |
| Steel (High Carbon 1.2c)              | 15.25 - 18.30     | 50 - 60       | 118 - 145 deg | 7 - 9 deg     | Soluble Oil/Mineral Oil/Sulfur Oil/Lard Oil |
| Steel, Forged                         | 15.25 - 18.30     | 50 - 60       | 118 - 145 deg | 7 - 12 deg    | Soluble Oil/Mineral Oil/Sulfur Oil/Lard Oil |
| Steel, Alloy                          | 15.25 - 21.35     | 50 - 70       | 118 - 125 deg | 10 - 12 deg   | Mineral Lard Oil                            |
| Steel, Alloy 300 To 400 Brinell       | 6.10 - 9.15       | 20 - 30       | 130 - 140 deg | 7 - 10 deg    | Soluble Oil                                 |
| Steel, Stainless, Free Machining      | 9.15 - 24.40      | 30 - 80       | 110 - 118 deg | 8 - 12 deg    | Soluble Oil                                 |
| Steel, Stainless, Hard                | 4.57 - 15.25      | 15 - 50       | 118 - 135 deg | 6 - 8 deg     | Soluble Oil                                 |
| Steel, Manganese                      | 3.66 - 4.57       | 12 - 15       | 140 - 150 deg | 7 - 10 deg    | Soluble Oil                                 |
| Stone (Carbide Drills)                | 7.63 - 9.15       | 25 - 30       | **_**         | **_**         | Water Solution                              |
| Wood                                  | 91.50 - 122.2     | 300 - 400     | 60 - 70 deg   | 10 - 15 deg   | Dry   |

**LAMPIRAN E**  
**BILL OF MATERIALS**

**Tabel 1** *Bill of materials*

| No.           | Nama Komponen           | Spesifikasi                     | Satuan | Harga Satuan | Jumlah Pemakaian |        | Harga Komponen     |
|---------------|-------------------------|---------------------------------|--------|--------------|------------------|--------|--------------------|
|               |                         |                                 |        |              | Panjang (mm)     | Jumlah |                    |
| <b>A</b>      | <b>Rangka utama</b>     |                                 |        |              |                  |        |                    |
| 1.            | Besi siku               | 40×40×4 mm                      | batang | Rp. 125.000  | 8.400            | 2      | Rp. 250.000        |
| 2.            | Besi UNP                | 50×38×5 mm                      | batang | Rp. 270.000  | 4.400            | 1      | Rp. 270.000        |
| <b>Jumlah</b> |                         |                                 |        |              |                  |        | <b>Rp. 520.000</b> |
| <b>B.</b>     | <b>Sistem pengumpan</b> |                                 |        |              |                  |        |                    |
| 1.            | Bantalan                | UCP 205                         | buah   | Rp. 45.000   | -                | 4      | Rp. 180.000        |
| 2.            | Poros pengumpan 1       | Baja S45C                       | buah   | Rp. 48.000   | 240              | 1      | Rp. 48.000         |
| 3.            | Poros pengumpan 2       | Baja S45C                       | buah   | Rp. 102.000  | 510              | 1      | Rp. 102.000        |
| 4.            | Plate pengumpan         | Plate strip 50×5 mm             | buah   | Rp. 125.000  | 3440             | 1      | Rp. 140.000        |
| 5.            | Poros rell              | Baja S45C                       | buah   | Rp. 72.000   | 360              | 1      | Rp. 360.000        |
| 6.            | Roda pengumpan          | Roda pagar AS                   | buah   | Rp. 30.000   | -                | 6      | Rp. 180.000        |
| 7.            | Dudukan roda pengumpan  | Plate 270×205×3 mm              | buah   | Rp. 85.000   | -                | 1      | Rp. 85.000         |
| 8.            | Lengan poros pengumpan  | Baja S45C                       | buah   | Rp. 35.000   | 60               | 1      | Rp. 35.000         |
| 9.            | Pemberat pengumpan      | Baja S45C                       | buah   | Rp. 30.000   | 55               | 1      | Rp. 30.000         |
| 10.           | Spring                  | Spring tarik 1 mm panjang 60 mm | buah   | Rp. 21.000   | -                | 3      | Rp. 63.000         |

**Tabel 1** *Bill of materials* (lanjutan)

| No.                       | Nama Komponen          | Spesifikasi                       | Satuan | Harga Satuan | Jumlah Pemakaian |        | Harga Komponen       |
|---------------------------|------------------------|-----------------------------------|--------|--------------|------------------|--------|----------------------|
|                           |                        |                                   |        |              | Panjang (mm)     | Jumlah |                      |
| 11.                       | Pengait pengumpan      | Plate strip 80×10 mm              | buah   | Rp. 34.000   | 80               | 5      | Rp. 170.000          |
| <b>Total</b>              |                        |                                   |        |              |                  |        | <b>Rp. 1.393.000</b> |
| <b>C. Sistem penekuk</b>  |                        |                                   |        |              |                  |        |                      |
| 1.                        | Bantalan               | UCP 205                           | buah   | Rp. 45.000   | -                | 2      | Rp. 90.000           |
| 2.                        | Poros                  | Baja S45C                         | buah   | Rp. 102.000  | 510              | 1      | Rp. 102.000          |
| 3.                        | Dudukan penekuk        | Plate strip 30×10 mm              | buah   | Rp. 34.000   | 20               | 1      | Rp. 34.000           |
| 4.                        | Penekuk                | Plate strip 100×10 mm             | buah   | Rp. 68.000   | 200              | 2      | Rp. 136.000          |
| 5.                        | Pengait penekuk        | Plate strip 80×10 mm              | buah   | Rp. 34.000   | 80               | 5      | Rp. 170.000          |
| 6.                        | <i>Flywheel</i>        | Plate strip 600×10 mm             | buah   | Rp. 225.000  | 600              | 1      | Rp. 225.000          |
| 7.                        | <i>Spring</i>          | Spring tarik 1mm panjang 120 mm   | buah   | Rp. 28.000   | -                | 1      | Rp. 28.000           |
| <b>Total</b>              |                        |                                   |        |              |                  |        | <b>Rp. 785.000</b>   |
| <b>D. Sistem pemotong</b> |                        |                                   |        |              |                  |        |                      |
| 1.                        | Pengait pemotong       | Plate strip 80×10 mm              | buah   | Rp. 42.000   | 120              | 1      | Rp. 42.000           |
| 2.                        | Gunting pemotong begel | Besi baja pegas daun 100×30×25 mm | buah   | Rp. 220.000  | 100              | 2      | Rp. 440.000          |
| 3.                        | Penahan gunting        | Hollow 30×30×3 mm                 | buah   | Rp. 42.000   | 430              | 1      | Rp. 42.000           |
| 4.                        | <i>Spring</i>          | Spring tarik 1 mm panjang 50 mm   | Buah   | Rp. 18.000   | -                | 1      | Rp. 18.000           |
| <b>Total</b>              |                        |                                   |        |              |                  |        | <b>Rp. 542.000</b>   |

**Tabel 1** *Bill of materials* (lanjutan)

| No.                           | Nama Komponen              | Spesifikasi     | Satuan | Harga Satuan | Jumlah Pemakaian |        | Harga Komponen |
|-------------------------------|----------------------------|-----------------|--------|--------------|------------------|--------|----------------|
|                               |                            |                 |        |              | Panjang (mm)     | Jumlah |                |
| <b>E.</b>                     | <b>Komponen lain</b>       |                 |        |              |                  |        |                |
| 1.                            | Motor listrk AC            | 1 hp            | buah   | Rp. 950.000  | -                | 1      | Rp. 950.000    |
| 2.                            | <i>Pulley</i> penggerak    | 2 inch          | buah   | Rp. 25.000   | -                | 1      | Rp. 25.000     |
| 3.                            | <i>Pulley</i> digerakkan   | 16 inch         | Buah   | Rp. 235.000  | -                | 1      | Rp. 235.000    |
| 4.                            | Sabuk-V                    | Tipe A          | buah   | Rp. 76.000   | 2007             | 1      | Rp. 76.000     |
| 5.                            | <i>Gearbox</i>             | WPA 50, 1:10    | buah   | Rp. 560.000  | -                | 1      | Rp. 560.000    |
| 6.                            | <i>Sprocket</i> penggerak  | RS40, 12T       | buah   | Rp. 30.000   | -                | 1      | Rp. 30.000     |
| 7.                            | <i>Sprocket</i> digerakkan | RS40, 48T       | buah   | Rp. 225.000  | -                | 1      | Rp. 225.000    |
| 8.                            | Rantai                     | RS40            | buah   | Rp. 115.000  | 914,4            | 1      | Rp. 115.000    |
| 9.                            | <i>Electroda</i>           | RD460Ø3×300 mm  | dus    | Rp. 70.000   | -                | 2      | Rp. 140.000    |
| 10.                           | Mur dan baut               | M10             | buah   | Rp. 1.500    | -                | 16     | Rp. 24.000     |
| 11.                           | Mur dan baut               | M6              | buah   | Rp. 1.000    | -                | 8      | Rp. 8.000      |
| 12.                           | Cat                        | Avian           | kaleng | Rp. 35.000   | -                | 2      | Rp. 70.000     |
| 13.                           | Tiner                      | Tipe B          | botol  | Rp. 15.000   | -                | 1      | Rp. 15.000     |
| 13.                           | Tombol on-off              | -               | buah   | Rp. 12.000   | -                | 1      | Rp. 12.000     |
| 14.                           | Kuas                       | Ukuran 0,5 inch | buah   | Rp. 18.000   | -                | 1      | Rp. 18.000     |
| <b>Total</b>                  |                            |                 |        |              |                  |        | Rp. 2.503.000  |
| <b>Total seluruh komponen</b> |                            |                 |        |              |                  |        | Rp. 5.743.000  |



**LAMPIRAN F GAMBAR KERJA**

4

3

2

| No. | Perubahan | Tanggal | Nama | No. | Perubahan | Tanggal | Nama |
|-----|-----------|---------|------|-----|-----------|---------|------|
| △   |           |         |      | △   |           |         |      |

F

F

E

E

D

D

C

C

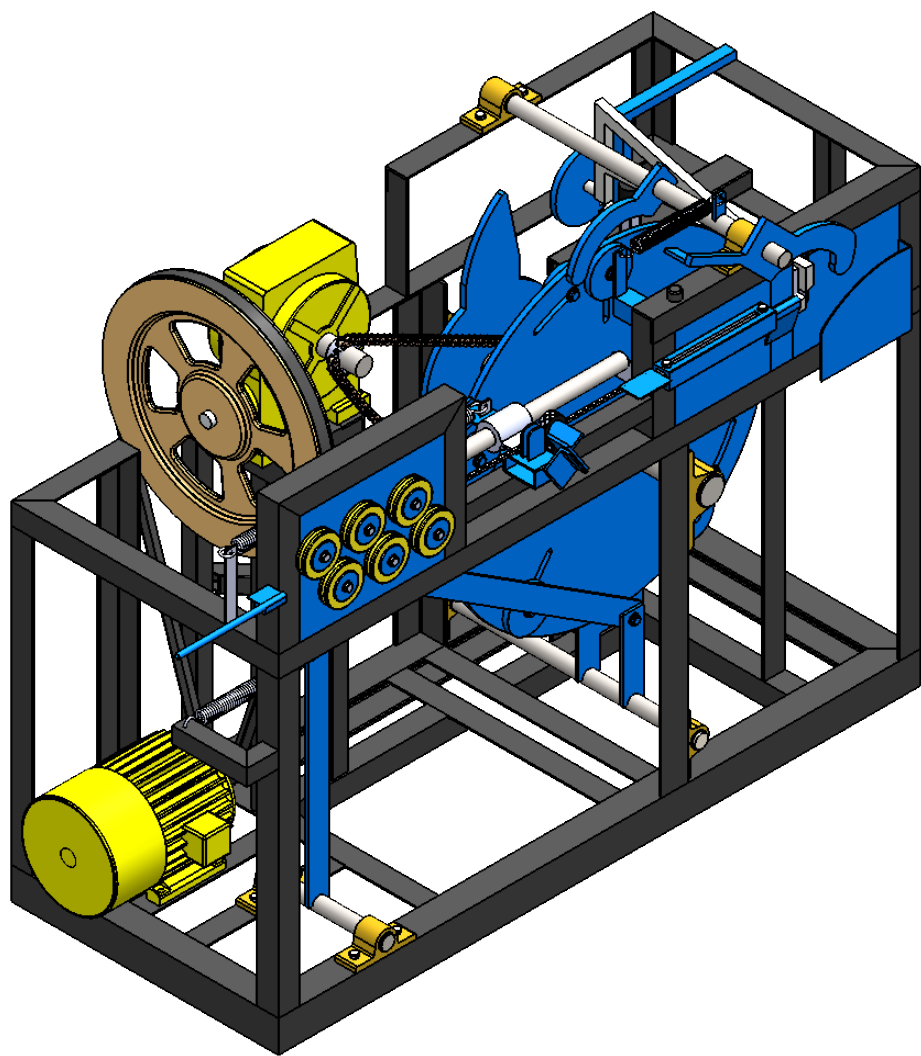

B

B

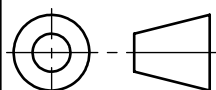
| 1   | MESIN PEMBUAT BEGEL |      |      |      |      | -     | -                  | -            | -         |   |
|-----|---------------------|------|------|------|------|-------|--------------------|--------------|-----------|---|
| JML | NAMA BAGIAN         |      |      |      |      | BAHAN | UKURAN JADI        | UKURAN KASAR | NO. ID    | KETERANGAN  |
| >   | 0                   | 6    | 30   | 120  | 400  | 1000  | Pengerjaan Lanjut: |              | NO. ORDER | PROYEKSI  |
| <   | 6                   | 30   | 120  | 400  | 1000 | 2000  |                    |              |           |  |
| Tol | +0.1                | +0.2 | +0.3 | +0.5 | +0.8 | +1.2  |                    |              |           |   |

A

A

Nama:

# MESIN PEMBUAT BEGEL

No. Assy:

Skala

1:10

|           |         |        |
|-----------|---------|--------|
| DIGAMBAR  | 10-4-23 | DITO   |
| DIPERIKSA |         | PUJONO |
| DISAHKAN  |         | PUJONO |



**Politeknik Negeri Cilacap, Jurusan Teknik Mesin**  
 Jl. Dr. Soetomo, No. 01, Sidakaya, Cilacap, 53212  
 Telp: 0282-533329, E-mail: tmpnc@politeknikcilacap.ac.id

FORMAT  
A4

SATUAN  
mm

NO. GAMBAR:  
**NO. 01/TM**

4



3

2

PENGANTI DARI:

DIGANTI DENGAN

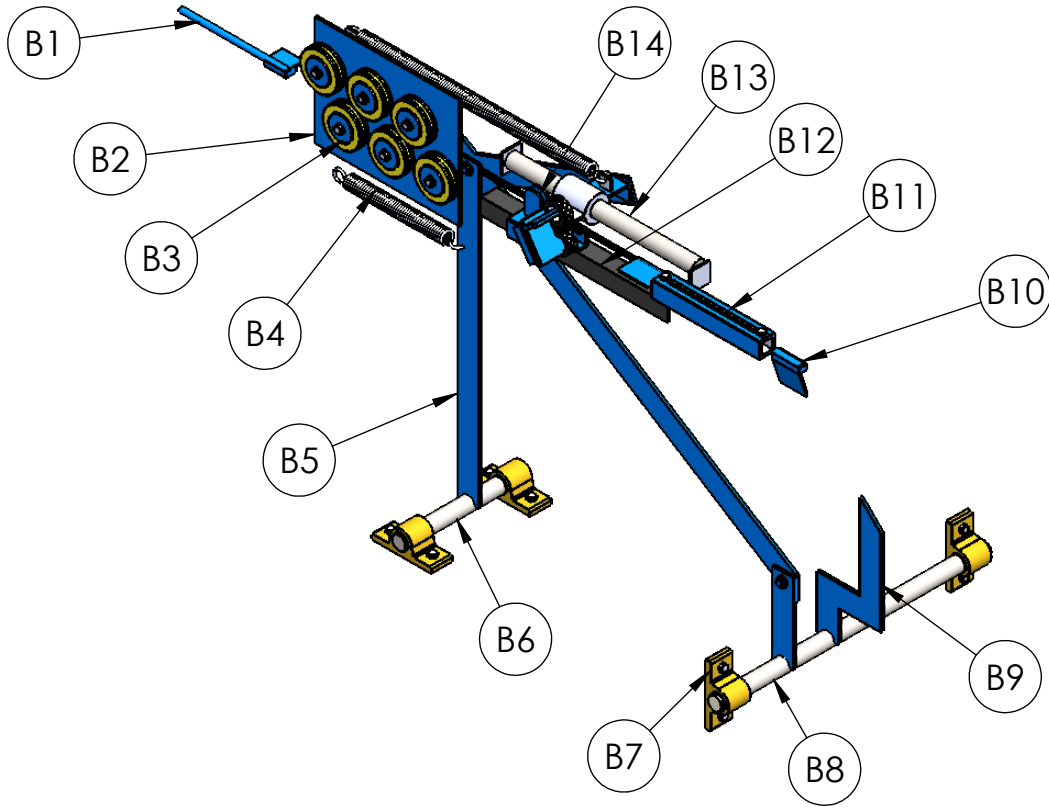
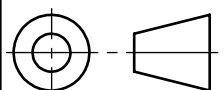
DILARANG MENGGANDAKAN, MENYALIN, MEMINDAHTANGKAN GAMBAR INI TANPA IZIN TERTULIS DARI POLITEKNIK NEGERI CILACAP

| 4   |                        | 3            |                    |                     | 2   |                   |                   |        |  |
|---|------------------------|--------------|--------------------|---------------------|---|-------------------|-------------------|--------|--|
| No.   | Perubahan              | Tanggal      | Nama               | No.                 | Perubahan   | Tanggal           | Nama              |        |  |
|    |                        |              |                    |                     |   |                   |                   |        |  |
| 1   | PENGUMPAN BETON        | -            | -                  | -                   | B14   |                   | ORDER             |        |  |
| 1   | POROS PENGUMPAN 3      | S45C         | Ø25 mm             | -                   | B13   |                   | PRODUKSI          |        |  |
| 1   | DUDUKAN PENGUMPAN      | BAR SIKU     | LIHAT DETAIL       | -                   | B12   |                   | PRODUKSI          |        |  |
| 1   | RELL BETON 3           | SS           | LIHAT DETAIL       | -                   | B11   |                   | PRODUKSI          |        |  |
| 1   | RELL BETON 2           | SS           | LIHAT DETAIL       | -                   | B10   |                   | PRODUKSI          |        |  |
| 1   | PENGAIT PENGUMPAN      | SSC          | LIHAT DETAIL       | -                   | B9  |                   | PRODUKSI          |        |  |
| 1   | POROS PENGUMPAN 2      | S45C         | Ø25 mm             | -                   | B8  |                   | PRODUKSI          |        |  |
| 4   | PILLOW BLOCK UCP 205   | -            | Ø25 mm             | -                   | B7  |                   | ORDER             |        |  |
| 1   | POROS PENGUMPAN 1      | S45C         | Ø25 mm             | -                   | B6  |                   | PRODUKSI          |        |  |
| 1   | RANGKA PENGUMPAN       | SSC          | LIHAT DETAIL       | -                   | B5  |                   | PRODUKSI          |        |  |
| 2   | PEGAS                  | -            | -                  | -                   | B4  |                   | ORDER             |        |  |
| 6   | RODA PENGUMPAN         | -            | -                  | -                   | B3  |                   | ORDER             |        |  |
| 1   | DUDUKAN RODA PENGUMPAN | SSC          | LIHAT DETAIL       | -                   | B2  |                   | PRODUKSI          |        |  |
| 1   | RELL BETON 1           | SS           | LIHAT DETAIL       | -                   | B1  |                   | PRODUKSI          |        |  |
| <b>JML</b>  | <b>NAMA BAGIAN</b>     | <b>BAHAN</b> | <b>UKURAN JADI</b> | <b>UKURAN KASAR</b> | <b>NO. ID</b>   | <b>KETERANGAN</b> |                   |        |  |
| >   | 0                      | 6            | 30                 | 120                 | 400   | 1000              | PENERJAAN LANJUT: |        | NO. ORDER<br>PROYEKSI<br> |
| <   | 6                      | 30           | 120                | 400                 | 1000  | 2000              |                   |        |  |
| Tol   | +0.1                   | +0.2         | +0.3               | +0.5                | +0.8  | +1.2              |                   |        |  |
| Nama:   |                        |              |                    |                     | <b>Skala</b><br><b>1:10</b>   | DIGAMBAR          | 10-4-23           | DITO   |  |
| <b>SISTEM PENGUMPAN</b>   |                        |              |                    |                     |   | DIPERIKSA         |                   | PUJONO |  |
|   |                        |              |                    |                     |   | DISAHKAN          |                   | PUJONO |  |
|   |                        |              |                    |                     |   |                   |                   |        |  |
| No. Assy:   |                        |              |                    |                     | FORMAT  | SATUAN            | NO. GAMBAR:       |        |  |
|  <b>Politeknik Negeri Cilacap, Jurusan Teknik Mesin</b><br>Jl. Dr. Soetomo, No. 01, Sidakaya, Cilacap, 53212<br>Telp: 0282-533329, E-mail: tmpnc@politeknikcilacap.ac.id |                        |              |                    |                     | A4  | mm                | <b>NO. 02/TM</b>  |        |  |
|   |                        |              |                    |                     | PENGANTI DARI: <span style="margin-left: 200px;">3</span> <span style="margin-left: 200px;">2</span> <span style="margin-left: 200px;">1</span><br>DIGANTI DENGAN |                   |                   |        |  |

|     |           |         |      |
|-----|-----------|---------|------|
| 4   | 3         | 2       |      |
| No. | Perubahan | Tanggal | Nama |
| No. | Perubahan | Tanggal | Nama |

F

E

D

C

B

A

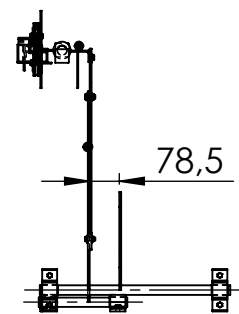
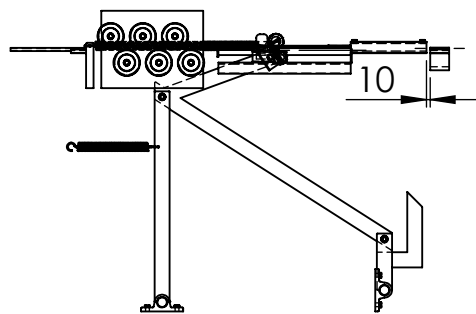
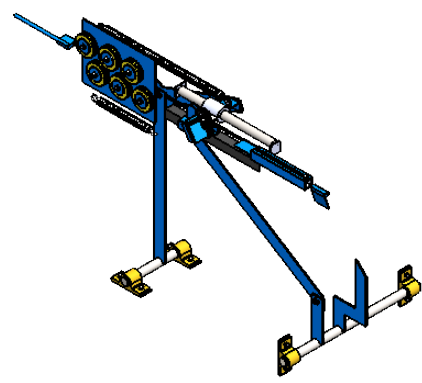
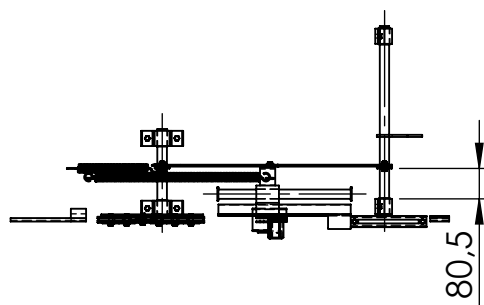

|            |                    |              |                    |                     |               |                   |
|------------|--------------------|--------------|--------------------|---------------------|---------------|-------------------|
| 1          | SISTEM PENGUMPAN   | -            | LIHAT DETAIL       | -                   | B             | -                 |
| <b>JML</b> | <b>NAMA BAGIAN</b> | <b>BAHAN</b> | <b>UKURAN JADI</b> | <b>UKURAN KASAR</b> | <b>NO. ID</b> | <b>KETERANGAN</b> |
| >          | 0                  | 6            | 30                 | 120                 | 400           | 1000              |
| <          | 6                  | 30           | 120                | 400                 | 1000          | 2000              |
| <b>Tol</b> | <b>+0.1</b>        | <b>+0.2</b>  | <b>+0.3</b>        | <b>+0.5</b>         | <b>+0.8</b>   | <b>+1.2</b>       |

PENGERJAAN LANJUT:

NO. ORDER

PROYEKSI

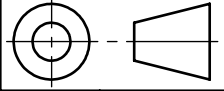

Nama:

## SISTEM PENGUMPAN

No. Assy:

**Skala**

1:20

|           |         |        |
|-----------|---------|--------|
| DIGAMBAR  | 10-4-23 | DITO   |
| DIPERIKSA |         | PUJONO |
| DISAHKAN  |         | PUJONO |



**Politeknik Negeri Cilacap, Jurusan Teknik Mesin**  
 Jl. Dr. Soetomo, No. 01, Sidakaya, Cilacap, 53212  
 Telp: 0282-533329, E-mail: tmpnc@politeknikcilacap.ac.id

**FORMAT**  
A4

**SATUAN**  
mm

**NO. GAMBAR:**  
**NO. 03/TM**

4

3

2

1

F

E

D

C

B

A

4

3

2

| No. | Perubahan | Tanggal | Nama | No. | Perubahan | Tanggal | Nama |
|-----|-----------|---------|------|-----|-----------|---------|------|
| △   |           |         |      | △   |           |         |      |

F

F

E

E

D

D

C

C

B

B

A

A

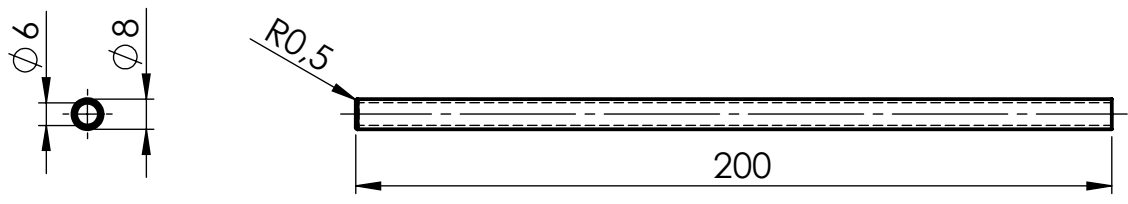
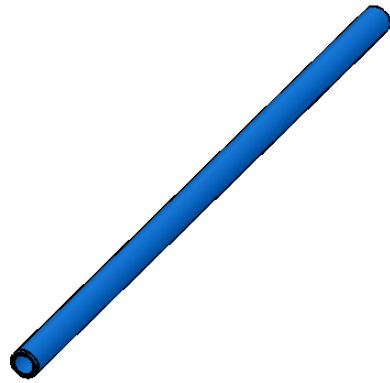

|     |              |      |      |      |      |       |                    |              |          |            |
|-----|--------------|------|------|------|------|-------|--------------------|--------------|----------|------------|
| 1   | RELL BETON 1 |      |      |      |      | SS    | LIHAT DETAIL       | -            | B1       | PRODUKSI   |
| JML | NAMA BAGIAN  |      |      |      |      | BAHAN | UKURAN JADI        | UKURAN KASAR | NO. ID   | KETERANGAN |
| >   | 0            | 6    | 30   | 120  | 400  | 1000  | Pengerjaan Lanjut: | NO. ORDER    | PROYEKSI |            |
| <   | 6            | 30   | 120  | 400  | 1000 | 2000  |                    |              |          |            |
| Tol | +0.1         | +0.2 | +0.3 | +0.5 | +0.8 | +1.2  |                    |              |          |            |

|   |                         |           |         |        |
|---|-------------------------|-----------|---------|--------|
| Nama:<br><br><h1>RELL BETON 1</h1><br><br>No. Assy: | <b>Skala</b><br><br>1:2 | DIGAMBAR  | 10-4-23 | DITO   |
|   |                         | DIPERIKSA |         | PUJONO |
|   |                         | DISAHKAN  |         | PUJONO |

|   |        |        |                  |
|---|--------|--------|------------------|
| <b>Politeknik Negeri Cilacap, Jurusan Teknik Mesin</b><br>Jl. Dr. Soetomo, No. 01, Sidakaya, Cilacap, 53212<br>Telp: 0282-533329, E-mail: tmpnc@politeknikcilacap.ac.id | FORMAT | SATUAN | NO. GAMBAR:      |
|   | A4     | mm     | <b>NO. 04/TM</b> |

DILARANG MENGGANDAKAN, MENYALIN, MEMINDAHTANGKAN GAMBAR INI TANPA IZIN TERTULIS DARI POLITEKNIK NEGERI CILACAP

PENGGANTI DARI:

DIGANTI DENGAN

4

3

2

1

4

3

2

| No. | Perubahan | Tanggal | Nama | No. | Perubahan | Tanggal | Nama |
|-----|-----------|---------|------|-----|-----------|---------|------|
| △   |           |         |      | △   |           |         |      |

F

F

E

E

D

D

C

C

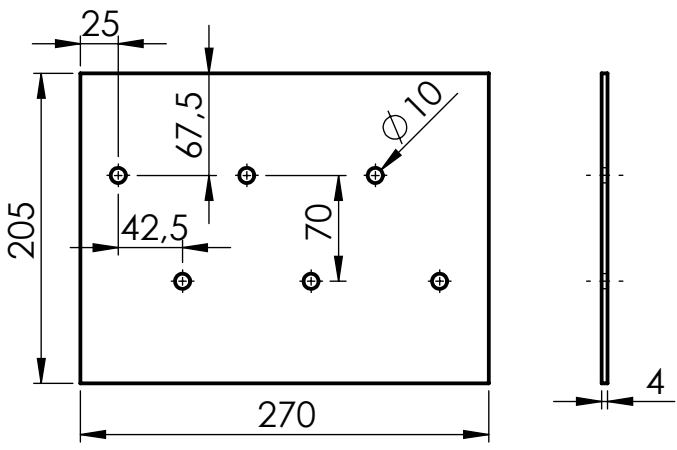
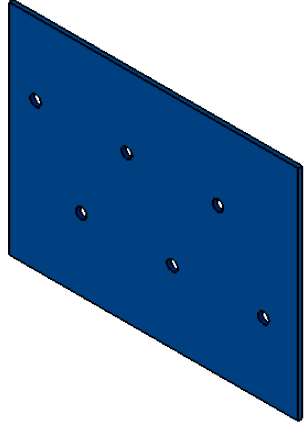

|            |                        |              |                    |                     |               |                   |
|------------|------------------------|--------------|--------------------|---------------------|---------------|-------------------|
| 1          | DUDUKAN RODA PENGUMPAN | SSC          | LIHAT DETAIL       | -                   | B2            | PRODUKSI          |
| <b>JML</b> | <b>NAMA BAGIAN</b>     | <b>BAHAN</b> | <b>UKURAN JADI</b> | <b>UKURAN KASAR</b> | <b>NO. ID</b> | <b>KETERANGAN</b> |
| >          | 0                      | 6            | 30                 | 120                 | 400           | 1000              |
| <          | 6                      | 30           | 120                | 400                 | 1000          | 2000              |
| Tol        | +0.1                   | +0.2         | +0.3               | +0.5                | +0.8          | +1.2              |

PENGERJAAN LANJUT:

NO. ORDER

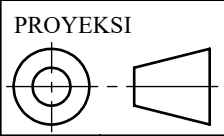

|   |                         |           |         |        |
|---|-------------------------|-----------|---------|--------|
| Nama:<br><br><b>DUDUKAN RODA PENGUMPAN</b><br><br>No. Assy: | <b>Skala</b><br><br>1:5 | DIGAMBAR  | 10-4-23 | DITO   |
|   |                         | DIPERIKSA |         | PUJONO |
|   |                         | DISAHKAN  |         | PUJONO |
|   |                         |           |         |        |

|   |               |               |                    |
|---|---------------|---------------|--------------------|
|  <b>Politeknik Negeri Cilacap, Jurusan Teknik Mesin</b><br>Jl. Dr. Soetomo, No. 01, Sidakaya, Cilacap, 53212<br>Telp: 0282-533329, E-mail: tmpnc@politeknikcilacap.ac.id | <b>FORMAT</b> | <b>SATUAN</b> | <b>NO. GAMBAR:</b> |
|   | A4            | mm            | <b>NO. 05/TM</b>   |

A

A

4

3

2

1

DILARANG MENGGANDAKAN, MENYALIN, MEMINDAHTANGKAN GAMBAR INI TANPA IZIN TERTULIS DARI POLITEKNIK NEGERI CILACAP

PENGGANTI DARI:

DIGANTI DENGAN

DILARANG MENGGANDAKAN, MENYALIN, MEMINDAHTANGKAN GAMBAR INI TANPA IZIN TERTULIS DARI POLITEKNIK NEGERI CILACAP

|     |           |         |      |
|-----|-----------|---------|------|
| 4   | 3         | 2       |      |
| No. | Perubahan | Tanggal | Nama |
| No. | Perubahan | Tanggal | Nama |

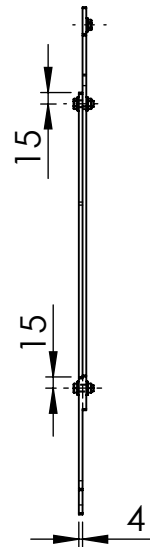
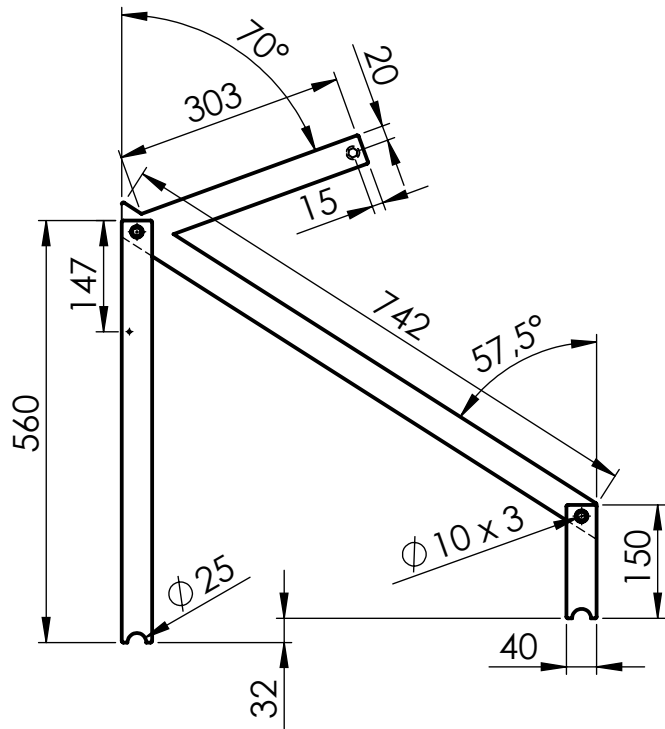
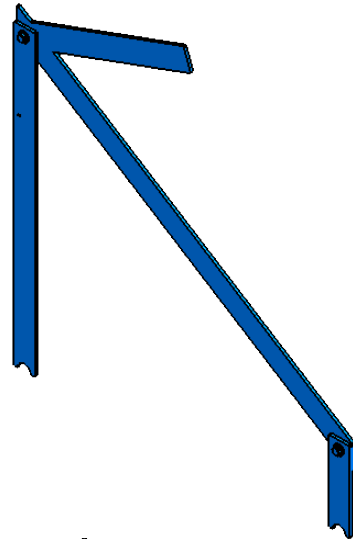

|   |                               |       |                   |               |               |                    |        |
|---|-------------------------------|-------|-------------------|---------------|---------------|--------------------|--------|
| 1   | RANGKA PENGUMPAN              | SSC   | LIHAT DETAIL      | -             | B5            | PRODUKSI           |        |
| JML   | NAMA BAGIAN                   | BAHAN | UKURAN JADI       | UKURAN KASAR  | NO. ID        | KETERANGAN         |        |
| >   | 0 6 30 120 400 1000           | 1000  | PENERJAAN LANJUT: |               | NO. ORDER     | PROYEKSI           |        |
| <   | 6 30 120 400 1000 2000        | 2000  |                   |               |               |                    |        |
| Tol   | ±0.1 ±0.2 ±0.3 ±0.5 ±0.8 ±1.2 |       |                   |               |               |                    |        |
| Nama:   |                               |       |                   | <b>Skala</b>  | DIGAMBAR      | 10-4-23            | DITO   |
| <b>RANGKA PENGUMPAN</b>   |                               |       |                   | 1:10          | DIPERIKSA     |                    | PUJONO |
| No. Assy:   |                               |       |                   |               | DISAHKAN      |                    | PUJONO |
|   |                               |       |                   |               |               |                    |        |
| <b>Politeknik Negeri Cilacap, Jurusan Teknik Mesin</b><br>Jl. Dr. Soetomo, No. 01, Sidakaya, Cilacap, 53212<br>Telp: 0282-533329, E-mail: tmpnc@politeknikcilacap.ac.id |                               |       |                   | <b>FORMAT</b> | <b>SATUAN</b> | <b>NO. GAMBAR:</b> |        |
|   |                               |       |                   | A4            | mm            | <b>NO. 06/TM</b>   |        |

PENGGANTI DARI:

DIGANTI DENGAN

4

3

2

|     |           |         |      |     |           |         |      |
|-----|-----------|---------|------|-----|-----------|---------|------|
| No. | Perubahan | Tanggal | Nama | No. | Perubahan | Tanggal | Nama |
| △   |           |         |      | △   |           |         |      |

F

F

E

E

D

D

C

C

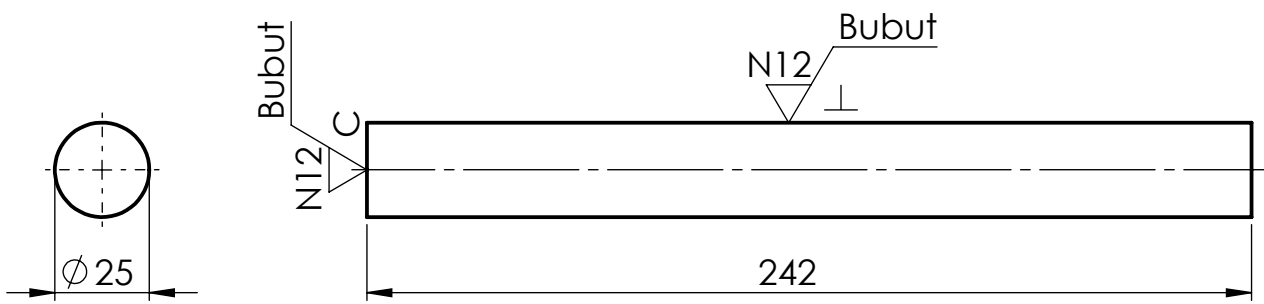
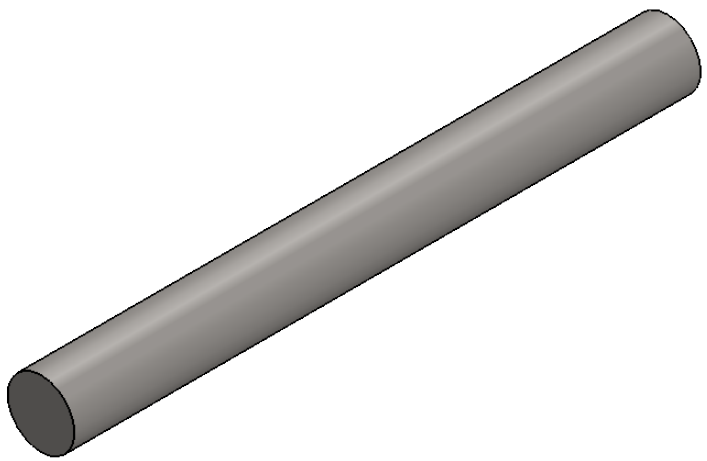

B

B

A

A

|     |                   |      |      |      |      |       |                    |              |          |            |
|-----|-------------------|------|------|------|------|-------|--------------------|--------------|----------|------------|
| 1   | POROS PENGUMPAN 1 |      |      |      |      | S45C  | LIHAT DETAIL       | -            | B6       | PRODUKSI   |
| JML | NAMA BAGIAN       |      |      |      |      | BAHAN | UKURAN JADI        | UKURAN KASAR | NO. ID   | KETERANGAN |
| >   | 0                 | 6    | 30   | 120  | 400  | 1000  | Pengerjaan Lanjut: | NO. ORDER    | PROYEKSI |            |
| <   | 6                 | 30   | 120  | 400  | 1000 | 2000  |                    |              |          |            |
| Tol | +0.1              | +0.2 | +0.3 | +0.5 | +0.8 | +1.2  |                    |              |          |            |

|   |                         |           |         |        |
|---|-------------------------|-----------|---------|--------|
| Nama:<br><br><h2 style="text-align: center;">POROS PENGUMPAN 1</h2> | <b>Skala</b><br><br>1:2 | DIGAMBAR  | 10-4-23 | DITO   |
|   |                         | DIPERIKSA |         | PUJONO |
|   |                         | DISAHKAN  |         | PUJONO |

|   |        |        |                  |
|---|--------|--------|------------------|
| <b>Politeknik Negeri Cilacap, Jurusan Teknik Mesin</b><br>Jl. Dr. Soetomo, No. 01, Sidakaya, Cilacap, 53212<br>Telp: 0282-533329, E-mail: tmpnc@politeknikcilacap.ac.id | FORMAT | SATUAN | NO. GAMBAR:      |
|   | A4     | mm     | <b>NO. 07/TM</b> |

4

3

2

1

PENGGANTI DARI:

DIGANTI DENGAN

DILARANG MENGGANDAKAN, MENYALIN, MEMINDAHKANKAN GAMBAR INI  
 TANPA IZIN TERTULIS DARI POLITEKNIK NEGERI CILACAP



|     |           |         |      |
|-----|-----------|---------|------|
| 4   | 3         | 2       |      |
| No. | Perubahan | Tanggal | Nama |
| No. | Perubahan | Tanggal | Nama |

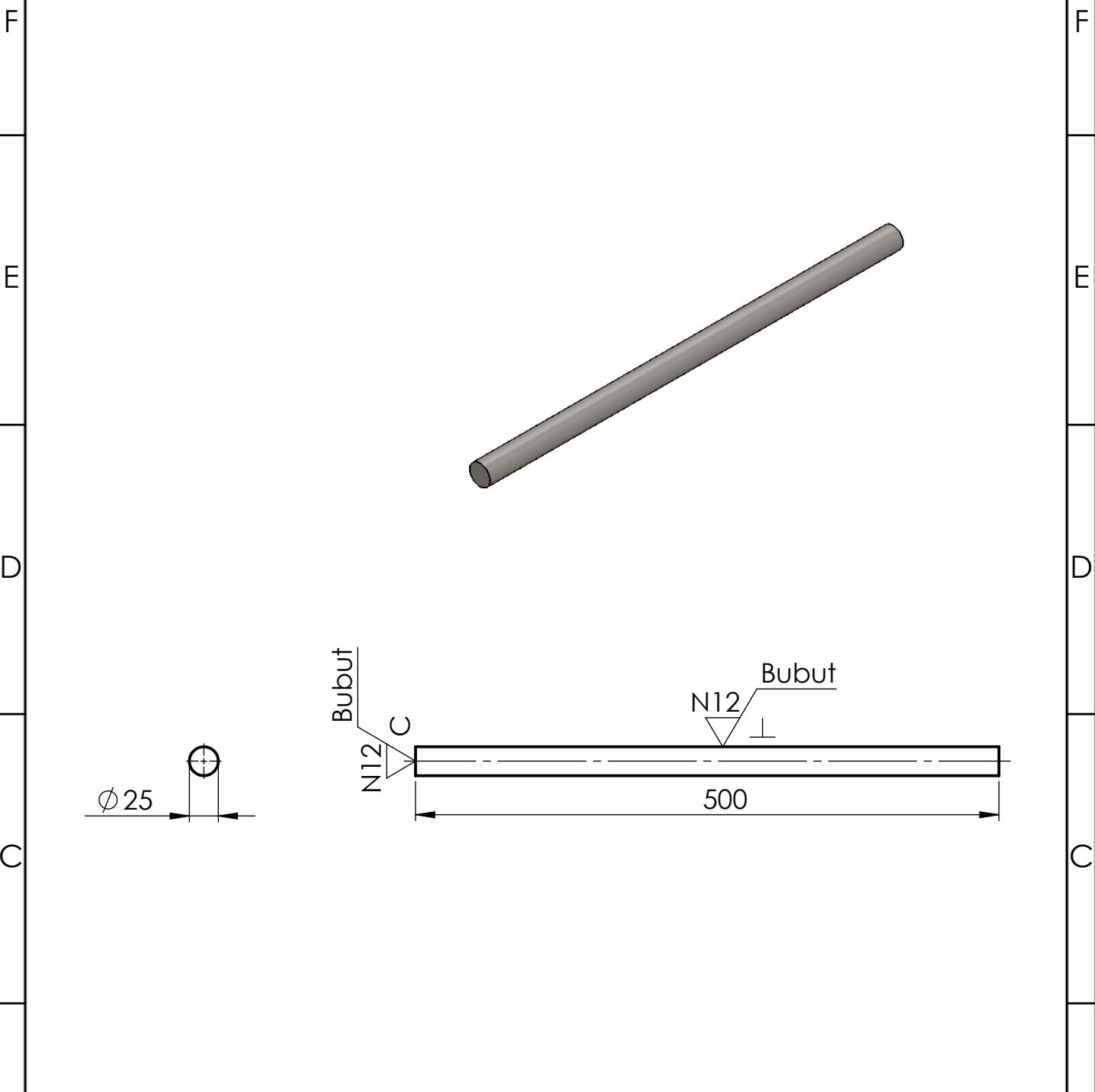

|            |                    |              |                    |                     |               |                   |
|------------|--------------------|--------------|--------------------|---------------------|---------------|-------------------|
| 1          | POROS PENGUMPAN 2  | S45C         | LIHAT DETAIL       | -                   | B8            | PRODUKSI          |
| <b>JML</b> | <b>NAMA BAGIAN</b> | <b>BAHAN</b> | <b>UKURAN JADI</b> | <b>UKURAN KASAR</b> | <b>NO. ID</b> | <b>KETERANGAN</b> |
| >          | 0                  | 6            | 30                 | 120                 | 400           | 1000              |
| <          | 6                  | 30           | 120                | 400                 | 1000          | 2000              |
| <b>Tol</b> | $\pm 0.1$          | $\pm 0.2$    | $\pm 0.3$          | $\pm 0.5$           | $\pm 0.8$     | $\pm 1.2$         |

|   |                         |  |                          |  |
|---|-------------------------|--|--------------------------|--|
| Nama:<br><br><h2 style="text-align: center;">POROS PENGUMPAN 2</h2> No. Assy: | <b>Skala</b><br><br>1:5 | DIGAMBAR<br>10-4-23<br>DIPERIKSA<br>DISAHKAN | DITO<br>PUJONO<br>PUJONO | <b>NO. GAMBAR:</b><br><b>NO. 08/TM</b> |
|---|-------------------------|--|--------------------------|--|

|   |   |   |  |
|---|---|---|--|
| 4 | 3 | 2 |  |
|---|---|---|--|

DILARANG MENGGANDAKAN, MENYALIN, MEMINDAHTANGKAN GAMBAR INI TANPA IZIN TERTULIS DARI POLITEKNIK NEGERI CILACAP

|     |           |         |      |
|-----|-----------|---------|------|
| 4   | 3         | 2       |      |
| No. | Perubahan | Tanggal | Nama |
| No. | Perubahan | Tanggal | Nama |

The drawing shows a lifting hook with the following dimensions and features:

- Top horizontal section: width 40.
- Vertical section: height 100.
- Bottom horizontal section: width 80.
- Bottom fillet: radius R12.5.
- Vertical section: width 40.
- Vertical section: 45° chamfer.
- Vertical section: total height 160.
- Vertical section: bottom width 5.
- Welds: Two SMAW welds are indicated on the vertical section.

|     |                               |       |                   |              |           |            |
|-----|-------------------------------|-------|-------------------|--------------|-----------|------------|
| 1   | PENGAIT PENGUMPAN             | SSC   | LIHAT DETAIL      | -            | B9        | PRODUKSI   |
| JML | NAMA BAGIAN                   | BAHAN | UKURAN JADI       | UKURAN KASAR | NO. ID    | KETERANGAN |
| >   | 0 6 30 120 400                | 1000  | PENERJAAN LANJUT: |              | NO. ORDER | PROYEKSI   |
| <   | 6 30 120 400 1000             | 2000  |                   |              |           |            |
| Tol | ±0.1 ±0.2 ±0.3 ±0.5 ±0.8 ±1.2 |       |                   |              |           |            |

|                          |               |               |                    |        |
|--------------------------|---------------|---------------|--------------------|--------|
| Nama:                    | <b>Skala</b>  | DIGAMBAR      | 10-4-23            | DITO   |
| <b>PENGAIT PENGUMPAN</b> | 1:5           | DIPERIKSA     |                    | PUJONO |
|                          |               | DISAHKAN      |                    | PUJONO |
|                          |               |               |                    |        |
| No. Assy:                | <b>FORMAT</b> | <b>SATUAN</b> | <b>NO. GAMBAR:</b> |        |
|                          | A4            | mm            | <b>NO. 09/TM</b>   |        |

**Politeknik Negeri Cilacap, Jurusan Teknik Mesin**  
 Jl. Dr. Soetomo, No. 01, Sidakaya, Cilacap, 53212  
 Telp: 0282-533329, E-mail: tmpnc@politeknikcilacap.ac.id

PENGGANTI DARI: 4

DIGANTI DENGAN: 3

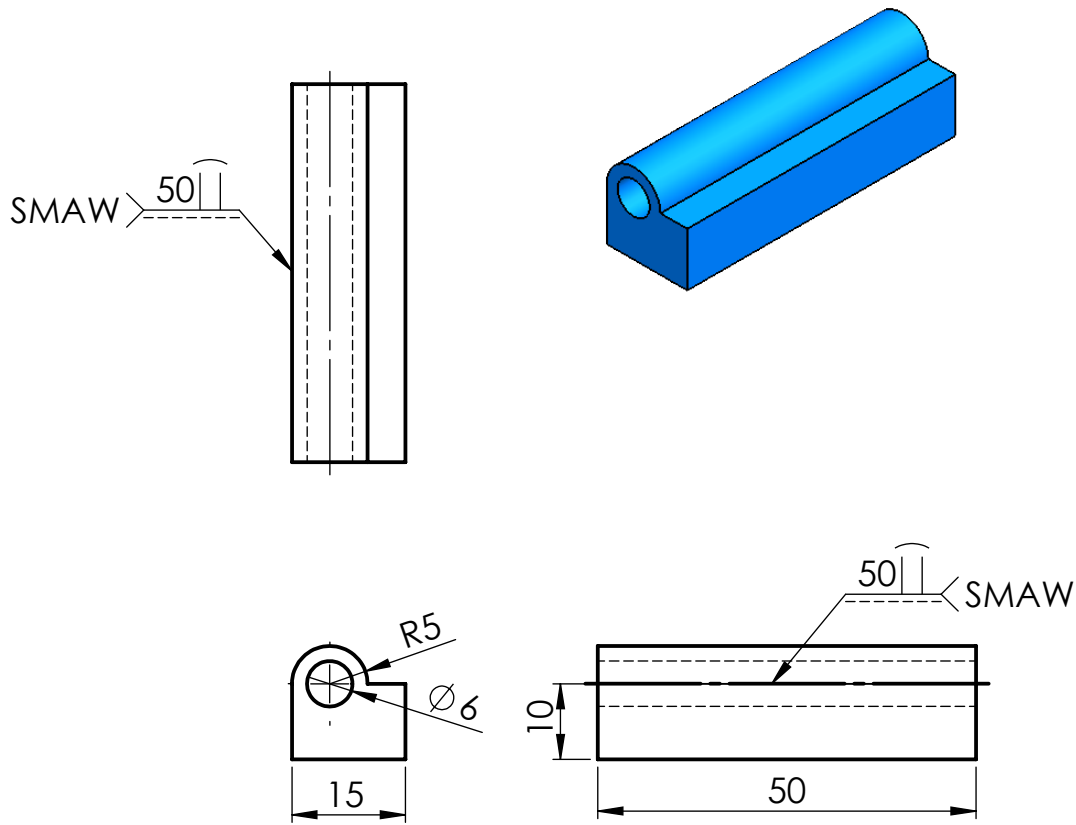

|   |                    |      |      |      |      |              |                    |                     |                     |  |        |
|---|--------------------|------|------|------|------|--------------|--------------------|---------------------|---------------------|--|--------|
| 1   | RELL BETON 2       |      |      |      |      | SS           | LIHAT DETAIL       | -                   | B10                 | PRODUKSI                               |        |
| <b>JML</b>  | <b>NAMA BAGIAN</b> |      |      |      |      | <b>BAHAN</b> | <b>UKURAN JADI</b> | <b>UKURAN KASAR</b> | <b>NO. ID</b>       | <b>KETERANGAN</b>                      |        |
| >   | 0                  | 6    | 30   | 120  | 400  | 1000         | Pengerjaan Lanjut: | NO. ORDER           | PROYEKSI            |  |        |
| <   | 6                  | 30   | 120  | 400  | 1000 | 2000         |                    |                     |                     |  |        |
| Tol   | +0.1               | +0.2 | +0.3 | +0.5 | +0.8 | +1.2         |                    |                     |                     |  |        |
| Nama:<br><h2 style="text-align: center;">RELL BETON 2</h2> No. Assy:  |                    |      |      |      |      |              |                    | <b>Skala</b><br>1:1 | DIGAMBAR            | 10-4-23                                | DITO   |
|   |                    |      |      |      |      |              |                    |                     | DIPERIKSA           |  | PUJONO |
|   |                    |      |      |      |      |              |                    |                     | DISAHKAN            |  | PUJONO |
| <b>Politeknik Negeri Cilacap, Jurusan Teknik Mesin</b><br>Jl. Dr. Soetomo, No. 01, Sidakaya, Cilacap, 53212<br>Telp: 0282-533329, E-mail: tmpnc@politeknikcilacap.ac.id |                    |      |      |      |      |              |                    | <b>FORMAT</b><br>A4 | <b>SATUAN</b><br>mm | <b>NO. GAMBAR:</b><br><b>NO. 10/TM</b> |        |

DILARANG MENGGANDAKAN, MENYALIN, MEMINDAHTANGKAN GAMBAR INI TANPA IZIN TERTULIS DARI POLITEKNIK NEGERI CILACAP

4

3

2

|     |           |         |      |     |           |         |      |
|-----|-----------|---------|------|-----|-----------|---------|------|
| No. | Perubahan | Tanggal | Nama | No. | Perubahan | Tanggal | Nama |
| △   |           |         |      | △   |           |         |      |

F

F

E

E

D

D

C

C

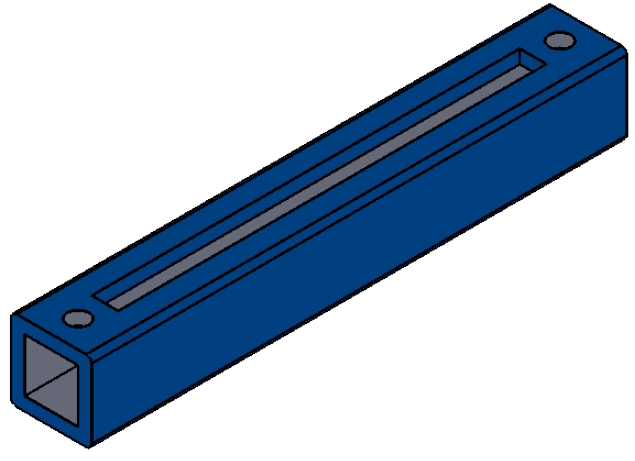
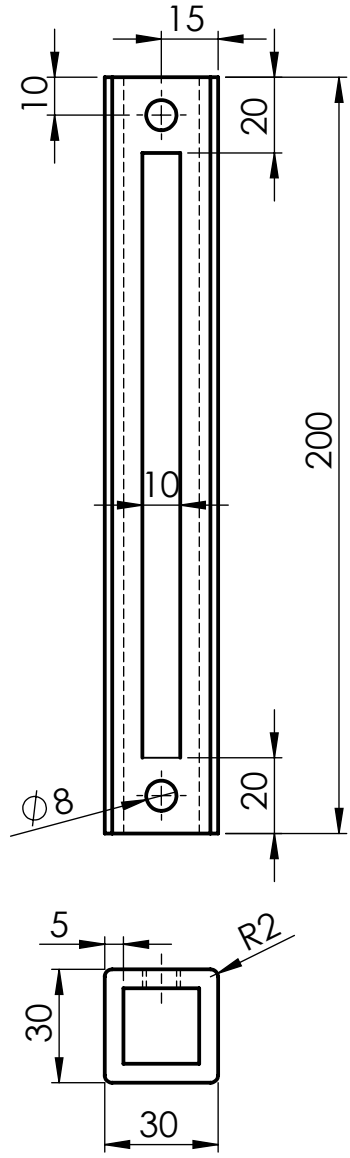

|     |              |      |      |      |      |       |                    |              |           |            |
|-----|--------------|------|------|------|------|-------|--------------------|--------------|-----------|------------|
| 1   | RELL BETON 3 |      |      |      |      | SS    | LIHAT DETAIL       | -            | B11       | PRODUKSI   |
| JML | NAMA BAGIAN  |      |      |      |      | BAHAN | UKURAN JADI        | UKURAN KASAR | NO. ID    | KETERANGAN |
| >   | 0            | 6    | 30   | 120  | 400  | 1000  | Pengerjaan Lanjut: |              | NO. ORDER | PROYEKSI   |
| <   | 6            | 30   | 120  | 400  | 1000 | 2000  |                    |              |           |            |
| Tol | +0.1         | +0.2 | +0.3 | +0.5 | +0.8 | +1.2  |                    |              |           |            |

|           |                     |       |           |         |        |
|-----------|---------------------|-------|-----------|---------|--------|
| Nama:     | <b>RELL BETON 3</b> | Skala | DIGAMBAR  | 10-4-23 | DITO   |
|           |                     |       | DIPERIKSA |         | PUJONO |
|           |                     |       | DISAHKAN  |         | PUJONO |
| No. Assy: |                     |       |           |         |        |

|   |        |        |                  |
|---|--------|--------|------------------|
| <b>Politeknik Negeri Cilacap, Jurusan Teknik Mesin</b><br>Jl. Dr. Soetomo, No. 01, Sidakaya, Cilacap, 53212<br>Telp: 0282-533329, E-mail: tmpnc@politeknikcilacap.ac.id | FORMAT | SATUAN | NO. GAMBAR:      |
|   | A4     | mm     | <b>NO. 11/TM</b> |

DILARANG MENGGANDAKAN, MENYALIN, MEMINDAHTANGKAN GAMBAR INI TANPA IZIN TERTULIS DARI POLITEKNIK NEGERI CILACAP

PENGANTI DARI:

DIGANTI DENGAN:

4

3

2

1

DILARANG MENGGANDAKAN, MENYALIN, MEMINDAHTANGKAN GAMBAR INI TANPA IZIN TERTULIS DARI POLITEKNIK NEGERI CILACAP

|     |           |         |      |
|-----|-----------|---------|------|
| 4   | 3         | 2       |      |
| No. | Perubahan | Tanggal | Nama |
| No. | Perubahan | Tanggal | Nama |
| F   |           |         | F    |
| E   |           |         | E    |
| D   |           |         | D    |
| C   |           |         | C    |
| B   |           |         | B    |
| A   |           |         | A    |
| 4   | 3         | 2       | 1    |

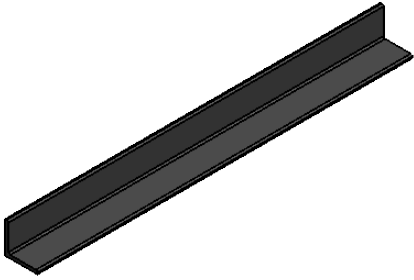

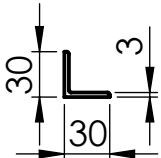

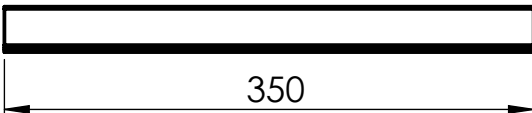

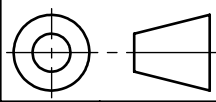
|     |                   |          |              |              |        |            |   |
|-----|-------------------|----------|--------------|--------------|--------|------------|---|
| 1   | DUDUKAN PENGUMPAN | BAR SIKU | LIHAT DETAIL | -            | B12    | PRODUKSI   |   |
| JML | NAMA BAGIAN       | BAHAN    | UKURAN JADI  | UKURAN KASAR | NO. ID | KETERANGAN |   |
| >   | 0                 | 6        | 30           | 120          | 400    | 1000       | PENERJAAN LANJUT:<br>NO. ORDER<br>PROYEKSI<br> |
| <   | 6                 | 30       | 120          | 400          | 1000   | 2000       |   |
| Tol | +0.1              | +0.2     | +0.3         | +0.5         | +0.8   | +1.2       |   |

|   |                         |                                   |  |                          |
|---|-------------------------|-----------------------------------|--|--------------------------|
| Nama:<br><br><h2 style="text-align: center;">DUDUKAN PENGUMPAN</h2> No. Assy:   | <b>Skala</b><br><br>1:5 | DIGAMBAR<br>DIPERIKSA<br>DISAHKAN | 10-4-23<br><br><br>                    | DITO<br>PUJONO<br>PUJONO |
|  <b>Politeknik Negeri Cilacap, Jurusan Teknik Mesin</b><br>Jl. Dr. Soetomo, No. 01, Sidakaya, Cilacap, 53212<br>Telp: 0282-533329, E-mail: tmpnc@politeknikcilacap.ac.id | <b>FORMAT</b><br>A4     | <b>SATUAN</b><br>mm               | <b>NO. GAMBAR:</b><br><b>NO. 12/TM</b> |                          |

PENGGANTI DARI:

DIGANTI DENGAN

|     |           |         |      |
|-----|-----------|---------|------|
| 4   | 3         | 2       |      |
| No. | Perubahan | Tanggal | Nama |
| No. | Perubahan | Tanggal | Nama |

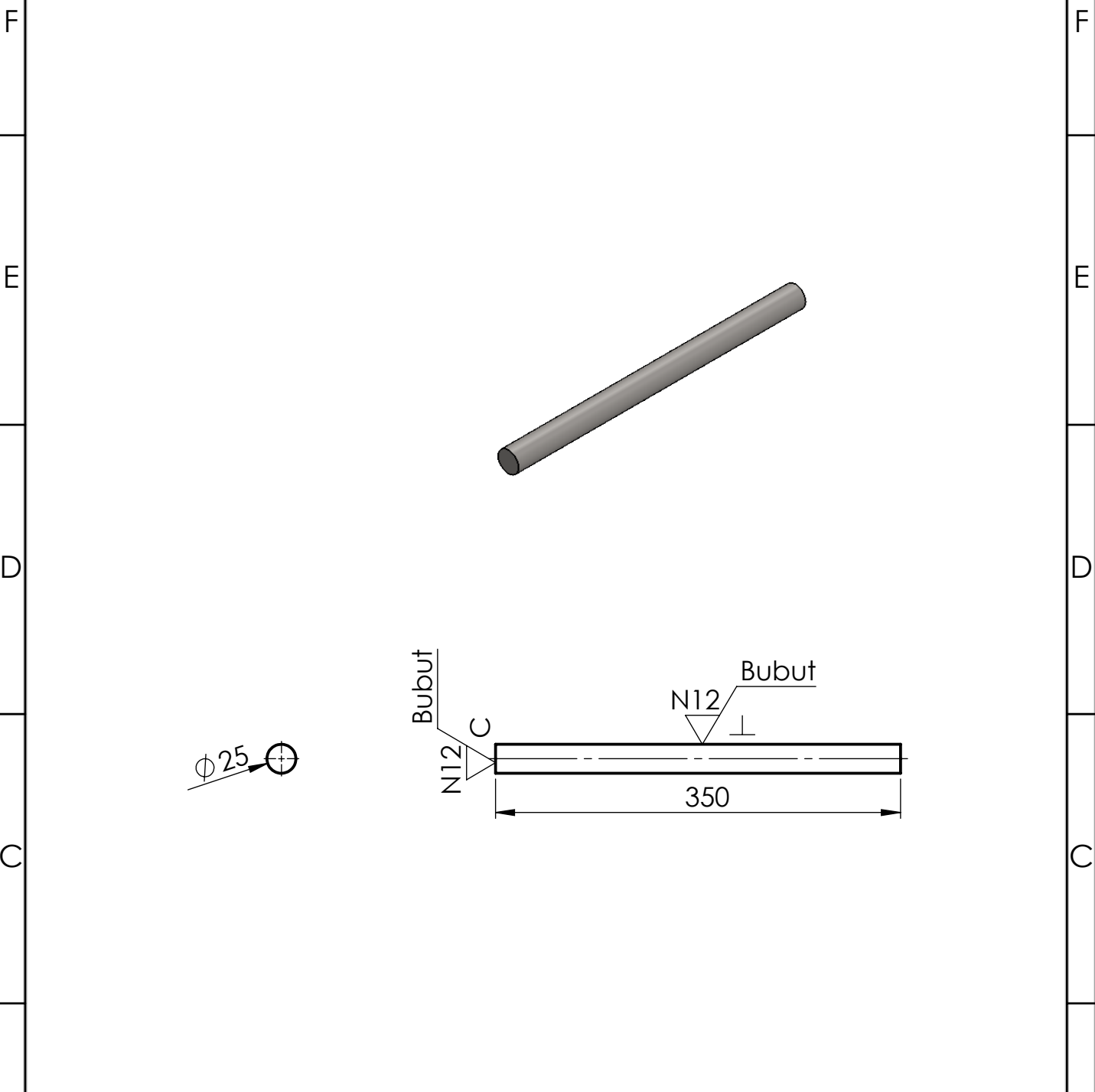

|            |   |              |                    |                     |               |                   |
|------------|---|--------------|--------------------|---------------------|---------------|-------------------|
| 1          | POROS PENGUMPAN 3   | S45C         | LIHAT DETAIL       | -                   | B13           | PRODUKSI          |
| <b>JML</b> | <b>NAMA BAGIAN</b>  | <b>BAHAN</b> | <b>UKURAN JADI</b> | <b>UKURAN KASAR</b> | <b>NO. ID</b> | <b>KETERANGAN</b> |
| >          | 0    6    30    120    400  | 1000         | Pengerjaan Lanjut: |                     | NO. ORDER     | PROYEKSI          |
| <          | 6    30    120    400    1000   | 2000         |                    |                     |               |                   |
| <b>Tol</b> | <b>+0.1</b> <b>+0.2</b> <b>+0.3</b> <b>+0.5</b> <b>+0.8</b> <b>+1.2</b> |              |                    |                     |               |                   |

|   |                         |  |  |
|---|-------------------------|--|--|
| Nama:<br><br><h2 style="text-align: center;">POROS PENGUMPAN 3</h2> No. Assy:   | <b>Skala</b><br><br>1:5 | DIGAMBAR<br>10-4-23<br>DITO<br>DIPERIKSA<br>PUJONO<br>DISAHKAN<br>PUJONO | <b>NO. GAMBAR:</b><br><b>NO. 13/TM</b> |
| <b>Politeknik Negeri Cilacap, Jurusan Teknik Mesin</b><br>Jl. Dr. Soetomo, No. 01, Sidakaya, Cilacap, 53212<br>Telp: 0282-533329, E-mail: tmpnc@politeknikcilacap.ac.id |                         | <b>FORMAT</b><br>A4  | <b>SATUAN</b><br>mm                    |

|   |   |   |  |
|---|---|---|--|
| 4 | 3 | 2 |  |
|---|---|---|--|

| No. | Perubahan | Tanggal | Nama | No. | Perubahan | Tanggal | Nama |
|-----|-----------|---------|------|-----|-----------|---------|------|
| ^   |           |         |      | ^   |           |         |      |

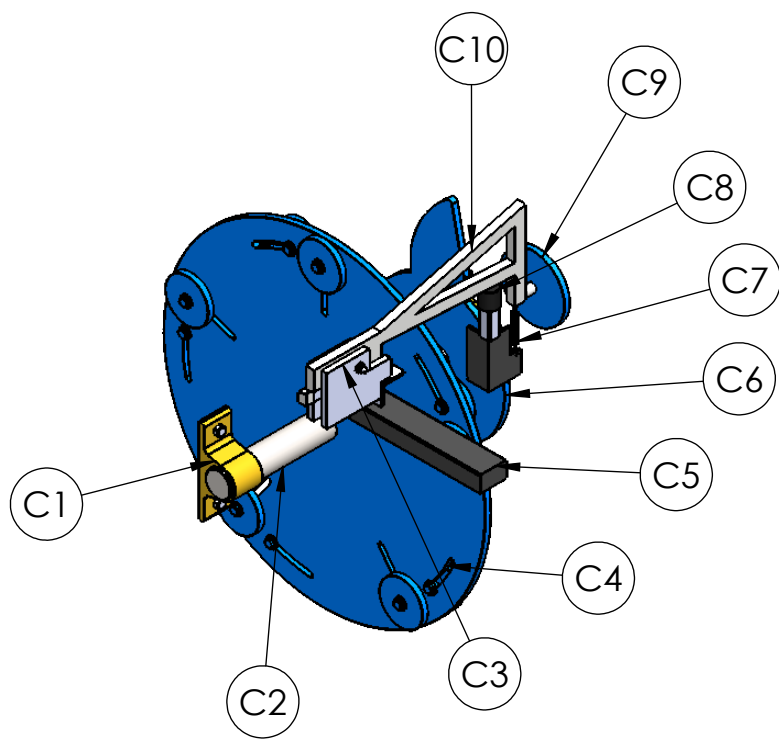

|   |                          |        |              |   |     |          |
|---|--------------------------|--------|--------------|---|-----|----------|
| 1 | PEMOTONG BEGEL           | SUP 3  | -            | - | C10 | ORDER    |
| 1 | PENGHANTAM PEMOTONG      | SSC    | LIHAT DETAIL | - | C9  | ORDER    |
| 1 | PEREDAM SUARA            | RUBBER | LIHAT DETAIL | - | C8  | PRODUKSI |
| 1 | PEGAS                    | -      | -            | - | C7  | ORDER    |
| 1 | FLYWHEEL PEMOTONG        | SSC    | LIHAT DETAIL | - | C6  | PRODUKSI |
| 1 | PENAHAN DUDUKAN PEMOTONG | UNP    | LIHAT DETAIL | - | C5  | PRODUKSI |
| 1 | FLYWHEEL                 | SSC    | LIHAT DETAIL | - | C4  | PRODUKSI |
| 2 | PENGUNCI PEMOTONG        | SSC    | LIHAT DETAIL | - | C3  | PRODUKSI |
| 1 | POROS FLYWHEEL           | S45C   | LIHAT DETAIL | - | C2  | PRODUKSI |
| 2 | PILLOW BLOCK UCP 321     | -      | Ø105         | - | C1  | ORDER    |

| JML | NAMA BAGIAN                                  | BAHAN              | UKURAN JADI | UKURAN KASAR | NO. ID | KETERANGAN |
|-----|--|--------------------|-------------|--------------|--------|------------|
| >   | 0    6    30    120    400    1000           | Pengerjaan Lanjut: |             | NO. ORDER    |        | PROYEKSI   |
| <   | 6    30    120    400    1000    2000        |                    |             |              |        |            |
| Tol | +0.1    +0.2    +0.3    +0.5    +0.8    +1.2 |                    |             |              |        |            |

|   |                          |                                   |   |                        |
|---|--------------------------|-----------------------------------|---|------------------------|
| Nama:<br><br><h2 style="text-align: center;">SISTEM PEMOTONG</h2> No. Assy:   | <b>Skala</b><br><br>1:10 | DIGAMBAR<br>DIPERIKSA<br>DISAHKAN | 10-4-23<br><br><br>PUJONO<br><br>PUJONO | DITO<br><br><br>PUJONO |
| <b>Politeknik Negeri Cilacap, Jurusan Teknik Mesin</b><br>Jl. Dr. Soetomo, No. 01, Sidakaya, Cilacap, 53212<br>Telp: 0282-533329, E-mail: tmpnc@politeknikcilacap.ac.id | <b>FORMAT</b><br>A4      | <b>SATUAN</b><br>mm               | <b>NO. GAMBAR:</b><br><b>NO. 14/TM</b>  |                        |

4

3

2

| No. | Perubahan | Tanggal | Nama | No. | Perubahan | Tanggal | Nama |
|-----|-----------|---------|------|-----|-----------|---------|------|
| △   |           |         |      | △   |           |         |      |

F

F

E

E

D

D

C

C

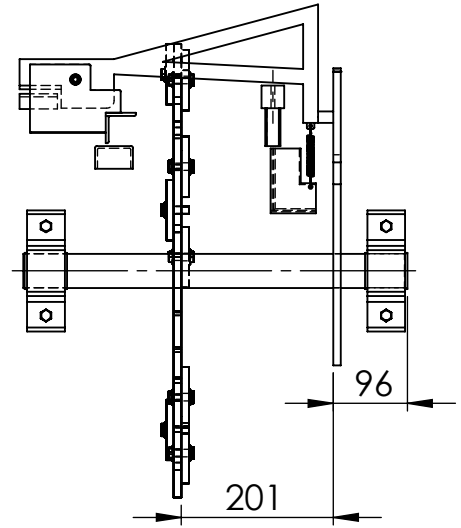
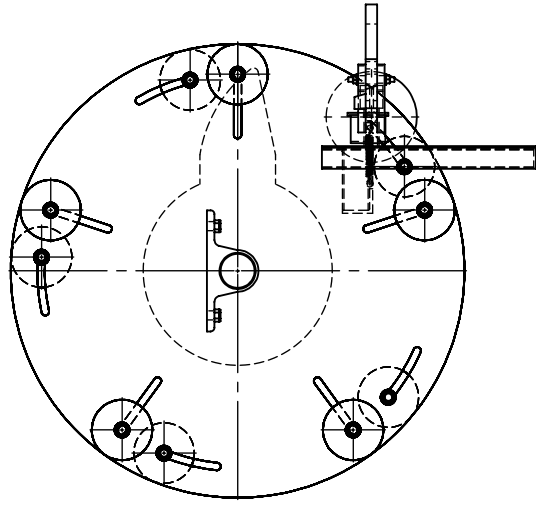
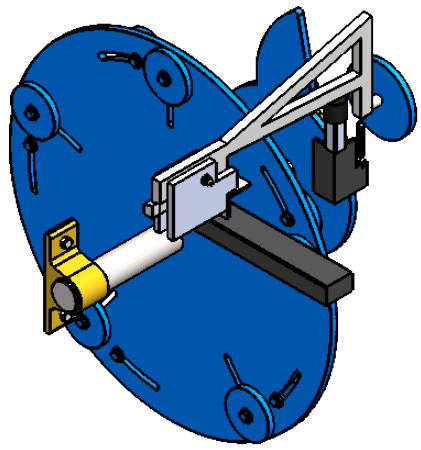
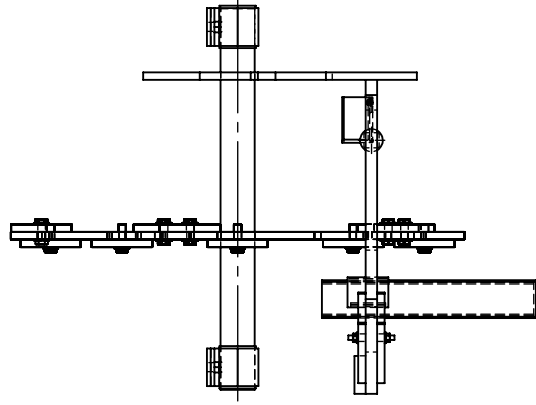

|     |                 |      |      |      |      |       |                    |              |           |            |
|-----|-----------------|------|------|------|------|-------|--------------------|--------------|-----------|------------|
| 1   | SISTEM PEMOTONG |      |      |      |      | -     | LIHAT DETAIL       | -            | C         | -          |
| JML | NAMA BAGIAN     |      |      |      |      | BAHAN | UKURAN JADI        | UKURAN KASAR | NO. ID    | KETERANGAN |
| >   | 0               | 6    | 30   | 120  | 400  | 1000  | Pengerjaan Lanjut: |              | NO. ORDER | PROYEKSI   |
| <   | 6               | 30   | 120  | 400  | 1000 | 2000  |                    |              |           |            |
| Tol | +0.1            | +0.2 | +0.3 | +0.5 | +0.8 | +1.2  |                    |              |           |            |

|           |                        |       |           |         |        |
|-----------|------------------------|-------|-----------|---------|--------|
| Nama:     | <b>SISTEM PEMOTONG</b> | Skala | DIGAMBAR  | 10-4-23 | DITO   |
|           |                        |       | DIPERIKSA |         | PUJONO |
|           |                        |       | DISAHKAN  |         | PUJONO |
| No. Assy: |                        | 1:10  |           |         |        |

|   |        |        |                  |
|---|--------|--------|------------------|
| <b>Politeknik Negeri Cilacap, Jurusan Teknik Mesin</b><br>Jl. Dr. Soetomo, No. 01, Sidakaya, Cilacap, 53212<br>Telp: 0282-533329, E-mail: tmpnc@politeknikcilacap.ac.id | FORMAT | SATUAN | NO. GAMBAR:      |
|   | A4     | mm     | <b>NO. 15/TM</b> |

DILARANG MENGGANDAKAN, MENYALIN, MEMINDAHTANGKAN GAMBAR INI TANPA IZIN TERTULIS DARI POLITEKNIK NEGERI CILAPAC

PENGGANTI DARI:

DIGANTI DENGAN

4

3

2

1

A

A

B

B



4

3

2

|     |           |         |      |     |           |         |      |
|-----|-----------|---------|------|-----|-----------|---------|------|
| No. | Perubahan | Tanggal | Nama | No. | Perubahan | Tanggal | Nama |
| △   |           |         |      | △   |           |         |      |

F

F

E

E

D

D

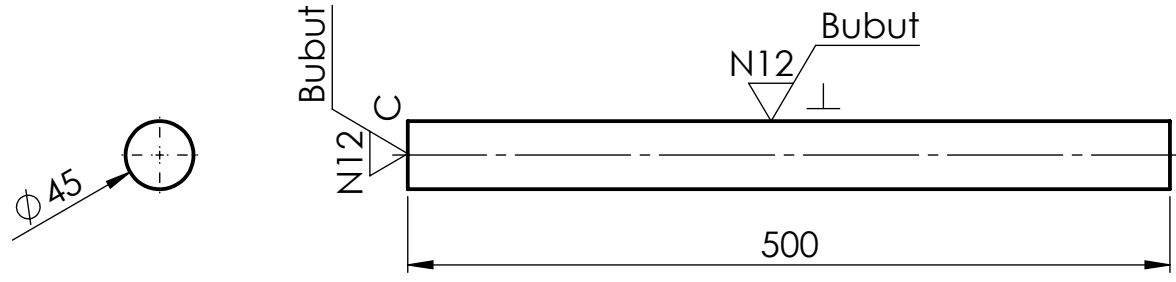
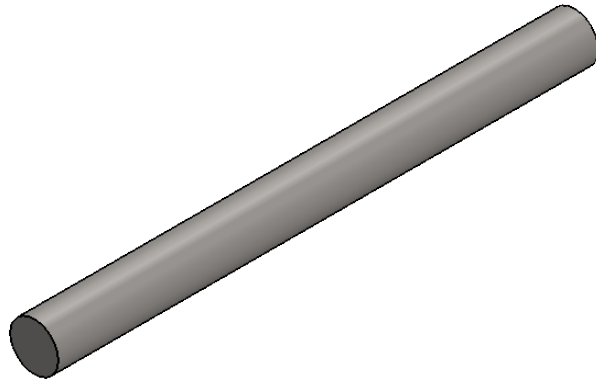

C

C

|     |                |      |      |      |      |       |                    |              |          |            |
|-----|----------------|------|------|------|------|-------|--------------------|--------------|----------|------------|
| 1   | POROS FLYWHEEL |      |      |      |      | S45C  | LIHAT DETAIL       | -            | C2       | -          |
| JML | NAMA BAGIAN    |      |      |      |      | BAHAN | UKURAN JADI        | UKURAN KASAR | NO. ID   | KETERANGAN |
| >   | 0              | 6    | 30   | 120  | 400  | 1000  | Pengerjaan Lanjut: | NO. ORDER    | PROYEKSI |            |
| <   | 6              | 30   | 120  | 400  | 1000 | 2000  |                    |              |          |            |
| Tol | +0.1           | +0.2 | +0.3 | +0.5 | +0.8 | +1.2  |                    |              |          |            |

B

B

A

A

Nama:

# POROS FLYWHEEL

No. Assy:

Skala  
1:10

|           |         |        |
|-----------|---------|--------|
| DIGAMBAR  | 10-4-23 | DITO   |
| DIPERIKSA |         | PUJONO |
| DISAHKAN  |         | PUJONO |



**Politeknik Negeri Cilacap, Jurusan Teknik Mesin**  
 Jl. Dr. Soetomo, No. 01, Sidakaya, Cilacap, 53212  
 Telp: 0282-533329, E-mail: tmpnc@politeknikcilacap.ac.id

FORMAT  
A4

SATUAN  
mm

NO. GAMBAR:  
**NO. 16/TM**

4

3

2

1

PENGGANTI DARI:

DIGANTI DENGAN

DILARANG MENGGANDAKAN, MENYALIN, MEMINDAHKAN GAMBAR INI TANPA IZIN TERTULIS DARI POLITEKNIK NEGERI CILAPAC

DILARANG MENGGANDAKAN, MENYALIN, MEMINDAHTANGKAN GAMBAR INI TANPA IZIN TERTULIS DARI POLITEKNIK NEGERI CILACAP

|     |           |         |      |
|-----|-----------|---------|------|
| 4   | 3         | 2       |      |
| No. | Perubahan | Tanggal | Nama |
| No. | Perubahan | Tanggal | Nama |

F

E

D

C

B

A

F

E

D

C

B

A

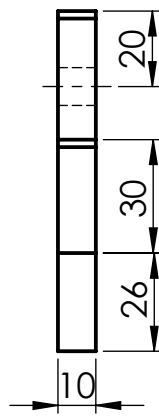
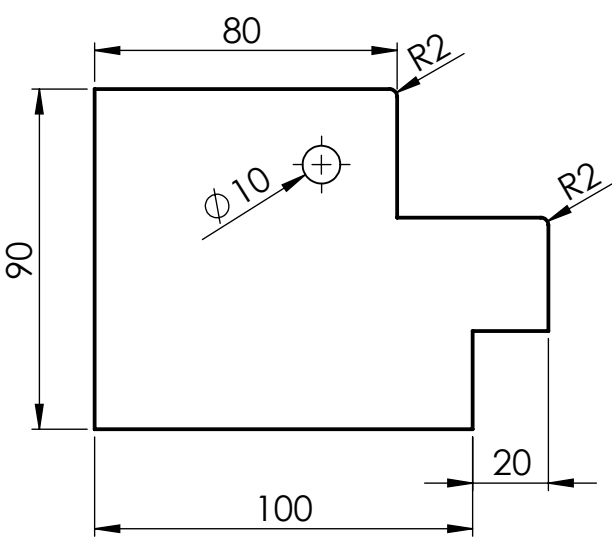
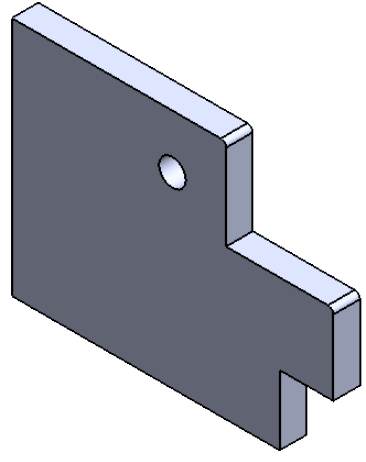
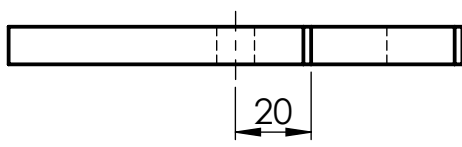

|     |                               |                    |              |              |           |            |
|-----|-------------------------------|--------------------|--------------|--------------|-----------|------------|
| 2   | PENGUNCI PEMOTONG             | SSC                | LIHAT DETAIL | -            | C3        | PRODUKSI   |
| JML | NAMA BAGIAN                   | BAHAN              | UKURAN JADI  | UKURAN KASAR | NO. ID    | KETERANGAN |
| >   | 0 6 30 120 400 1000           | Pengerjaan Lanjut: |              |              | NO. ORDER | PROYEKSI   |
| <   | 6 30 120 400 1000 2000        |                    |              |              |           |            |
| Tol | +0.1 +0.2 +0.3 +0.5 +0.8 +1.2 |                    |              |              |           |            |

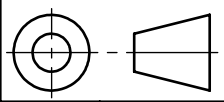

|                          |                         |           |         |        |
|--------------------------|-------------------------|-----------|---------|--------|
| Nama:                    | <b>Skala</b><br><br>1:2 | DIGAMBAR  | 10-4-23 | DITO   |
| <b>PENGUNCI PEMOTONG</b> |                         | DIPERIKSA |         | PUJONO |
|                          |                         | DISAHKAN  |         | PUJONO |
| No. Assy:                |                         |           |         |        |

|   |        |        |                  |
|---|--------|--------|------------------|
| <b>Politeknik Negeri Cilacap, Jurusan Teknik Mesin</b><br>Jl. Dr. Soetomo, No. 01, Sidakaya, Cilacap, 53212<br>Telp: 0282-533329, E-mail: tmpnc@politeknikcilacap.ac.id | FORMAT | SATUAN | NO. GAMBAR:      |
|   | A4     | mm     | <b>NO. 17/TM</b> |

4

3

2

| No. | Perubahan | Tanggal | Nama | No. | Perubahan | Tanggal | Nama |
|-----|-----------|---------|------|-----|-----------|---------|------|
| △   |           |         |      | △   |           |         |      |

F

F

E

E

D

D

C

C

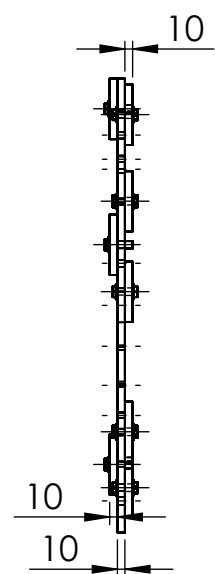
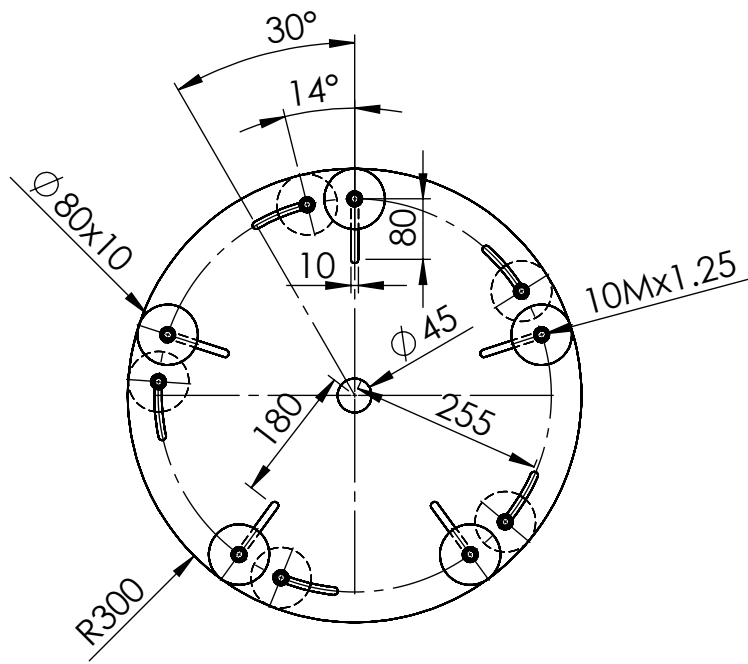
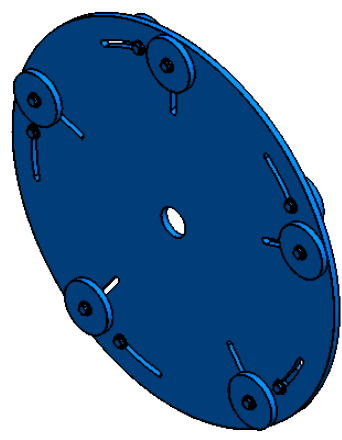

|     |             |      |      |      |      |       |                    |              |           |            |
|-----|-------------|------|------|------|------|-------|--------------------|--------------|-----------|------------|
| 1   | FLYWHEEL    |      |      |      |      | SSC   | LIHAT DETAIL       | -            | C4        | PRODUKSI   |
| JML | NAMA BAGIAN |      |      |      |      | BAHAN | UKURAN JADI        | UKURAN KASAR | NO. ID    | KETERANGAN |
| >   | 0           | 6    | 30   | 120  | 400  | 1000  | Pengerjaan Lanjut: |              | NO. ORDER | PROYEKSI   |
| <   | 6           | 30   | 120  | 400  | 1000 | 2000  |                    |              |           |            |
| Tol | +0.1        | +0.2 | +0.3 | +0.5 | +0.8 | +1.2  |                    |              |           |            |

|       |                 |               |           |         |        |
|-------|-----------------|---------------|-----------|---------|--------|
| Nama: | <b>FLYWHEEL</b> | Skala<br>1:10 | DIGAMBAR  | 10-4-23 | DITO   |
|       |                 |               | DIPERIKSA |         | PUJONO |
|       |                 |               | DISAHKAN  |         | PUJONO |

|   |        |        |                  |
|---|--------|--------|------------------|
| <b>Politeknik Negeri Cilacap, Jurusan Teknik Mesin</b><br>Jl. Dr. Soetomo, No. 01, Sidakaya, Cilacap, 53212<br>Telp: 0282-533329, E-mail: tmpnc@politeknikcilacap.ac.id | FORMAT | SATUAN | NO. GAMBAR:      |
|   | A4     | mm     | <b>NO. 18/TM</b> |

DILARANG MENGGANDAKAN, MENYALIN, MEMINDAHTANGKAN GAMBAR INI TANPA IZIN TERTULIS DARI POLITEKNIK NEGERI CILACAP

PENGGANTI DARI:

DIGANTI DENGAN:

4

3

2

1

A

A

|     |           |         |      |
|-----|-----------|---------|------|
| 4   | 3         | 2       |      |
| No. | Perubahan | Tanggal | Nama |
| No. | Perubahan | Tanggal | Nama |

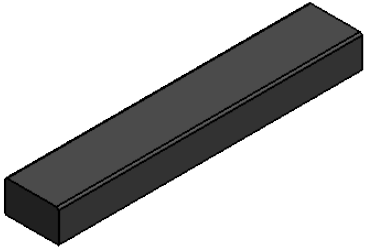

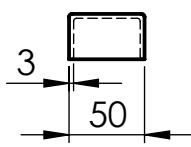

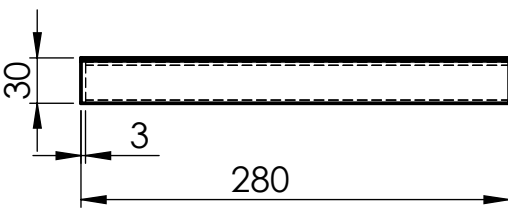

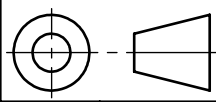
|            |   |              |                    |                     |               |   |
|------------|---|--------------|--------------------|---------------------|---------------|---|
| 1          | PENAHAN DUDUKAN PEMOTONG                | UNP          | LIHAT DETAIL       | -                   | C5            | PRODUKSI  |
| <b>JML</b> | <b>NAMA BAGIAN</b>                      | <b>BAHAN</b> | <b>UKURAN JADI</b> | <b>UKURAN KASAR</b> | <b>NO. ID</b> | <b>KETERANGAN</b>   |
| >          | 0    6    30    120    400              | 1000         | Pengerjaan Lanjut: |                     | NO. ORDER     | PROYEKSI  |
| <          | 6    30    120    400    1000           | 2000         |                    |                     |               |   |
| Tol        | ±0.1   ±0.2   ±0.3   ±0.5   ±0.8   ±1.2 |              |                    |                     |               |  |

|  |                         |                                   |   |  |
|--|-------------------------|-----------------------------------|---|--|
| Nama:<br><br><h2 style="text-align: center;">PENAHAN DUDUKAN PEMOTONG</h2> No. Assy: | <b>Skala</b><br><br>1:5 | DIGAMBAR<br>DIPERIKSA<br>DISAHKAN | 10-4-23<br><br><br>PUJONO<br><br>PUJONO |  |
|--|-------------------------|-----------------------------------|---|--|

|   |   |                     |                     |  |
|---|---|---------------------|---------------------|--|
|  | <b>Politeknik Negeri Cilacap, Jurusan Teknik Mesin</b><br>Jl. Dr. Soetomo, No. 01, Sidakaya, Cilacap, 53212<br>Telp: 0282-533329, E-mail: tmpnc@politeknikcilacap.ac.id | <b>FORMAT</b><br>A4 | <b>SATUAN</b><br>mm | <b>NO. GAMBAR:</b><br><b>NO. 19/TM</b> |
|---|---|---------------------|---------------------|--|

|                |                |   |  |
|----------------|----------------|---|--|
| 4              | 3              | 2 |  |
| PENGANTI DARI: | DIGANTI DENGAN |   |  |

4

3

2

|     |           |         |      |     |           |         |      |
|-----|-----------|---------|------|-----|-----------|---------|------|
| No. | Perubahan | Tanggal | Nama | No. | Perubahan | Tanggal | Nama |
| △   |           |         |      | △   |           |         |      |

F

F

E

E

D

D

C

C

B

B

A

A

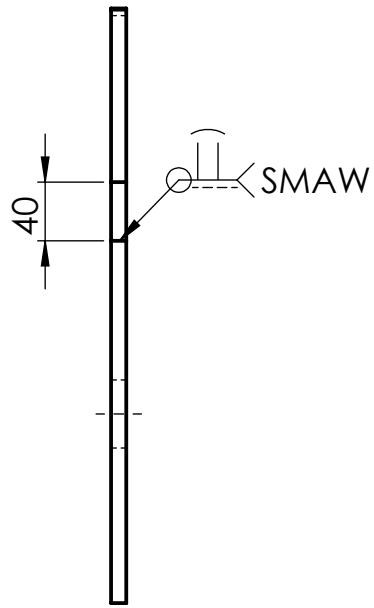
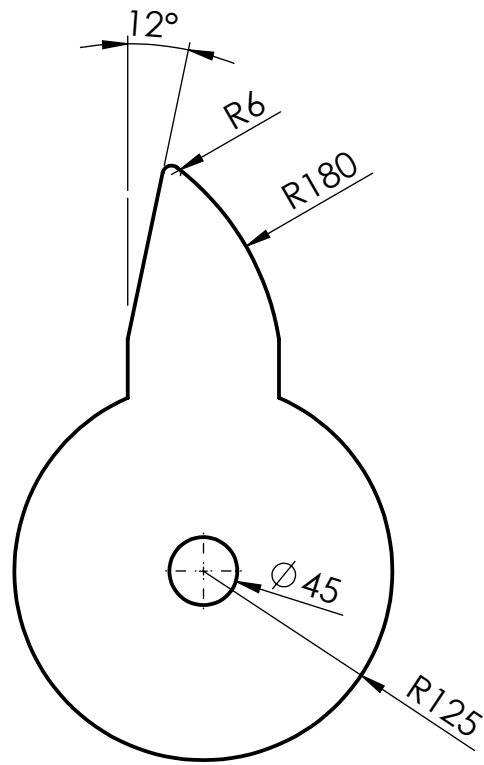
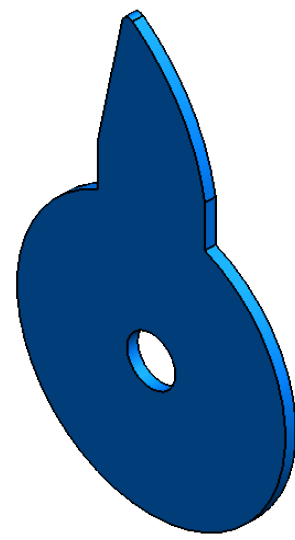
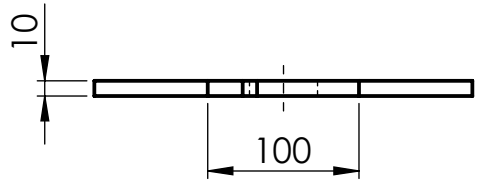

|     |                   |      |      |      |      |       |                    |              |           |            |
|-----|-------------------|------|------|------|------|-------|--------------------|--------------|-----------|------------|
| 1   | FLYWHEEL PEMOTONG |      |      |      |      | SSC   | LIHAT DETAIL       | -            | C6        | PRODUKSI   |
| JML | NAMA BAGIAN       |      |      |      |      | BAHAN | UKURAN JADI        | UKURAN KASAR | NO. ID    | KETERANGAN |
| >   | 0                 | 6    | 30   | 120  | 400  | 1000  | Pengerjaan Lanjut: |              | NO. ORDER | PROYEKSI   |
| <   | 6                 | 30   | 120  | 400  | 1000 | 2000  |                    |              |           |            |
| Tol | +0.1              | +0.2 | +0.3 | +0.5 | +0.8 | +1.2  |                    |              |           |            |

|           |                          |              |           |         |        |
|-----------|--------------------------|--------------|-----------|---------|--------|
| Nama:     | <b>FLYWHEEL PEMOTONG</b> | Skala<br>1:5 | DIGAMBAR  | 10-4-23 | DITO   |
|           |                          |              | DIPERIKSA |         | PUJONO |
|           |                          |              | DISAHKAN  |         | PUJONO |
| No. Assy: |                          |              |           |         |        |

|   |        |        |                  |
|---|--------|--------|------------------|
| <b>Politeknik Negeri Cilacap, Jurusan Teknik Mesin</b><br>Jl. Dr. Soetomo, No. 01, Sidakaya, Cilacap, 53212<br>Telp: 0282-533329, E-mail: tmpnc@politeknikcilacap.ac.id | FORMAT | SATUAN | NO. GAMBAR:      |
|   | A4     | mm     | <b>NO. 20/TM</b> |

DILARANG MENGGANDAKAN, MENYALIN, MEMINDAHTANGKAN GAMBAR INI TANPA IZIN TERTULIS DARI POLITEKNIK NEGERI CILACAP

PENGGANTI DARI:

DIGANTI DENGAN:

4

3

2

1

|     |           |         |      |
|-----|-----------|---------|------|
| 4   | 3         | 2       |      |
| No. | Perubahan | Tanggal | Nama |
| No. | Perubahan | Tanggal | Nama |

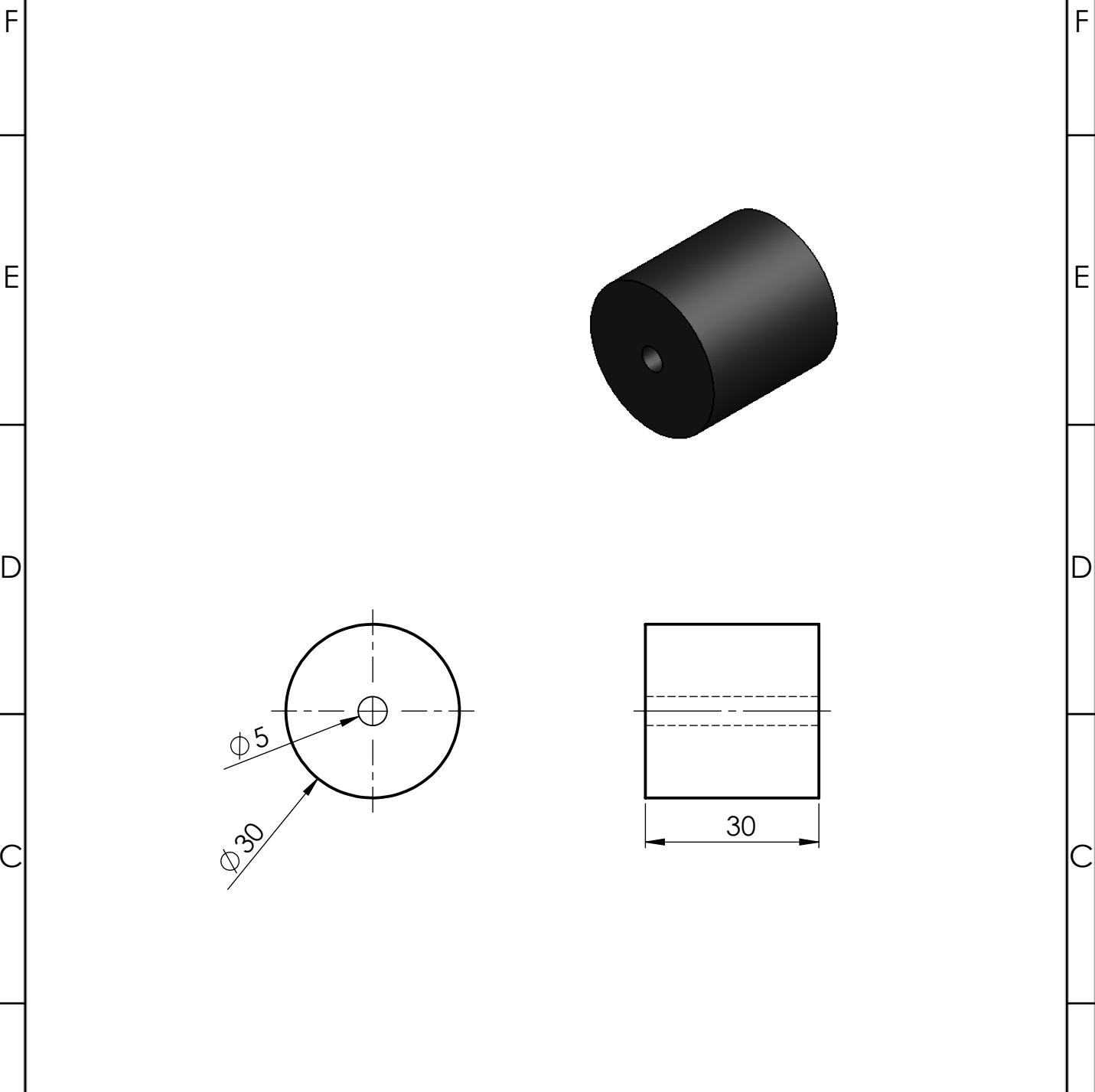

|            |                    |              |                    |                     |               |                   |
|------------|--------------------|--------------|--------------------|---------------------|---------------|-------------------|
| 1          | PEREDAM SUARA      | RUBBER       | LIHAT DETAIL       | -                   | C8            | PRODUKSI          |
| <b>JML</b> | <b>NAMA BAGIAN</b> | <b>BAHAN</b> | <b>UKURAN JADI</b> | <b>UKURAN KASAR</b> | <b>NO. ID</b> | <b>KETERANGAN</b> |
| >          | 0                  | 6            | 30                 | 120                 | 400           | 1000              |
| <          | 6                  | 30           | 120                | 400                 | 1000          | 2000              |
| Tol        | +0.1               | +0.2         | +0.3               | +0.5                | +0.8          | +1.2              |

|   |                         |                                   |   |   |
|---|-------------------------|-----------------------------------|---|---|
| Nama:<br><br><h2 style="text-align: center;">PEREDAM SUARA</h2><br>No. Assy:  | <b>Skala</b><br><br>1:1 | DIGAMBAR<br>DIPERIKSA<br>DISAHKAN | 10-4-23<br><br><br>DITO<br>PUJONO<br>PUJONO | PROYEKSI<br> |
|  <b>Politeknik Negeri Cilacap, Jurusan Teknik Mesin</b><br>Jl. Dr. Soetomo, No. 01, Sidakaya, Cilacap, 53212<br>Telp: 0282-533329, E-mail: tmpnc@politeknikcilacap.ac.id | <b>FORMAT</b><br>A4     | <b>SATUAN</b><br>mm               | <b>NO. GAMBAR:</b><br><b>NO. 21/TM</b>      |   |