

LAMPIRAN 1
BIODATA PENULIS

BIODATA PENULIS



Nama : Fajar Subhekti
Tempat/Tanggal Lahir : Cilacap, 14 Februari 2001
Alamat : Jalan Salam 1 Rt02/Rw06 Tritih Kulon Cilacap utara, Cilacap, Jawa Tengah
Email : fajarsubhekti02@gmail.com
Telfon/HP : 085641524917
Hobi : Traveling dan swim
Motto : “Saya tidak percaya pada keberuntungan karena keberuntungan adalah ketika kesempatan bertemu dengan kemampuan. Kemampuan bisa diasah, kesempatan bisa dicari.”

Riwayat Pendidikan

- SD Negeri 06 Tritih Kulon : Tahun 2007 - 2013
- SMP Negeri 5 Cilacap : Tahun 2013 - 2016
- SMK Negeri 2 Cilacap : Tahun 2016 - 2019
- Politeknik Negeri Cilacap : Tahun 2019 – 2023



Penulis telah mengikuti Sidang Tugas Akhir pada tanggal 09 Juni 2023. Sebagai salah satu persyaratan untuk memperoleh gelar Ahli Madya (A.md.).

Saya yang bersangkutan.

(Fajar Subhekti)

LAMPIRAN 2
DETAIL GAMBAR *PART*

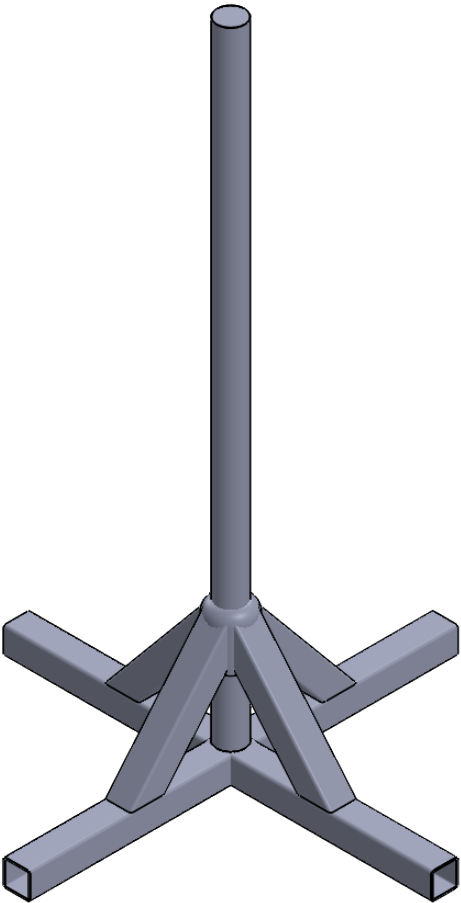
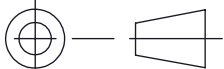
5		4			3		2		1	
NO	PERUBAHAN			TANGGAL	NAMA	NO	PERUBAHAN		TANGGAL	NAMA
						∇				
1	Mal Lingkaran								A13	
9	Mur M10 x 1,5								A12	
1	Baut M10 x 1,5 x 45								A11	
1	Baut M10 x 1,5 x 60								A10	
1	Penahan								A9	
5	Baut M10 x1,5 x50								A8	
1	Jarum Mal								A7	
2	Pin								A6	
1	Tempat Mal								A5	
1	Lengan Utama								A4	
1	Lengan Kedua								A3	
1	Lengan Penyangga								A2	
1	Tiang								A1	
JML	NAMA BAGIAN			POS	BAHAN	UKURAN JADI	UKURAN KASAR	NO. ID	F	
>	0	6	30	120	400	1000	UKURAN LANJUT	NO. ORDER	PROYEKSI	
<	6	30	120	400	1000	2000				
TOL	±0.1	±0.2	±0.3	±0.5	±0.8	±1.2				
NAMA :							SKALA	DIGAMBAR	20-06-2022	FAJAR
<h1>Assembly</h1>							1:10	DIPERIKSA		DIAN
								DISAHKAN		
NO. ASSY. :							FORMAT	SATUAN		
POLITEKNIK NEGERI CILACAP, JURUSAN TEKNIK MESIN JL. dr. SOETOMO, NO. 01, SIDAKAYA, CILACAP, 53212 TELP : 0282 - 533329, E-mail :tmpnc@politeknikcilacap.ac.id							A4	mm	NO : 01/TM	
5		4			3		2		1	
PERUBAHAN DARI :					DIGANTI DENGAN :					

5		4			3		2		1		
NO	PERUBAHAN	TANGGAL	NAMA	NO	PERUBAHAN	TANGGAL	NAMA				
				/							
E											E
D											D
C											C
B											B
I	Tiang								A1		
JML	NAMA BAGIAN					POS	BAHAN	UKURAN JADI	UKURAN KASAR	NO. ID	F
>	0	6	30	120	400	1000	UKURAN LANJUT		NO. ORDER	PROYEKSI	
<	6	30	120	400	1000	2000					
TOL	±0.1	±0.2	±0.3	±0.5	±0.8	±1.2					
A	NAMA : <h2 style="text-align: center;">Tiang</h2>							SKALA	DIGAMBAR	20-06-2022	FAJAR
								1:10	DIPERIKSA		
									DISAHKAN		
	NO. ASSY. :										
	 POLITEKNIK NEGERI CILACAP, JURUSAN TEKNIK MESIN JL. dr. SOETOMO, NO. 01, SIDAKAYA, CILACAP, 53212 TELP : 0282 - 533329, E-mail :tmpnc@politeknikcilacap.ac.id							FORMAT	SATUAN	NO : 02/TM	
								A4	mm		
5		4			3		2		1		
PERUBAHAN DARI :							DIGANTI DENGAN :				

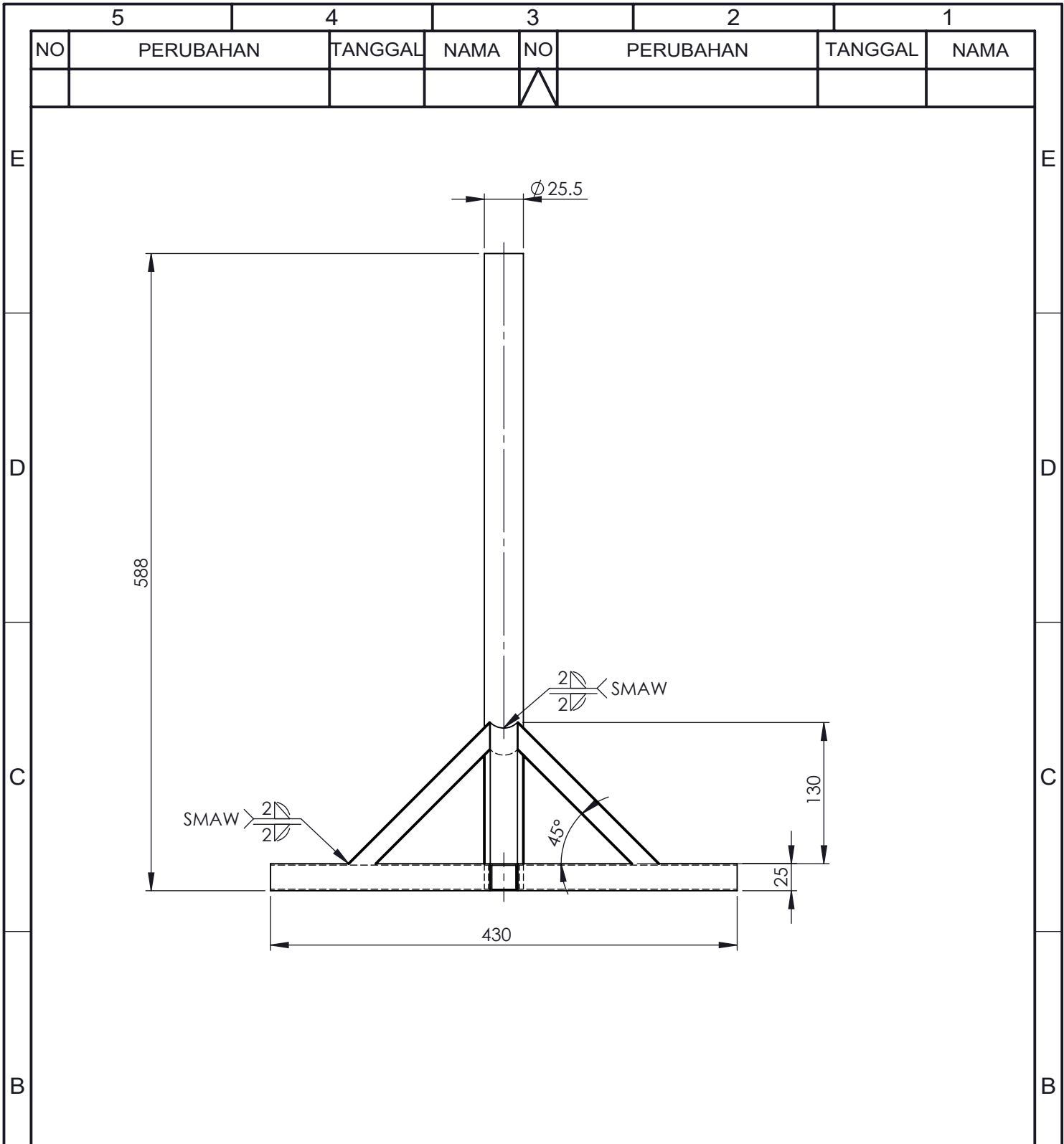



I	Tiang									A1	
JML	NAMA BAGIAN					POS	BAHAN	UKURAN JADI	UKURAN KASAR	NO. ID	F
>	0	6	30	120	400	1000	UKURAN LANJUT	NO. ORDER	PROYEKSI		
<	6	30	120	400	1000	2000					
TOL	±0.1	±0.2	±0.3	±0.5	±0.8	±1.2					
NAMA :								SKALA	DIGAMBAR	20-06-2022	FAJAR
Tiang Pandangan Depan								1:10	DIPERIKSA		
									DISAHKAN		
NO. ASSY. :								FORMAT	SATUAN		
POLITEKNIK NEGERI CILACAP, JURUSAN TEKNIK MESIN JL. dr. SOETOMO, NO. 01, SIDAKAYA, CILACAP, 53212 TELP : 0282 - 533329, E-mail :tmpnc@politeknikcilacap.ac.id								A4	mm	NO : 02/TM	

		5		4		3		2		1		
NO	PERUBAHAN			TANGGAL	NAMA	NO	PERUBAHAN			TANGGAL	NAMA	
						∇						
E												E
D												D
C												C
B												B
I	Tiang										A1	
JML	NAMA BAGIAN					POS	BAHAN	UKURAN JADI	UKURAN KASAR	NO. ID	F	
>	0	6	30	120	400	1000	UKURAN LANJUT		NO. ORDER	PROYEKSI		
<	6	30	120	400	1000	2000						
TOL	±0.1	±0.2	±0.3	±0.5	±0.8	±1.2						
NAMA :								SKALA	DIGAMBAR	20-06-2022	FAJAR	
<h1>Tiang Pandangan Atas</h1>								1:10	DIPERIKSA			
									DISAHKAN			
NO. ASSY. :								FORMAT	SATUAN			
POLITEKNIK NEGERI CILACAP, JURUSAN TEKNIK MESIN JL. dr. SOETOMO, NO. 01, SIDAKAYA, CILACAP, 53212 TELP : 0282 - 533329, E-mail :tmpnc@politeknikcilacap.ac.id								A4	mm	NO : 02/TM		
		5		4		3		2		1		
PERUBAHAN DARI :						DIGANTI DENGAN :						

5		4			3		2		1	
NO	PERUBAHAN	TANGGAL	NAMA	NO	PERUBAHAN	TANGGAL	NAMA			
				/						

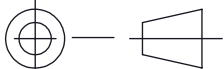

1	Penyangga Lengan											A2	
JML	NAMA BAGIAN					POS	BAHAN	UKURAN JADI	UKURAN KASAR	NO. ID	F		
>	0	6	30	120	400	1000	UKURAN LANJUT		NO. ORDER		PROYEKSI		
<	6	30	120	400	1000	2000							
TOL	±0.1	±0.2	±0.3	±0.5	±0.8	±1.2							
NAMA :								SKALA	DIGAMBAR	20-06-2022	FAJAR		
Penyangga Lengan								1:2	DIPERIKSA				
NO. ASSY. :									DISAHKAN				
 POLITEKNIK NEGERI CILACAP, JURUSAN TEKNIK MESIN JL. dr. SOETOMO, NO. 01, SIDAKAYA, CILACAP, 53212 TELP : 0282 - 533329, E-mail :tmpnc@politeknikcilacap.ac.id								FORMAT	SATUAN	NO : 03/TM			
								A4	mm				

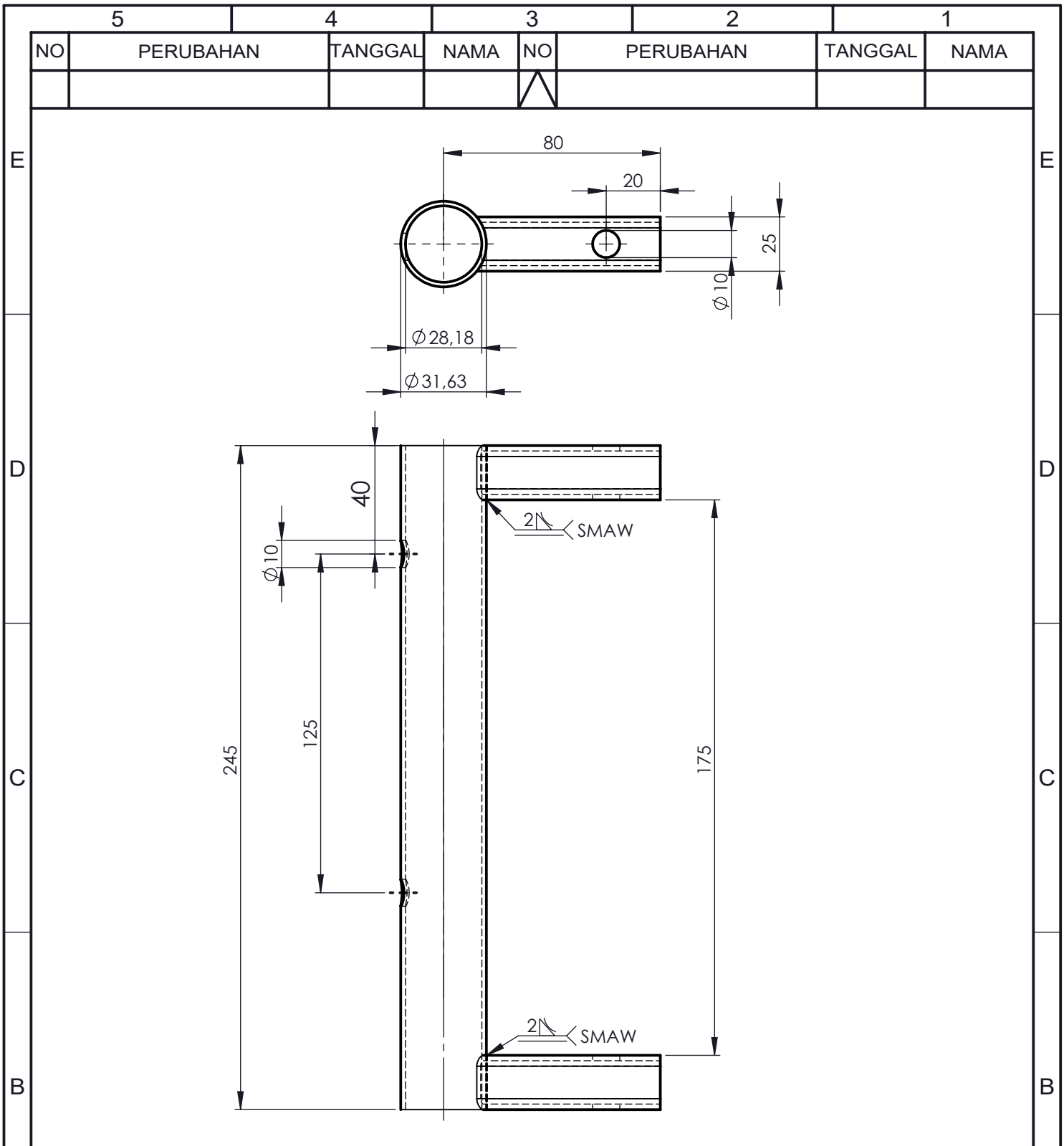

5	4	3	2	1
PERUBAHAN DARI :	DIGANTI DENGAN :			



1	Penyangga Lengan						A2					
JML	NAMA BAGIAN					POS	BAHAN	UKURAN JADI	UKURAN KASAR	NO. ID	F	
>	0	6	30	120	400	1000	UKURAN LANJUT		NO. ORDER	PROYEKSI		
<	6	30	120	400	1000	2000						
TOL	±0.1	±0.2	±0.3	±0.5	±0.8	±1.2						
NAMA :									SKALA	DIGAMBAR	20-06-2022	FAJAR
<h1>Penyangga Lengan</h1>									1:2	DIPERIKSA		
										DISAHKAN		
NO. ASSY. :									FORMAT	SATUAN		
POLITEKNIK NEGERI CILACAP, JURUSAN TEKNIK MESIN JL. dr. SOETOMO, NO. 01, SIDAKAYA, CILACAP, 53212 TELP : 0282 - 533329, E-mail : tmpnc@politeknikcilacap.ac.id									A4	mm	NO : 03/TM	

PERUBAHAN DARI :

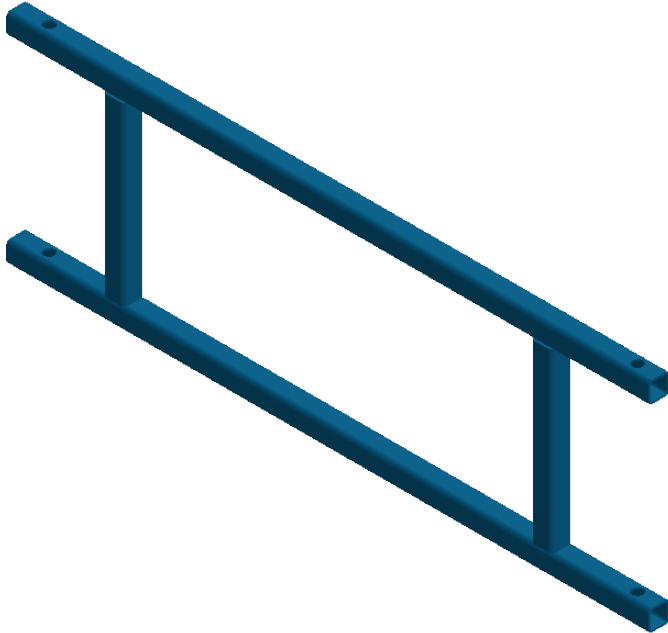
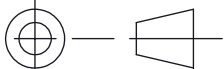
DIGANTI DENGAN :

5		4			3		2		1		
NO	PERUBAHAN	TANGGAL	NAMA	NO	PERUBAHAN	TANGGAL	NAMA				
				/							
E											E
D											D
C											C
B											B
1	Lengan Kedua								A3		
JML	NAMA BAGIAN					POS	BAHAN	UKURAN JADI	UKURAN KASAR	NO. ID	F
>	0	6	30	120	400	1000	UKURAN LANJUT		NO. ORDER	PROYEKSI 	
<	6	30	120	400	1000	2000					
TOL	±0.1	±0.2	±0.3	±0.5	±0.8	±1.2					
NAMA :								SKALA	DIGAMBAR	20-06-2022	FAJAR
<h1>Lengan Kedua</h1>								1:5	DIPERIKSA		
NO. ASSY. :									DISAHKAN		
 POLITEKNIK NEGERI CILACAP, JURUSAN TEKNIK MESIN JL. dr. SOETOMO, NO. 01, SIDAKAYA, CILACAP, 53212 TELP : 0282 - 533329, E-mail :tmpnc@politeknikcilacap.ac.id								FORMAT	SATUAN	NO : 04/TM	
								A4	mm		
5		4			3		2		1		
PERUBAHAN DARI :						DIGANTI DENGAN :					

5		4			3		2		1			
NO	PERUBAHAN			TANGGAL	NAMA	NO	PERUBAHAN		TANGGAL	NAMA		
						∇						
1	Lengan Kedua									A3		
JML	NAMA BAGIAN					POS	BAHAN	UKURAN JADI	UKURAN KASAR	NO. ID	F	
>	0	6	30	120	400	1000	UKURAN LANJUT		NO. ORDER	PROYEKSI		
<	6	30	120	400	1000	2000						
TOL	±0.1	±0.2	±0.3	±0.5	±0.8	±1.2						
NAMA :								SKALA	DIGAMBAR	20-06-2022	FAJAR	
<h1>Lengan Kedua</h1>								1:5	DIPERIKSA			
									DISAHKAN			
NO. ASSY. :								FORMAT	SATUAN			
POLITEKNIK NEGERI CILACAP, JURUSAN TEKNIK MESIN JL. dr. SOETOMO, NO. 01, SIDAKAYA, CILACAP, 53212 TELP : 0282 - 533329, E-mail : tmpnc@politeknikcilacap.ac.id								A4	mm		NO : 04/TM	
5		4			3		2		1			
PERUBAHAN DARI :						DIGANTI DENGAN :						

	5		4		3		2		1	
NO	PERUBAHAN			TANGGAL	NAMA	NO	PERUBAHAN		TANGGAL	NAMA
						/				

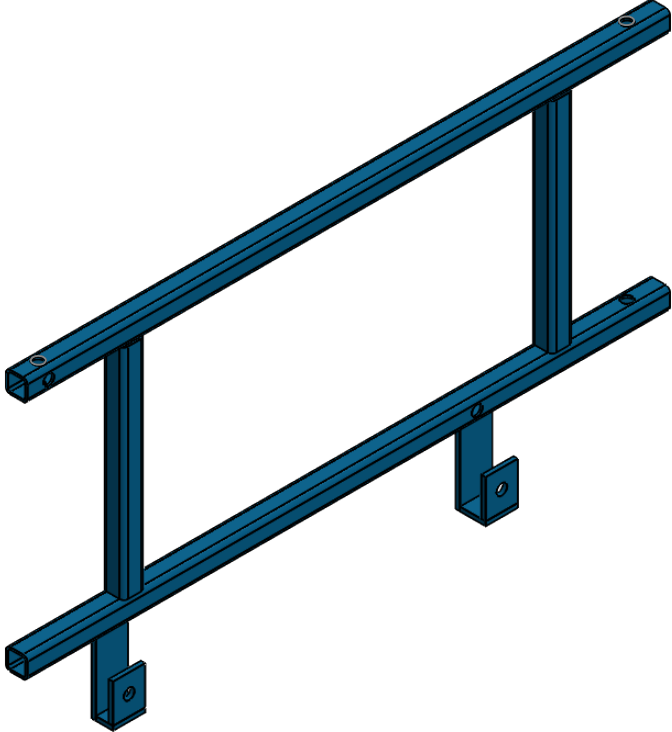

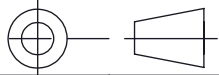
1	Lengan Utama									A4	
JML	NAMA BAGIAN					POS	BAHAN	UKURAN JADI	UKURAN KASAR	NO. ID	F
>	0	6	30	120	400	1000	UKURAN LANJUT		NO. ORDER	PROYEKSI 	
<	6	30	120	400	1000	2000					
TOL	±0.1	±0.2	±0.3	±0.5	±0.8	±1.2					

NAMA : <h2 style="text-align:center;">Lengan Utama</h2>	SKALA <h3 style="text-align:center;">1:5</h3>	DIGAMBAR 20-06-2022	FAJAR	
NO. ASSY. :	DIPERIKSA			
DISAHKAN				

5	4	3	2	1
 POLITEKNIK NEGERI CILACAP, JURUSAN TEKNIK MESIN JL. dr. SOETOMO, NO. 01, SIDAKAYA, CILACAP, 53212 TELP : 0282 - 533329, E-mail :tmpnc@politeknikcilacap.ac.id			FORMAT <h3 style="text-align:center;">A4</h3>	SATUAN mm
			<h2 style="font-size: 2em;">NO : 05/TM</h2>	

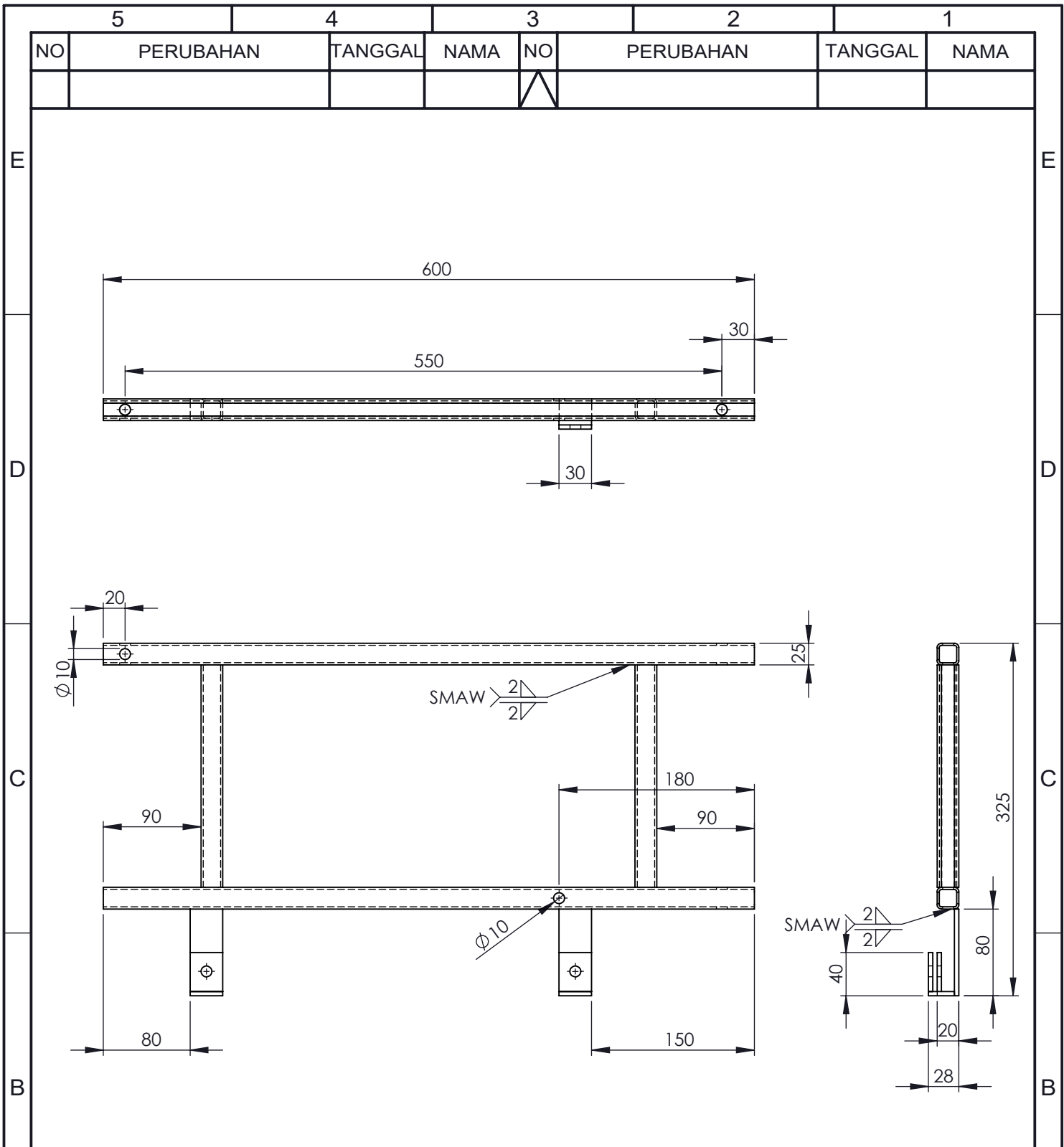

PERUBAHAN DARI :	DIGANTI DENGAN :
------------------	------------------



I	Lengan Utama										A4	
JML	NAMA BAGIAN					POS	BAHAN	UKURAN JADI	UKURAN KASAR	NO. ID	F	
>	0	6	30	120	400	1000	UKURAN LANJUT	NO. ORDER	PROYEKSI			
<	6	30	120	400	1000	2000						
TOL	±0.1	±0.2	±0.3	±0.5	±0.8	±1.2						
NAMA :								SKALA	DIGAMBAR	20-06-2022	FAJAR	
<h1>Lengan Utama</h1>								1:10	DIPERIKSA			
									DISAHKAN			
NO. ASSY. :								FORMAT	SATUAN			
POLITEKNIK NEGERI CILACAP, JURUSAN TEKNIK MESIN JL. dr. SOETOMO, NO. 01, SIDAKAYA, CILACAP, 53212 TELP : 0282 - 533329, E-mail :tmpnc@politeknikcilacap.ac.id								A4	mm	<h2>NO : 05/TM</h2>		

PERUBAHAN DARI :

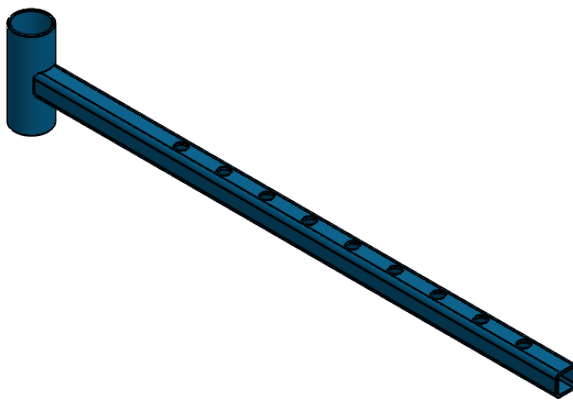
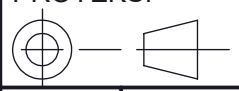
DIGANTI DENGAN :

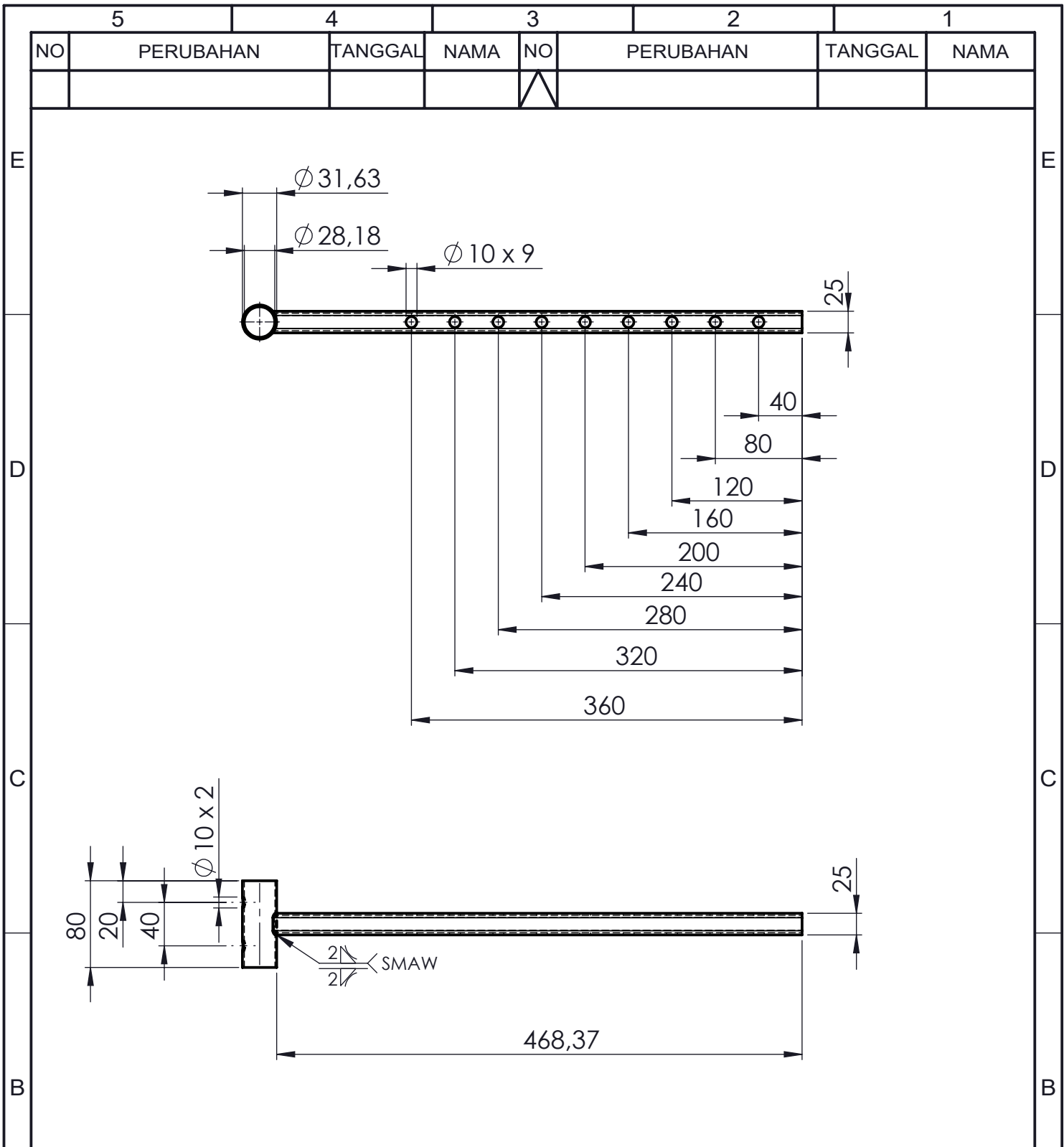

5		4			3		2		1		
NO	PERUBAHAN	TANGGAL	NAMA	NO	PERUBAHAN	TANGGAL	NAMA				
				/							
E											E
D											D
C											C
B											B
A											A
1	Tempat Mal								A5		
JML	NAMA BAGIAN					POS	BAHAN	UKURAN JADI	UKURAN KASAR	NO. ID	F
>	0	6	30	120	400	1000	UKURAN LANJUT		NO. ORDER	PROYEKSI	
<	6	30	120	400	1000	2000					
TOL	±0.1	±0.2	±0.3	±0.5	±0.8	±1.2					
NAMA :								SKALA	DIGAMBAR	20-06-2022	FAJAR
<h1>Tempat Mal</h1>								1:5	DIPERIKSA		
NO. ASSY. :									DISAHKAN		
 POLITEKNIK NEGERI CILACAP, JURUSAN TEKNIK MESIN JL. dr. SOETOMO, NO. 01, SIDAKAYA, CILACAP, 53212 TELP : 0282 - 533329, E-mail :tmpnc@politeknikcilacap.ac.id								FORMAT	SATUAN	NO : 06/TM	
								A4	mm		
5		4			3		2		1		
PERUBAHAN DARI :						DIGANTI DENGAN :					



1	Tempat Mal								A5		
JML	NAMA BAGIAN					POS	BAHAN	UKURAN JADI	UKURAN KASAR	NO. ID	F
>	0	6	30	120	400	1000	UKURAN LANJUT		NO. ORDER	PROYEKSI	
<	6	30	120	400	1000	2000					
TOL	± 0.1	± 0.2	± 0.3	± 0.5	± 0.8	± 1.2					
NAMA :								SKALA	DIGAMBAR	20-06-2022	FAJAR
<h1>Tempat Mal</h1>								1:5	DIPERIKSA		
									DISAHKAN		
NO. ASSY. :								FORMAT	SATUAN		
POLITEKNIK NEGERI CILACAP, JURUSAN TEKNIK MESIN JL. dr. SOETOMO, NO. 01, SIDAKAYA, CILACAP, 53212 TELP : 0282 - 533329, E-mail : tmpnc@politeknikcilacap.ac.id								A4	mm	NO : 06/TM	

PERUBAHAN DARI :

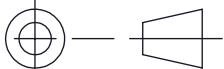
DIGANTI DENGAN :

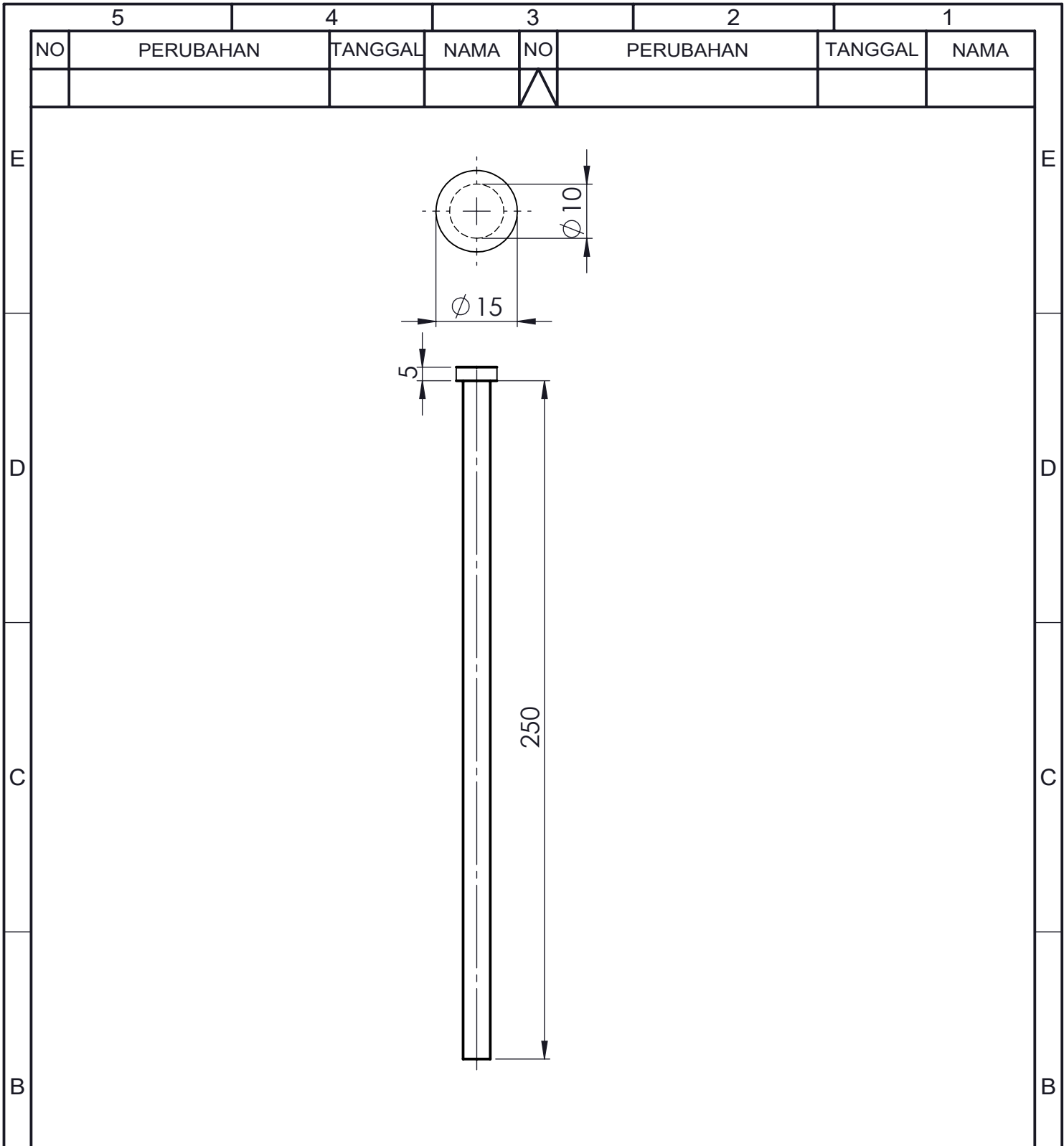

		5		4		3		2		1	
NO	PERUBAHAN	TANGGAL	NAMA	NO	PERUBAHAN	TANGGAL	NAMA				
				/							
E											E
D											D
C											C
B											B
1	Pin									A6	
JML	NAMA BAGIAN					POS	BAHAN	UKURAN JADI	UKURAN KASAR	NO. ID	F
>	0	6	30	120	400	1000	UKURAN LANJUT		NO. ORDER	PROYEKSI 	
<	6	30	120	400	1000	2000					
TOL	±0.1	±0.2	±0.3	±0.5	±0.8	±1.2					
NAMA :								SKALA	DIGAMBAR	20-06-2022	FAJAR
<h1>Pin</h1>								1:2	DIPERIKSA		
									DISAHKAN		
NO. ASSY. :								FORMAT	SATUAN	NO : 07/TM	
 POLITEKNIK NEGERI CILACAP, JURUSAN TEKNIK MESIN JL. dr. SOETOMO, NO. 01, SIDAKAYA, CILACAP, 53212 TELP : 0282 - 533329, E-mail :tmpnc@politeknikcilacap.ac.id								A4	mm		
		5		4		3		2		1	
PERUBAHAN DARI :						DIGANTI DENGAN :					



1	Pin								A6			
JML	NAMA BAGIAN	POS	BAHAN	UKURAN JADI	UKURAN KASAR	NO. ID	F					
>	0	6	30	120	400	1000	UKURAN LANJUT		NO. ORDER	PROYEKSI		
<	6	30	120	400	1000	2000						
TOL	±0.1	±0.2	±0.3	±0.5	±0.8	±1.2						
NAMA :									SKALA	DIGAMBAR	20-06-2022	FAJAR
<h1>Pin</h1>									<h1>1:2</h1>	DIPERIKSA		
										DISAHKAN		
NO. ASSY. :									FORMAT	SATUAN		
POLITEKNIK NEGERI CILACAP, JURUSAN TEKNIK MESIN JL. dr. SOETOMO, NO. 01, SIDAKAYA, CILACAP, 53212 TELP : 0282 - 533329, E-mail :tmpnc@politeknikcilacap.ac.id									<h1>A4</h1>	mm	<h1>NO : 07/TM</h1>	

PERUBAHAN DARI :

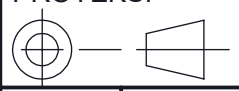
DIGANTI DENGAN :

5		4			3		2		1		
NO	PERUBAHAN	TANGGAL	NAMA	NO	PERUBAHAN	TANGGAL	NAMA				
				/							
											
1	Jarum Mal								A7		
JML	NAMA BAGIAN					POS	BAHAN	UKURAN JADI	UKURAN KASAR	NO. ID	F
>	0	6	30	120	400	1000	UKURAN LANJUT		NO. ORDER	PROYEKSI 	
<	6	30	120	400	1000	2000					
TOL	±0.1	±0.2	±0.3	±0.5	±0.8	±1.2					
NAMA :								SKALA	DIGAMBAR	20-06-2022	FAJAR
Jarum Mal								2:1	DIPERIKSA		
NO. ASSY. :									DISAHKAN		
 POLITEKNIK NEGERI CILACAP, JURUSAN TEKNIK MESIN JL. dr. SOETOMO, NO. 01, SIDAKAYA, CILACAP, 53212 TELP : 0282 - 533329, E-mail :tmpnc@politeknikcilacap.ac.id								FORMAT	SATUAN		
								A4	mm		
5		4			3		2		1		
PERUBAHAN DARI :						DIGANTI DENGAN :					



	5		4		3		2		1	
NO	PERUBAHAN			TANGGAL	NAMA	NO	PERUBAHAN		TANGGAL	NAMA
						/				

1	Jarum Mal											A7	
JML	NAMA BAGIAN					POS	BAHAN	UKURAN JADI		UKURAN KASAR		NO. ID	F
>	0	6	30	120	400	1000	UKURAN LANJUT		NO. ORDER		PROYEKSI		
<	6	30	120	400	1000	2000							
TOL	±0.1	±0.2	±0.3	±0.5	±0.8	±1.2							

NAMA : <h2 style="text-align: center;">Jarum Mal</h2>	SKALA <h2 style="text-align: center;">2:1</h2>	DIGAMBAR 20-06-2022 FAJAR DIPERIKSA DISAHKAN		
NO. ASSY. :	FORMAT A4	SATUAN mm		

POLITEKNIK NEGERI CILACAP, JURUSAN TEKNIK MESIN
 JL. dr. SOETOMO, NO. 01, SIDAKAYA, CILACAP, 53212
 TELP : 0282 - 533329, E-mail :tmpnc@politeknikcilacap.ac.id

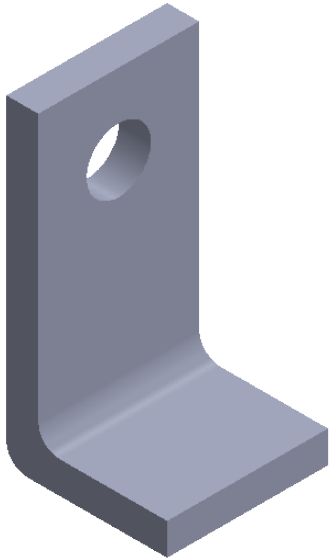
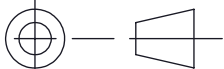
	5		4		3		2		1
PERUBAHAN DARI :					DIGANTI DENGAN :				



5		4			3		2		1		
NO	PERUBAHAN	TANGGAL	NAMA	NO	PERUBAHAN	TANGGAL	NAMA				
				/							
											
1	Penahan								A9		
JML	NAMA BAGIAN					POS	BAHAN	UKURAN JADI	UKURAN KASAR	NO. ID	F
>	0	6	30	120	400	1000	UKURAN LANJUT		NO. ORDER	PROYEKSI	
<	6	30	120	400	1000	2000					
TOL	±0.1	±0.2	±0.3	±0.5	±0.8	±1.2					
NAMA :								SKALA	DIGAMBAR	20-06-2022	FAJAR
Penahan								2:1	DIPERIKSA		
NO. ASSY. :									DISAHKAN		
 POLITEKNIK NEGERI CILACAP, JURUSAN TEKNIK MESIN JL. dr. SOETOMO, NO. 01, SIDAKAYA, CILACAP, 53212 TELP : 0282 - 533329, E-mail :tmpnc@politeknikcilacap.ac.id								FORMAT	SATUAN		
								A4	mm	NO : 10/TM	
5		4			3		2		1		
PERUBAHAN DARI :						DIGANTI DENGAN :					

5	4	3	2	1			
NO	PERUBAHAN	TANGGAL	NAMA	NO	PERUBAHAN	TANGGAL	NAMA
				/			

1	Penahan						A9
JML	NAMA BAGIAN	POS	BAHAN	UKURAN JADI	UKURAN KASAR	NO. ID	F
>	0	6	30	120	400	1000	
<	6	30	120	400	1000	2000	
TOL	±0.1	±0.2	±0.3	±0.5	±0.8	±1.2	

NAMA : <h2 style="text-align: center;">Penahan</h2>	SKALA <h2 style="text-align: center;">2:1</h2>	DIGAMBAR 20-06-2022	FAJAR	DIPERIKSA DISAHKAN
NO. ASSY. :	FORMAT <h2 style="text-align: center;">A4</h2>	SATUAN mm	<h2 style="text-align: center;">NO : 10/TM</h2>	

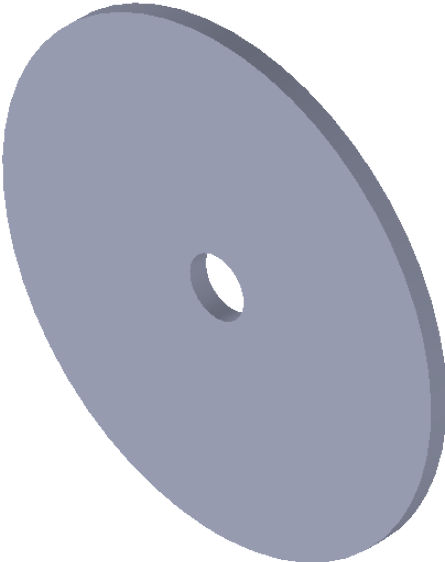
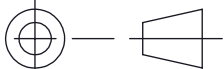
5	4	3	2	1
PERUBAHAN DARI :			DIGANTI DENGAN :	



5		4			3		2		1		
NO	PERUBAHAN	TANGGAL	NAMA	NO	PERUBAHAN	TANGGAL	NAMA				
				/							
											
1	Mal Lingkaran								A13		
JML	NAMA BAGIAN					POS	BAHAN	UKURAN JADI	UKURAN KASAR	NO. ID	F
>	0	6	30	120	400	1000	UKURAN LANJUT		NO. ORDER	PROYEKSI	
<	6	30	120	400	1000	2000					
TOL	±0.1	±0.2	±0.3	±0.5	±0.8	±1.2					
NAMA :								SKALA	DIGAMBAR	20-06-2022	FAJAR
<h1>Mal Lingkaran</h1>								1:1	DIPERIKSA		
									DISAHKAN		
NO. ASSY. :								FORMAT	SATUAN		
 POLITEKNIK NEGERI CILACAP, JURUSAN TEKNIK MESIN JL. dr. SOETOMO, NO. 01, SIDAKAYA, CILACAP, 53212 TELP : 0282 - 533329, E-mail :tmpnc@politeknikcilacap.ac.id								A4	mm	NO : 14/TM	
5		4			3		2		1		
PERUBAHAN DARI :						DIGANTI DENGAN :					

5	4	3	2	1			
NO	PERUBAHAN	TANGGAL	NAMA	NO	PERUBAHAN	TANGGAL	NAMA
				/			

1	Mal Lingkaran					A13	
JML	NAMA BAGIAN	POS	BAHAN	UKURAN JADI	UKURAN KASAR	NO. ID	F
>	0	6	30	120	400	1000	UKURAN LANJUT NO. ORDER PROYEKSI
<	6	30	120	400	1000	2000	
TOL	±0.1	±0.2	±0.3	±0.5	±0.8	±1.2	

NAMA : <h2 style="text-align: center;">Mal Lingkaran</h2>	SKALA <h1 style="text-align: center;">1:1</h1>	DIGAMBAR 20-06-2022	FAJAR	DIPERIKSA DISAHKAN
NO. ASSY. :	FORMAT <h2 style="text-align: center;">A4</h2>	SATUAN mm	NO : 14/TM	

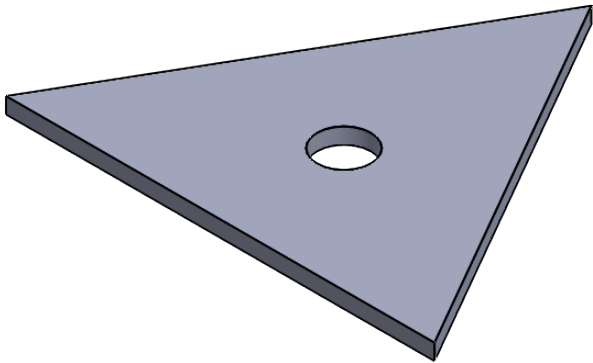
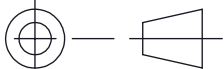
5	4	3	2	1
PERUBAHAN DARI :			DIGANTI DENGAN :	



5		4			3		2		1		
NO	PERUBAHAN	TANGGAL	NAMA	NO	PERUBAHAN	TANGGAL	NAMA				
				/							
E											E
D											D
C											C
B											B
1	Segitiga								A13		
JML	NAMA BAGIAN					POS	BAHAN	UKURAN JADI	UKURAN KASAR	NO. ID	F
>	0	6	30	120	400	1000	UKURAN LANJUT		NO. ORDER	PROYEKSI	
<	6	30	120	400	1000	2000					
TOL	±0.1	±0.2	±0.3	±0.5	±0.8	±1.2					
A	NAMA : <h2 style="text-align: center;">Mal Segitiga</h2>							SKALA	DIGAMBAR	20-06-2022	FAJAR
								1:1	DIPERIKSA		
									DISAHKAN		
	NO. ASSY. :										
	 POLITEKNIK NEGERI CILACAP, JURUSAN TEKNIK MESIN JL. dr. SOETOMO, NO. 01, SIDAKAYA, CILACAP, 53212 TELP : 0282 - 533329, E-mail :tmpnc@politeknikcilacap.ac.id							FORMAT	SATUAN		
								A4	mm	NO : 15/TM	
5		4			3		2		1		
PERUBAHAN DARI :					DIGANTI DENGAN :						

5	4	3	2	1			
NO	PERUBAHAN	TANGGAL	NAMA	NO	PERUBAHAN	TANGGAL	NAMA
				/			

1	Mal Segitiga					A13	
JML	NAMA BAGIAN	POS	BAHAN	UKURAN JADI	UKURAN KASAR	NO. ID	F
>	0	6	30	120	400	1000	UKURAN LANJUT NO. ORDER PROYEKSI
<	6	30	120	400	1000	2000	
TOL	±0.1	±0.2	±0.3	±0.5	±0.8	±1.2	
NAMA :				SKALA	DIGAMBAR	20-06-2022	FAJAR
<h1>Mal Segitiga</h1>				1:1	DIPERIKSA		
NO. ASSY. :					DISAHKAN		
POLITEKNIK NEGERI CILACAP, JURUSAN TEKNIK MESIN JL. dr. SOETOMO, NO. 01, SIDAKAYA, CILACAP, 53212 TELP : 0282 - 533329, E-mail :tmpnc@politeknikcilacap.ac.id				FORMAT	SATUAN	NO : 15/TM	
				A4	mm		

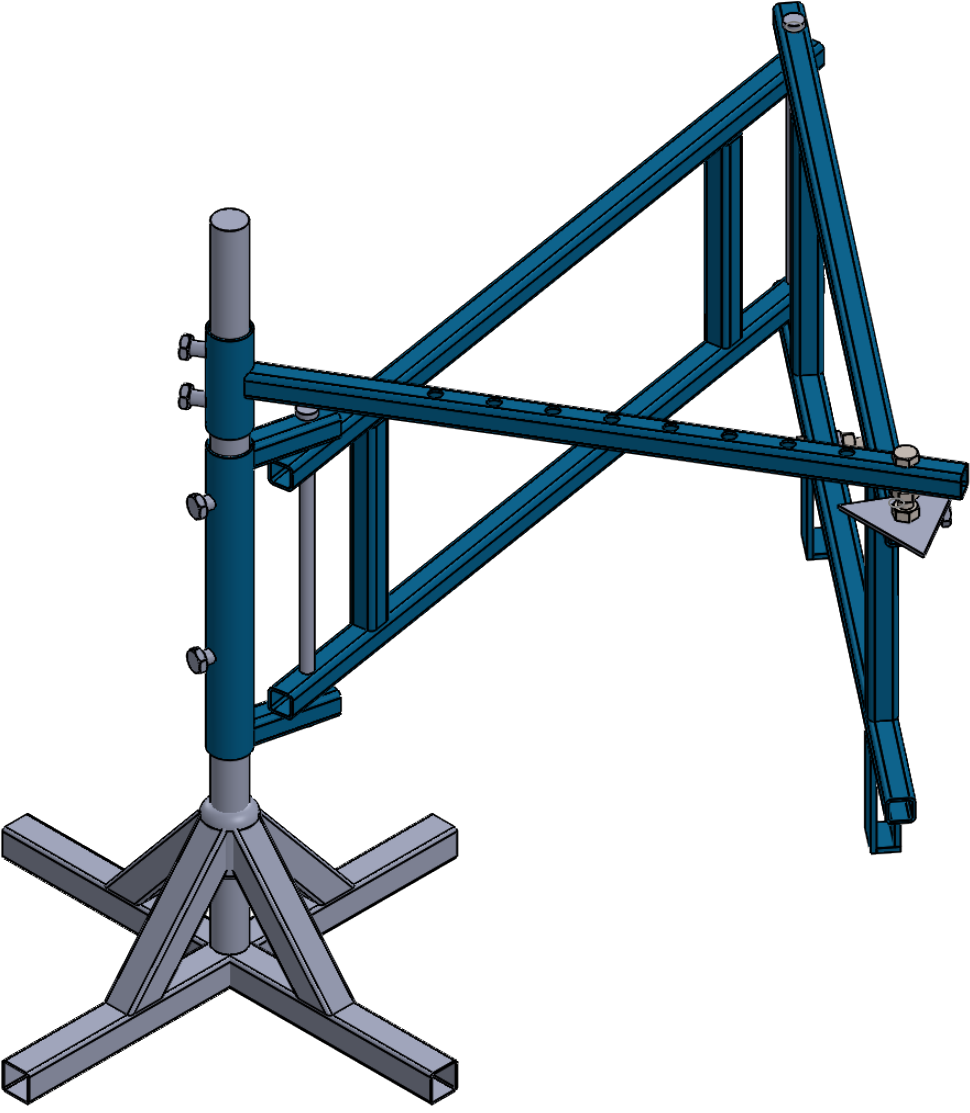
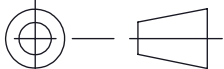

5	4	3	2	1
PERUBAHAN DARI :			DIGANTI DENGAN :	

LAMPIRAN 3
GAMBAR *ASSEMBLY*

	5		4		3		2		1				
NO	PERUBAHAN			TANGGAL	NAMA	NO	PERUBAHAN		TANGGAL	NAMA			
						/							
E											E		
D											D		
C											C		
B											B		
A											A		
	JML		NAMA BAGIAN			POS	BAHAN	UKURAN JADI		UKURAN KASAR		NO. ID	F
	>	0	6	30	120	400	1000	UKURAN LANJUT		NO. ORDER		PROYEKSI	
	<	6	30	120	400	1000	2000						
	TOL	±0.1	±0.2	±0.3	±0.5	±0.8	±1.2						
	NAMA :							SKALA	DIGAMBAR	20-01-2021	FAJAR		
	<h1 style="margin:0;">Assembly</h1>							<h1 style="margin:0;">1:5</h1>	DIPERIKSA				
	NO. ASSY. :							DISAHKAN					
	 POLITEKNIK NEGERI CILACAP, JURUSAN TEKNIK MESIN JL. dr. SOETOMO, NO. 01, SIDAKAYA, CILACAP, 53212 TELP : 0282 - 533329, E-mail :tmpnc@politeknikcilacap.ac.id							FORMAT	SATUAN		NO : 17/TM		
	5	4	3	2	1								
PERUBAHAN DARI :							DIGANTI DENGAN :						

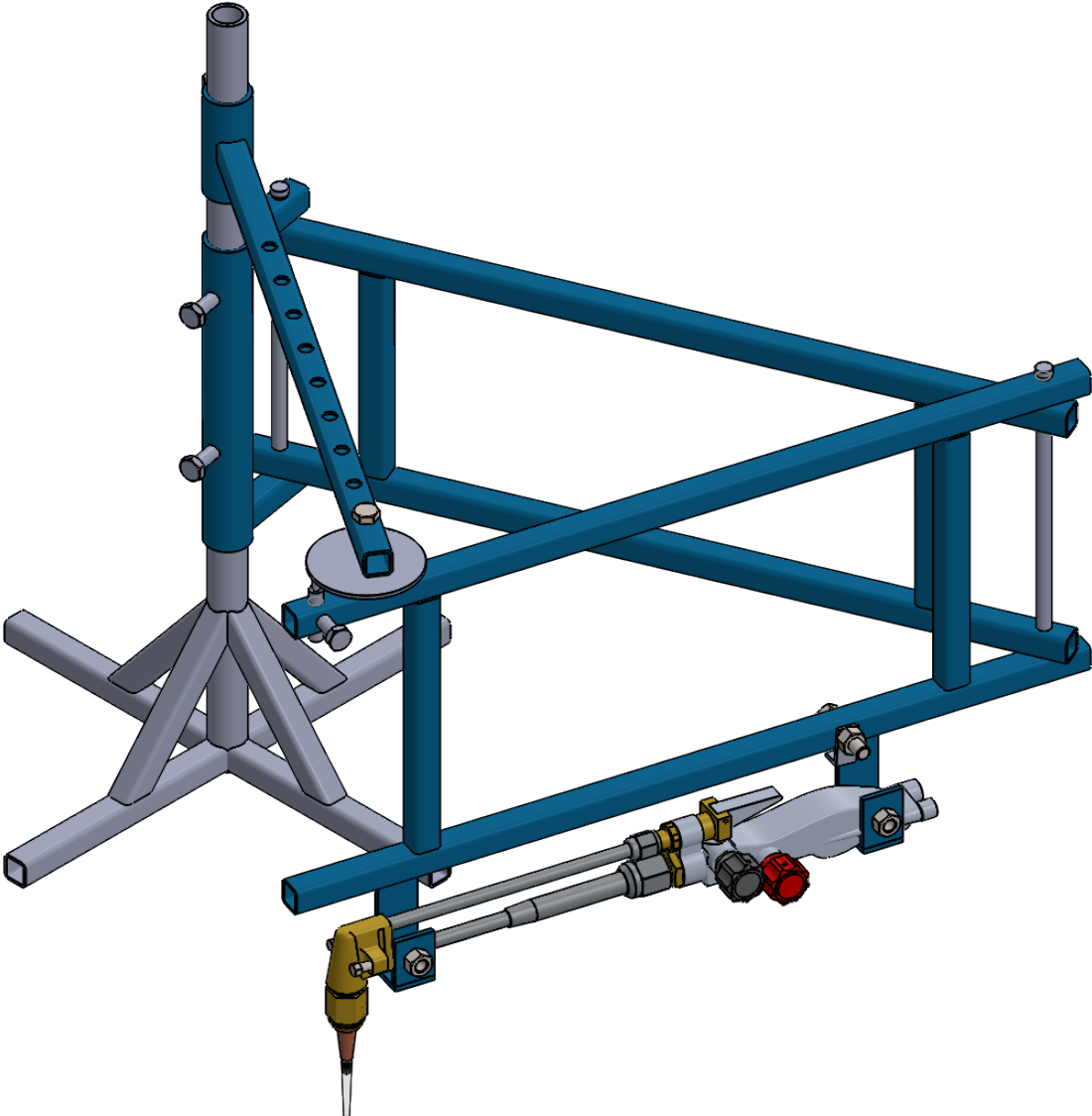
5		4			3		2		1	
NO	PERUBAHAN			TANGGAL	NAMA	NO	PERUBAHAN		TANGGAL	NAMA
						/				



JML	NAMA BAGIAN					POS	BAHAN	UKURAN JADI	UKURAN KASAR	NO. ID	F
>	0	6	30	120	400	1000	UKURAN LANJUT	NO. ORDER	PROYEKSI		
<	6	30	120	400	1000	2000			 		
TOL	±0.1	±0.2	±0.3	±0.5	±0.8	±1.2					

NAMA :

PENGAPLIKASIAN ALAT

NO. ASSY. :

SKALA	DIGAMBAR	20-06-2022	FAJAR
1:5	DIPERIKSA		
	DISAHKAN		



POLITEKNIK NEGERI CILACAP, JURUSAN TEKNIK MESIN
 JL. dr. SOETOMO, NO. 01, SIDAKAYA, CILACAP, 53212
 TELP : 0282 - 533329, E-mail :tmpnc@politeknikcilacap.ac.id

FORMAT	SATUAN	NO : 18/TM
A4	mm	

5		4			3		2		1	
PERUBAHAN DARI :		DIGANTI DENGAN :								

5		4		3		2		1	
NO	PERUBAHAN	TANGGAL	NAMA	NO	PERUBAHAN	TANGGAL	NAMA		
				∇					

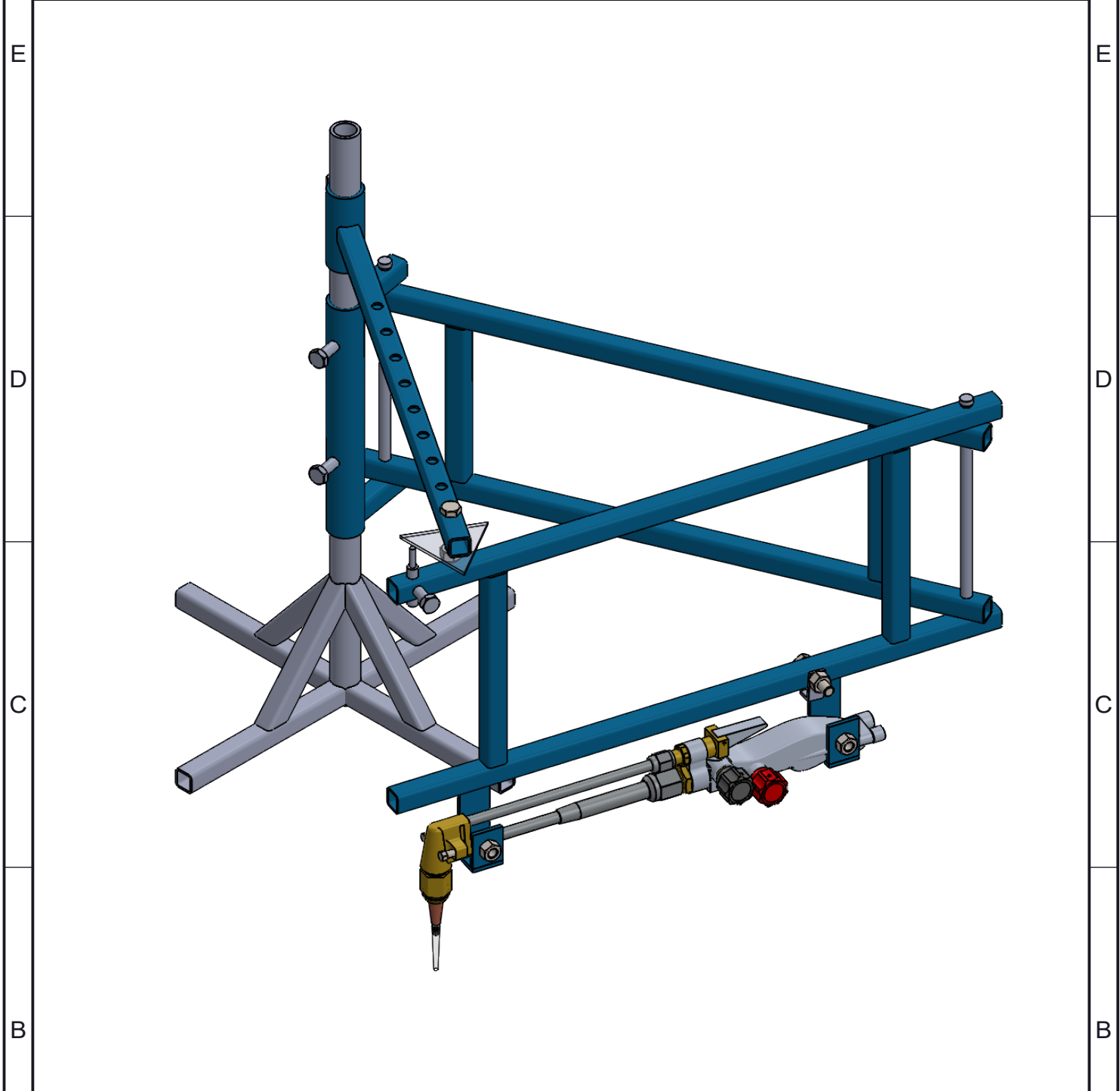

JML	NAMA BAGIAN					POS	BAHAN	UKURAN JADI	UKURAN KASAR	NO. ID	F
>	0	6	30	120	400	1000	UKURAN LANJUT	NO. ORDER	PROYEKSI		
<	6	30	120	400	1000	2000					
TOL	±0.1	±0.2	±0.3	±0.5	±0.8	±1.2					
NAMA :								SKALA	DIGAMBAR	20-06-2022	FAJAR
ASSEMBLY								1:5	DIPERIKSA		
									DISAHKAN		
NO. ASSY. :									FORMAT	SATUAN	NO :19/TM
POLITEKNIK NEGERI CILACAP, JURUSAN TEKNIK MESIN JL. dr. SOETOMO, NO. 01, SIDAKAYA, CILACAP, 53212 TELP : 0282 - 533329, E-mail :tmpnc@politeknikcilacap.ac.id								A4	mm		