

5		4		3		2		1	
NO	PERUBAHAN	TANGGAL	NAMA	NO	PERUBAHAN	TANGGAL	NAMA		
				△					

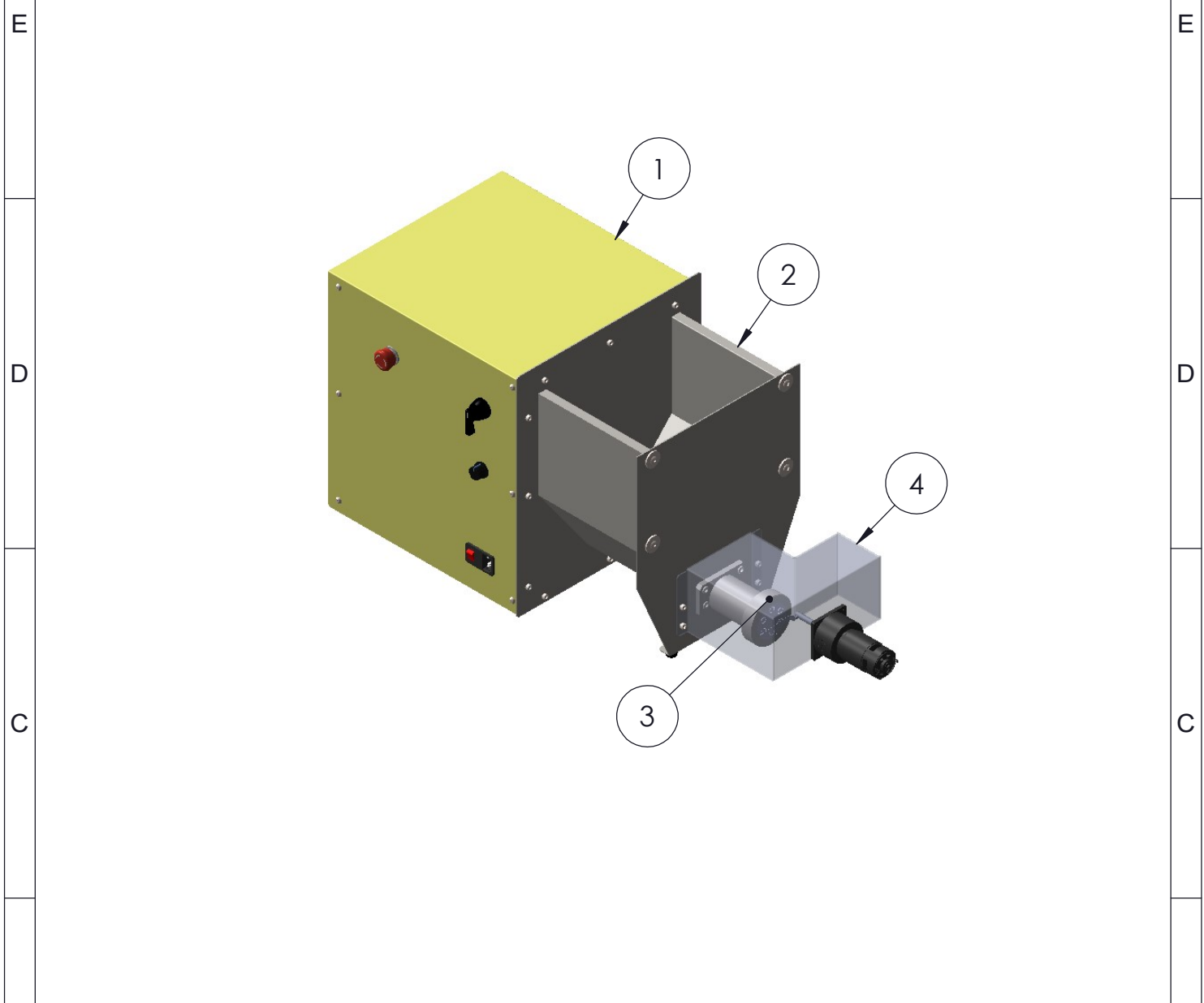

1	CUTTING ASSY	4	-			JTM19-04-00	
1	DIE ASSY	3	-			JTM19-03-00	
1	EXTRUDER ASSY	2	-			JTM19-02-00	
1	DRIVER ASSY	1	-			JTM19-01-00	

JML	NAMA BAGIAN					POS	BAHAN	UKURAN JADI	UKURAN KASAR	NO. ID	F
>	0	6	30	120	400	1000	UKURAN LANJUT	NO. ORDER	PROYEKSI		
<	6	30	120	400	1000	2000					
TOL	±0.1	±0.2	±0.3	±0.5	±0.8	±1.2					

NAMA :				SKALA	DIGAMBAR	06-06-2022	IQBAL
MACARONI MACHINE				1:8	DIPERIKSA		
					DISAHKAN		

NO. ASSY. :				FORMAT	JTM19-00-00		
POLITEKNIK NEGERI CILACAP, JURUSAN TEKNIK MESIN JL. dr. SOETOMO, NO. 01, SIDAKAYA, CILACAP, 53212 TELP : 0282 - 533329, E-mail : tmpnc@politeknikcilacap.ac.id				A4			

5	4	3	2	1
---	---	---	---	---

PERUBAHAN DARI :

DIGANTI DENGAN :

5		4		3		2		1	
NO	PERUBAHAN	TANGGAL	NAMA	NO	PERUBAHAN	TANGGAL	NAMA		
				△					

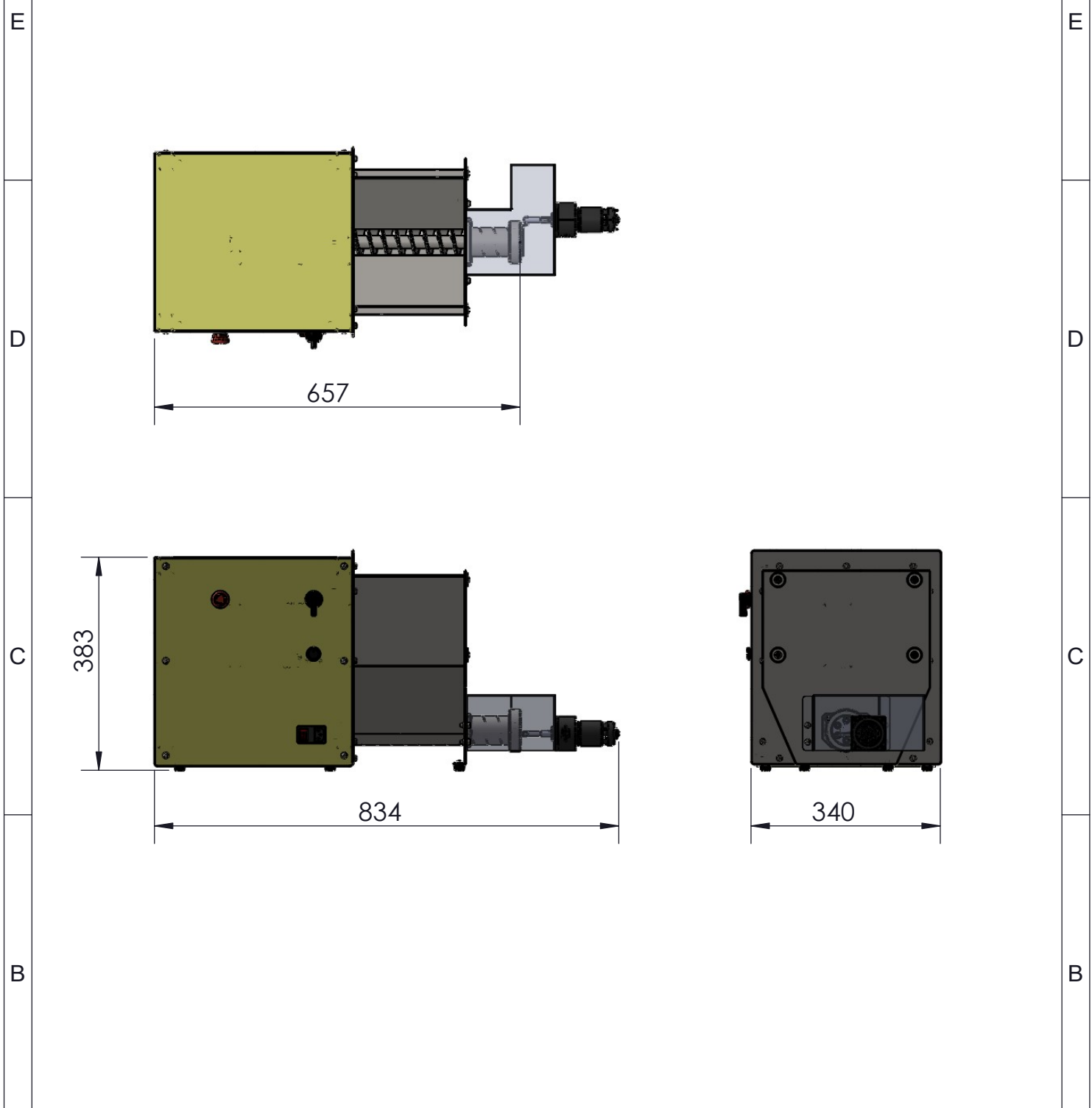

>	0	6	30	120	400	1000	UKURAN LANJUT	NO. ORDER	PROYEKSI		
<	6	30	120	400	1000	2000					
TOL	±0.1	±0.2	±0.3	±0.5	±0.8	±1.2					
NAMA :								SKALA	DIGAMBAR	06-06-2022	IQBAL
MACARONI MACHINE								1:10	DIPERIKSA		
									DISAHKAN		
NO. ASSY. :									FORMAT	JTM19-00-00	
POLITEKNIK NEGERI CILACAP, JURUSAN TEKNIK MESIN JL. dr. SOETOMO, NO. 01, SIDAKAYA, CILACAP, 53212 TELP : 0282 - 533329, E-mail : tmpnc@politeknikcilacap.ac.id								A4			

5		4		3		2		1	
NO	PERUBAHAN	TANGGAL	NAMA	NO	PERUBAHAN	TANGGAL	NAMA		
				△					

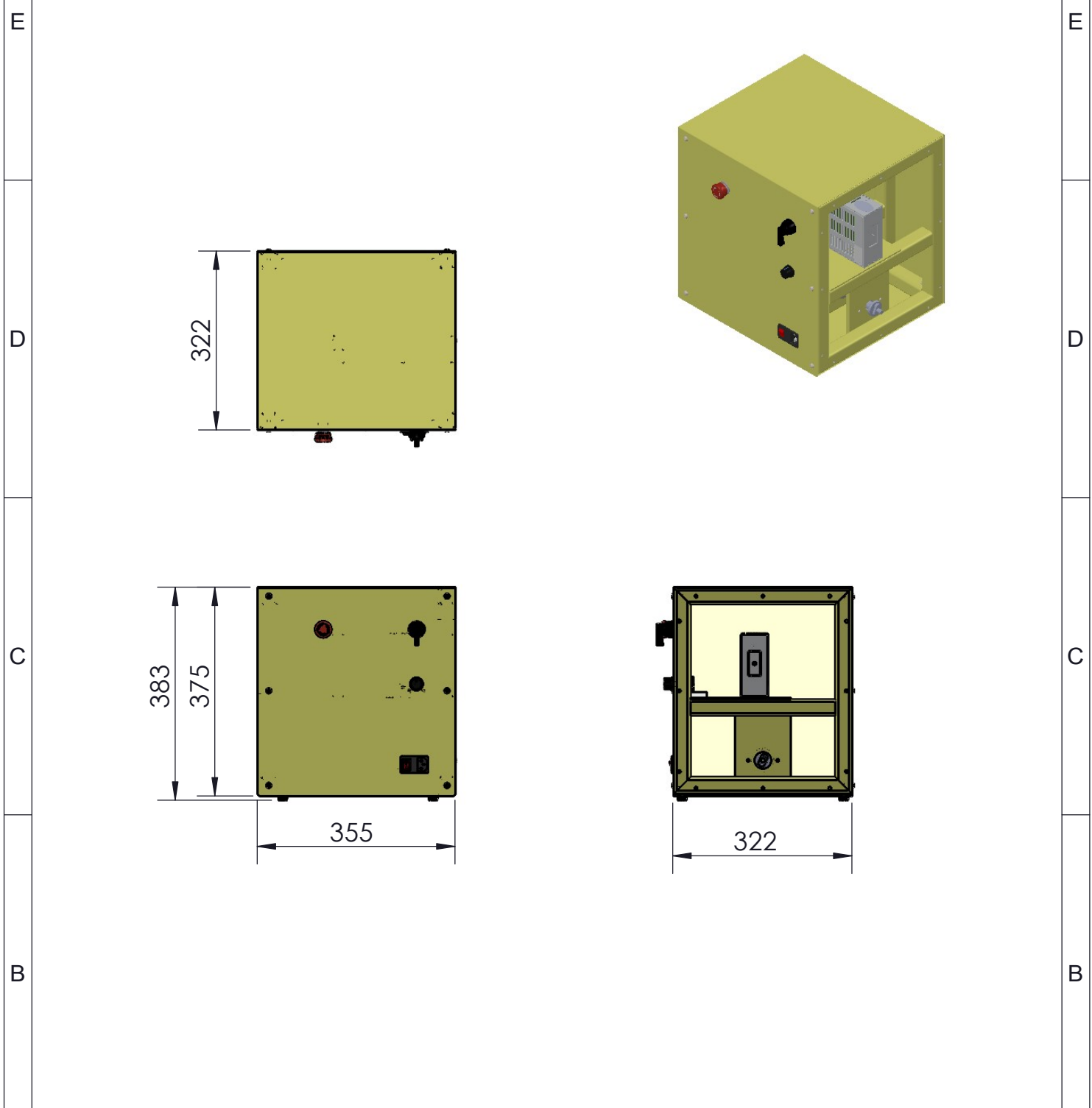

>	0	6	30	120	400	1000	UKURAN LANJUT
<	6	30	120	400	1000	2000	
TOL	±0.1	±0.2	±0.3	±0.5	±0.8	±1.2	

NO. ORDER		PROYEKSI	

NAMA :
DRIVER ASSY

NO. ASSY. :

SKALA 1:10	DIGAMBAR	06-06-2022	IQBAL
	DIPERIKSA		
	DISAHKAN		

POLITEKNIK NEGERI CILACAP, JURUSAN TEKNIK MESIN
 JL. dr. SOETOMO, NO. 01, SIDAKAYA, CILACAP, 53212
 TELP : 0282 - 533329, E-mail : tmpnc@politeknikcilacap.ac.id

FORMAT
A4

JTM19-01-00 (c)

5		4		3		2		1	
---	--	---	--	---	--	---	--	---	--

PERUBAHAN DARI :

DIGANTI DENGAN :

	5		4		3		2		1
NO	PERUBAHAN		TANGGAL	NAMA	NO	PERUBAHAN		TANGGAL	NAMA
					△				

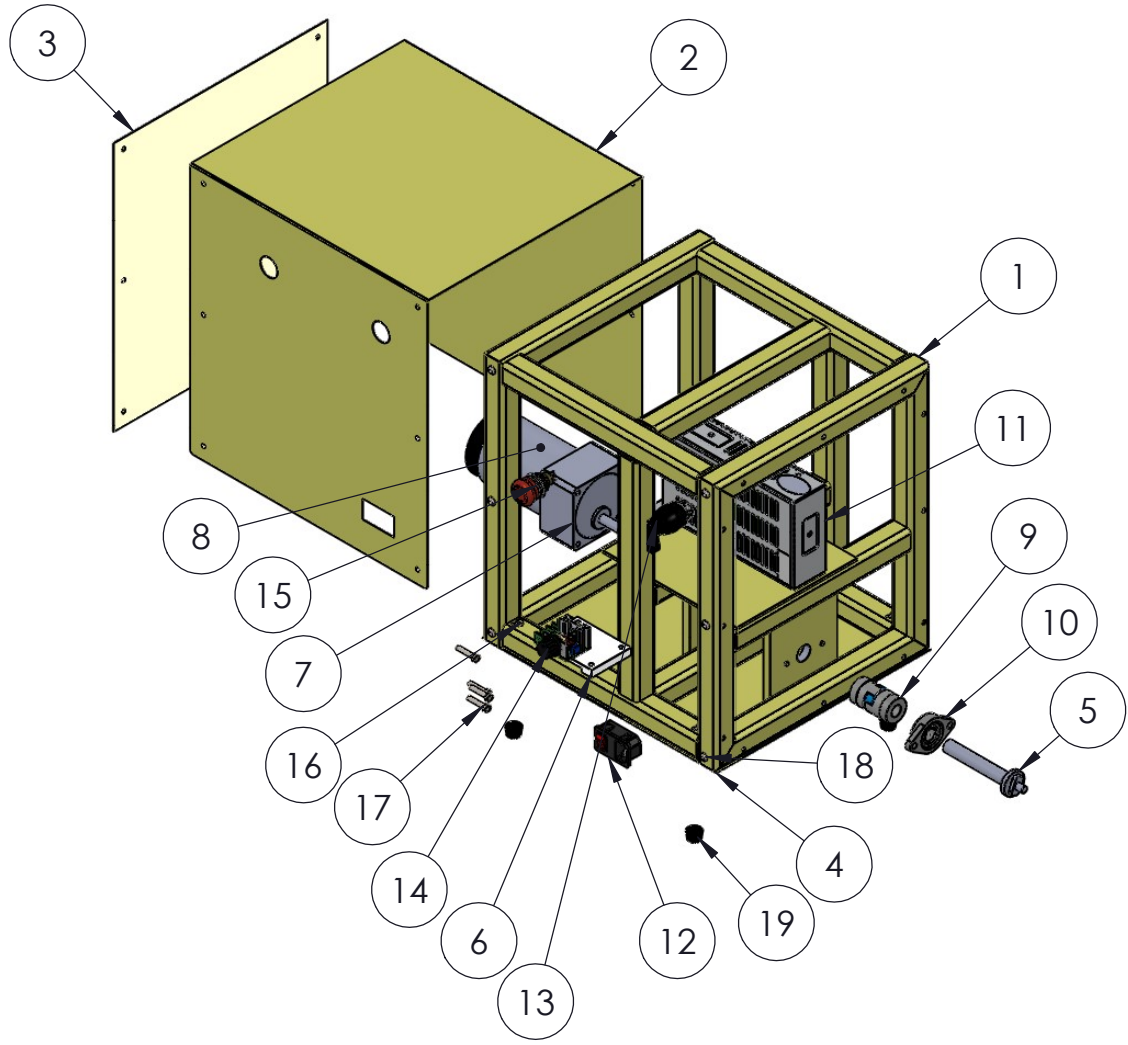

>	0	6	30	120	400	1000	UKURAN LANJUT
<	6	30	120	400	1000	2000	
TOL	±0.1	±0.2	±0.3	±0.5	±0.8	±1.2	

NO. ORDER		PROYEKSI	

NAMA :
DRIVER ASSY

NO. ASSY. :

SKALA 1:8	DIGAMBAR	06-06-2022	IQBAL
	DIPERIKSA		
	DISAHKAN		

POLITEKNIK NEGERI CILACAP, JURUSAN TEKNIK MESIN
 JL. dr. SOETOMO, NO. 01, SIDAKAYA, CILACAP, 53212
 TELP : 0282 - 533329, E-mail : tmpnc@politeknikcilacap.ac.id

FORMAT A4	JTM19-01-00 (a)
---------------------	------------------------

5		4			3		2		1	
NO	PERUBAHAN			TANGGAL	NAMA	NO	PERUBAHAN		TANGGAL	NAMA
E										
D										
4	RUBBER FOOT			19	STD	-	-		-	
22	L HEX SBHCS			18	STD	M5x0.8x10	-		-	
4	HEX HEAD SCREW			17	STD	M5x0.8x25	-		-	
4	L HEX SHCS			16	STD	M4x0.7x35	-		-	
1	EMERGENCY BUTTON			15	STD	-	-		-	
1	DIMMER			14	STD	DC12V-40V 10A	-		-	
1	SELECTOR SWITCH			13	STD	-	-		-	
1	SOCKET FUSE			12	STD	-	-		-	
1	POWER SUPPLY UNIT			11	STD	220V TO 24V12V10A	-		-	
1	PILLOW BLOCK BEARING			10	STD	KFL002	-		-	
1	JAW COUPLING			9	STD	-	-		-	
1	MOTOR DC			8	STD	4DC-25W-GN-YG	-		-	
1	GEARBOX			7	STD	4GN50K	-		-	
1	BASE DIMMER			6	ACRYLIC	LIHAT DETAIL	-		JTM19-01-06	
1	SHAFT DRIVEN			5	S45C	LIHAT DETAIL	-		JTM19-01-05	
1	BOTTOM COVER			4	SPCC	LIHAT DETAIL	-		JTM19-01-04	
1	BACK COVER			3	SPCC	LIHAT DETAIL	-		JTM19-01-03	
1	TOP-SIDE COVER			2	SPCC	LIHAT DETAIL	-		JTM19-01-02	
1	FRAME			1	MILD STEEL	LIHAT DETAIL	-		JTM19-01-01	
JML	NAMA BAGIAN			POS	BAHAN	UKURAN JADI	UKURAN KASAR		NO. ID	F
>	0	6	30	120	400	1000	UKURAN LANJUT		NO. ORDER	PROYEKSI 
<	6	30	120	400	1000	2000				
TOL	±0.1	±0.2	±0.3	±0.5	±0.8	±1.2				
NAMA :							SKALA	DIGAMBAR	06-06-2022	IQBAL
DRIVER ASSY							1:8	DIPERIKSA		
								DISAHKAN		
NO. ASSY. :							FORMAT	JTM19-01-00 (b)		
 POLITEKNIK NEGERI CILACAP, JURUSAN TEKNIK MESIN JL. dr. SOETOMO, NO. 01, SIDAKAYA, CILACAP, 53212 TELP : 0282 - 533329, E-mail : tmpnc@politeknikcilacap.ac.id							A4			
5		4			3		2		1	

PERUBAHAN DARI :

DIGANTI DENGAN :

5		4		3		2		1	
NO	PERUBAHAN	TANGGAL	NAMA	NO	PERUBAHAN	TANGGAL	NAMA		
				△					

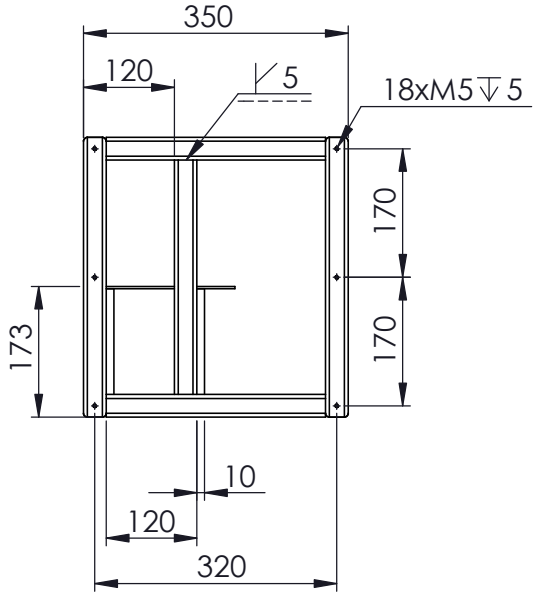
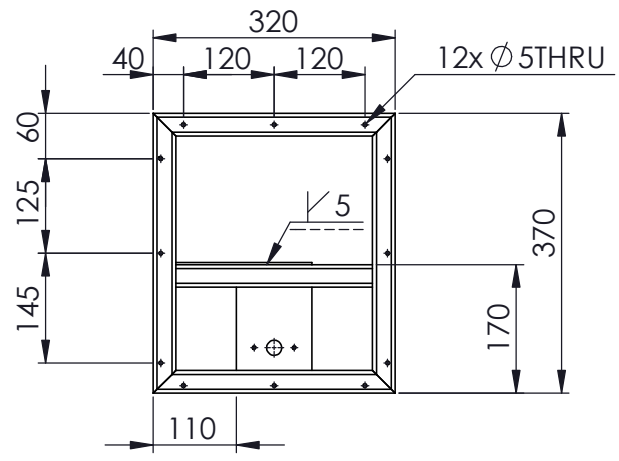
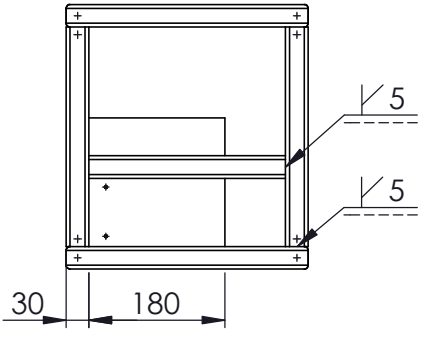
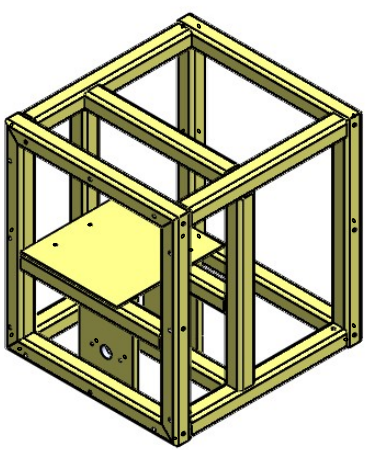

>	0	6	30	120	400	1000	UKURAN LANJUT
<	6	30	120	400	1000	2000	
TOL	±0.1	±0.2	±0.3	±0.5	±0.8	±1.2	

NO. ORDER		PROYEKSI	

NAMA :
FRAME
NO. ASSY. :

SKALA 1:10	DIGAMBAR	06-06-2022	IQBAL
	DIPERIKSA		
	DISAHKAN		

POLITEKNIK NEGERI CILACAP, JURUSAN TEKNIK MESIN
 JL. dr. SOETOMO, NO. 01, SIDAKAYA, CILACAP, 53212
 TELP : 0282 - 533329, E-mail : tmpnc@politeknikcilacap.ac.id

FORMAT A4	JTM19-01-01 (b)
---------------------	------------------------

5		4		3		2		1	
NO	PERUBAHAN	TANGGAL	NAMA	NO	PERUBAHAN	TANGGAL	NAMA		
				△					

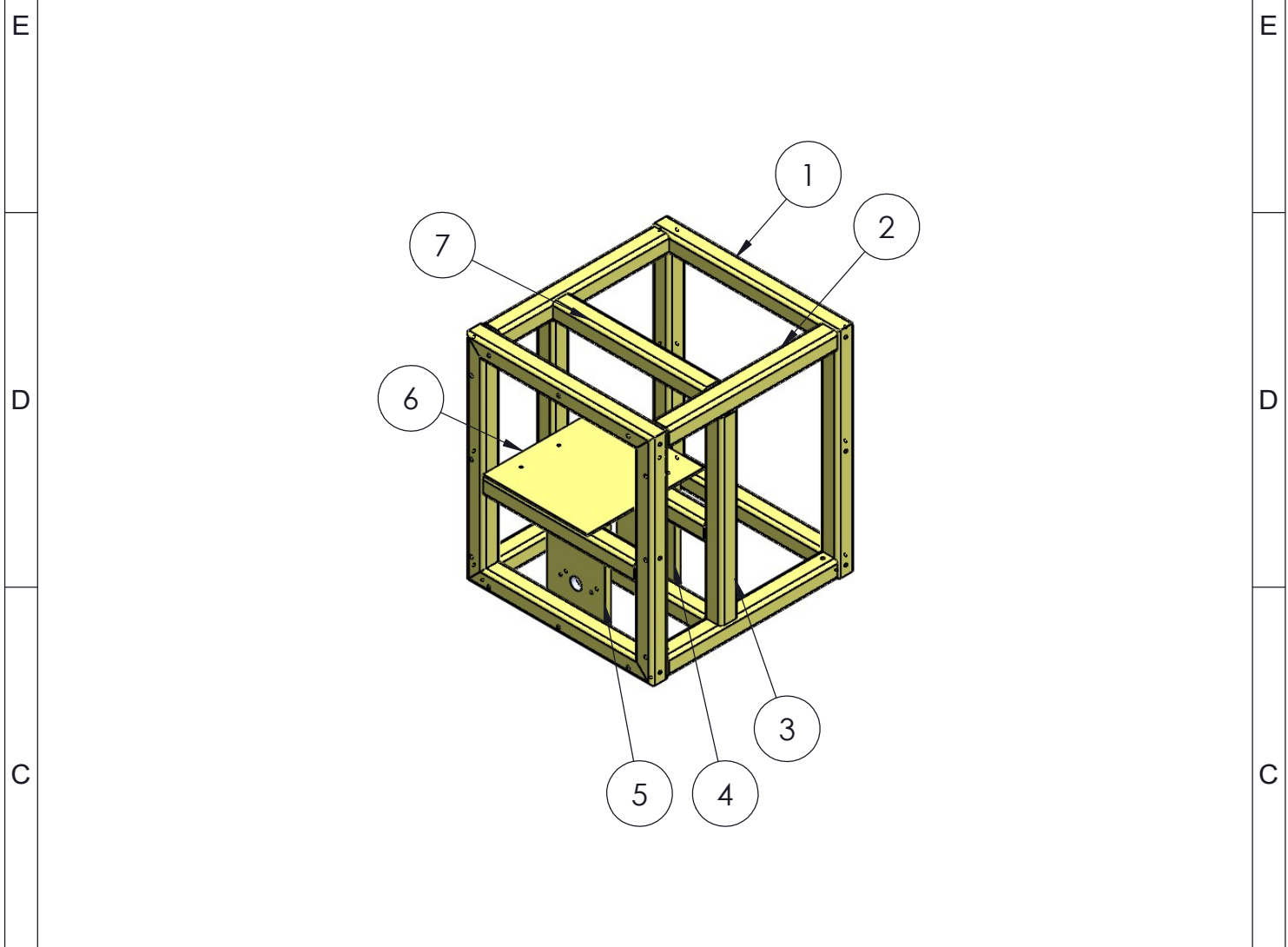

4	FRAME 03	7	HOLLOW	LIHAT DETAIL	-	JTM19-01-01-07
1	PSU BASE	6	MILD STEEL	LIHAT DETAIL	-	JTM19-01-01-06
1	BRACKET BEARING	5	MILD STEEL	LIHAT DETAIL	-	JTM19-01-01-05
1	BRACKET MOTOR	4	MILD STEEL	LIHAT DETAIL	-	JTM19-01-01-04
2	SUPPORT	3	HOLLOW	LIHAT DETAIL	-	JTM19-01-01-03
4	FRAME 02	2	HOLLOW	LIHAT DETAIL	-	JTM19-01-01-02
2	FRAME 01	1	HOLLOW	LIHAT DETAIL	-	JTM19-01-01-01

JML	NAMA BAGIAN					POS	BAHAN	UKURAN JADI	UKURAN KASAR	NO. ID	F
>	0	6	30	120	400	1000	UKURAN LANJUT		NO. ORDER	PROYEKSI	
<	6	30	120	400	1000	2000					
TOL	±0.1	±0.2	±0.3	±0.5	±0.8	±1.2					

NAMA :				SKALA	DIGAMBAR	06-06-2022	IQBAL
FRAME				1:8	DIPERIKSA		
					DISAHKAN		

NO. ASSY. :				FORMAT	JTM19-01-01 (a)		
POLITEKNIK NEGERI CILACAP, JURUSAN TEKNIK MESIN JL. dr. SOETOMO, NO. 01, SIDAKAYA, CILACAP, 53212 TELP : 0282 - 533329, E-mail : tmpnc@politeknikcilacap.ac.id				A4			

5	4	3	2	1
---	---	---	---	---

PERUBAHAN DARI :

DIGANTI DENGAN :

5		4		3		2		1	
NO	PERUBAHAN	TANGGAL	NAMA	NO	PERUBAHAN	TANGGAL	NAMA		
				△					

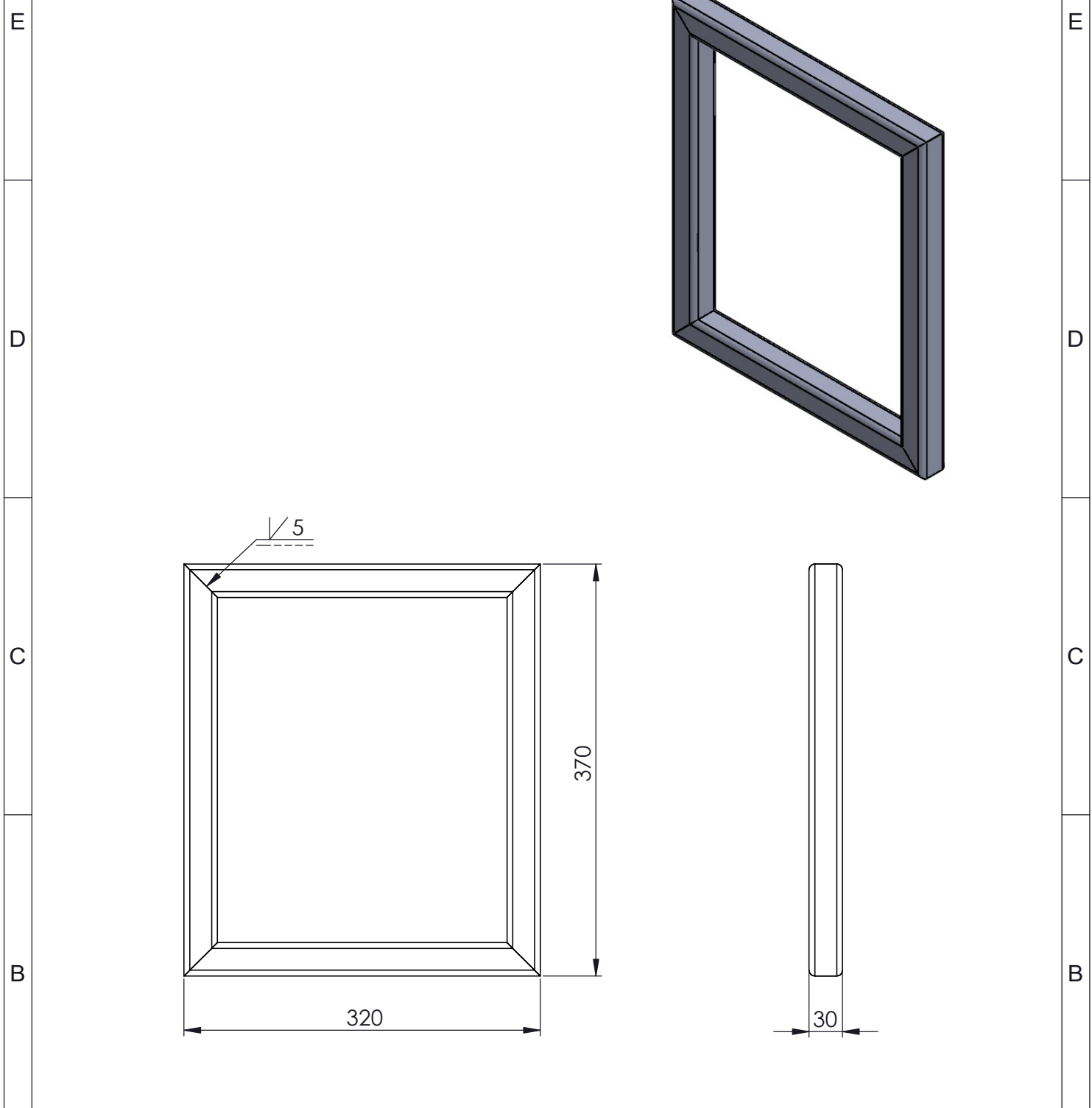

>	0	6	30	120	400	1000	UKURAN LANJUT	NO. ORDER	PROYEKSI				
<	6	30	120	400	1000	2000				SKALA	DIGAMBAR	06-06-2022	IQBAL
TOL	±0.1	±0.2	±0.3	±0.5	±0.8	±1.2					1:5	DIPERIKSA	
NAMA :								FORMAT	JTM19-01-01-01				
FRAME 01									A4				
NO. ASSY. :								POLITEKNIK NEGERI CILACAP, JURUSAN TEKNIK MESIN					
								JL. dr. SOETOMO, NO. 01, SIDAKAYA, CILACAP, 53212 TELP : 0282 - 533329, E-mail : tmpnc@politeknikcilacap.ac.id					
5		4		3		2		1					

PERUBAHAN DARI :

DIGANTI DENGAN :

5		4		3		2		1	
NO	PERUBAHAN	TANGGAL	NAMA	NO	PERUBAHAN	TANGGAL	NAMA		
				△					

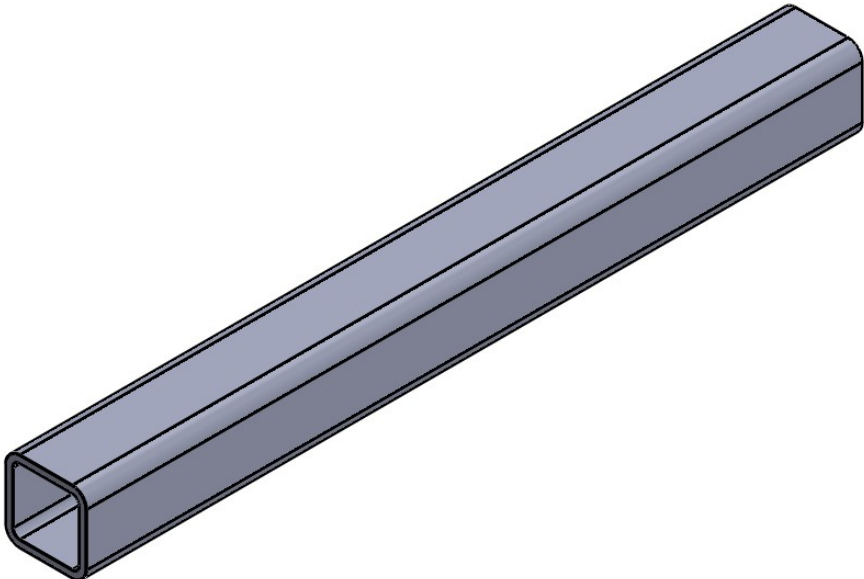

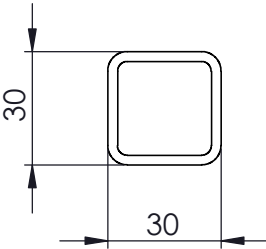

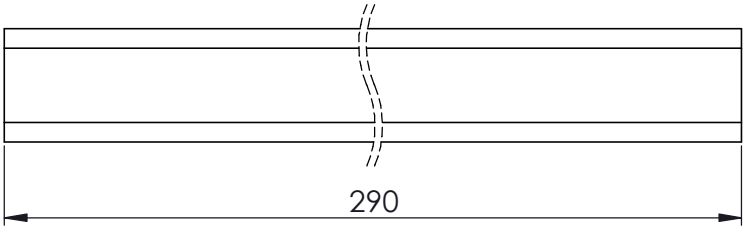

30
30

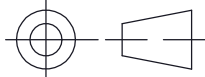

290

>	0	6	30	120	400	1000	UKURAN LANJUT	NO. ORDER	PROYEKSI			
<	6	30	120	400	1000	2000						
TOL	±0.1	±0.2	±0.3	±0.5	±0.8	±1.2						

NAMA : <div style="text-align: center; font-size: 1.2em; font-weight: bold;">FRAME 02</div>	SKALA <div style="text-align: center; font-size: 1.5em; font-weight: bold;">1:2</div>	DIGAMBAR 06-06-2022 DIPERIKSA DISAHKAN	IQBAL
--	--	---	-------

NO. ASSY. :  POLITEKNIK NEGERI CILACAP, JURUSAN TEKNIK MESIN JL. dr. SOETOMO, NO. 01, SIDAKAYA, CILACAP, 53212 TELP : 0282 - 533329, E-mail : tmpnc@politeknikcilacap.ac.id	FORMAT <div style="text-align: center; font-size: 1.5em; font-weight: bold;">A4</div>	JTM19-01-01-02
---	--	----------------

PERUBAHAN DARI :
DIGANTI DENGAN :

5		4		3		2		1	
NO	PERUBAHAN	TANGGAL	NAMA	NO	PERUBAHAN	TANGGAL	NAMA		
				△					

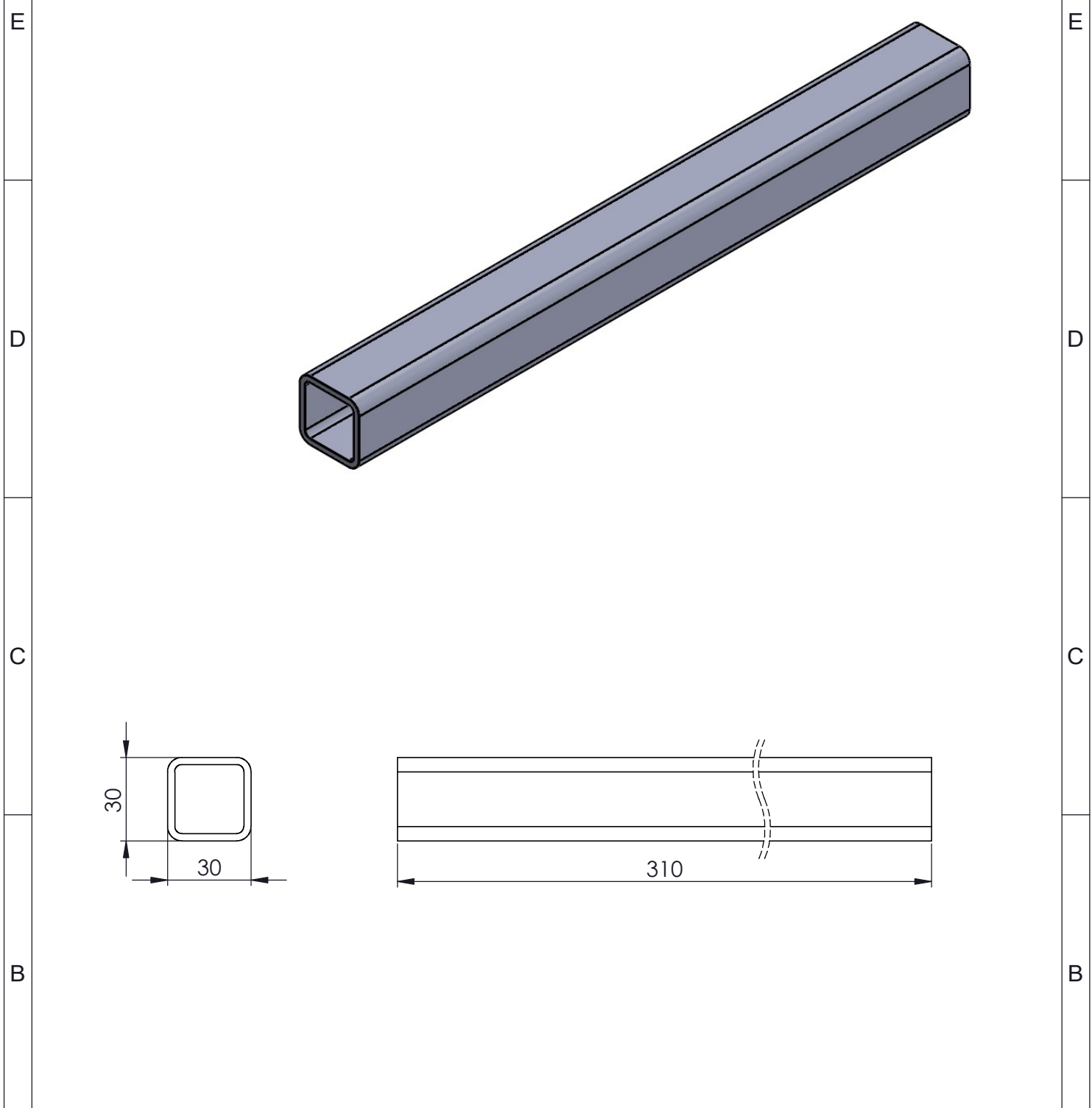

>	0	6	30	120	400	1000	UKURAN LANJUT	NO. ORDER	PROYEKSI		
<	6	30	120	400	1000	2000					
TOL	±0.1	±0.2	±0.3	±0.5	±0.8	±1.2					
NAMA :								SKALA	DIGAMBAR	06-06-2022	IQBAL
SUPPORT								1:2	DIPERIKSA		
									DISAHKAN		
NO. ASSY. :									FORMAT	JTM19-01-01-03	
POLITEKNIK NEGERI CILACAP, JURUSAN TEKNIK MESIN JL. dr. SOETOMO, NO. 01, SIDAKAYA, CILACAP, 53212 TELP : 0282 - 533329, E-mail : tmpnc@politeknikcilacap.ac.id								A4			

5		4		3		2		1	
NO	PERUBAHAN	TANGGAL	NAMA	NO	PERUBAHAN	TANGGAL	NAMA		
				△					

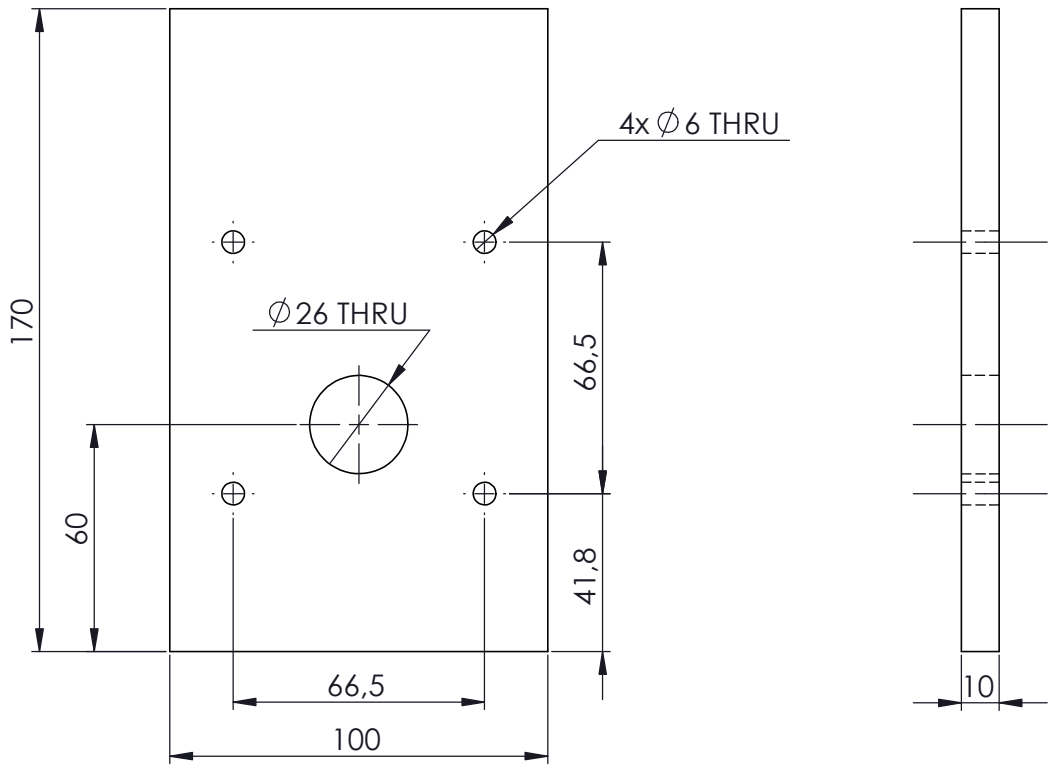
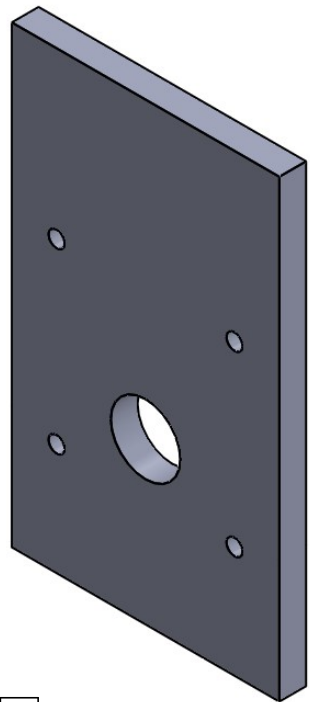

>	0	6	30	120	400	1000	UKURAN LANJUT
<	6	30	120	400	1000	2000	
TOL	±0.1	±0.2	±0.3	±0.5	±0.8	±1.2	

NO. ORDER		PROYEKSI	

NAMA :
BRACKET MOTOR

NO. ASSY. :

SKALA 1:2	DIGAMBAR	06-06-2022	IQBAL
	DIPERIKSA		
	DISAHKAN		

POLITEKNIK NEGERI CILACAP, JURUSAN TEKNIK MESIN
 JL. dr. SOETOMO, NO. 01, SIDAKAYA, CILACAP, 53212
 TELP : 0282 - 533329, E-mail : tmpnc@politeknikcilacap.ac.id

FORMAT
A4

JTM19-01-01-04

5		4		3		2		1	
---	--	---	--	---	--	---	--	---	--

PERUBAHAN DARI :

DIGANTI DENGAN :

5		4		3		2		1	
NO	PERUBAHAN	TANGGAL	NAMA	NO	PERUBAHAN	TANGGAL	NAMA		
				△					

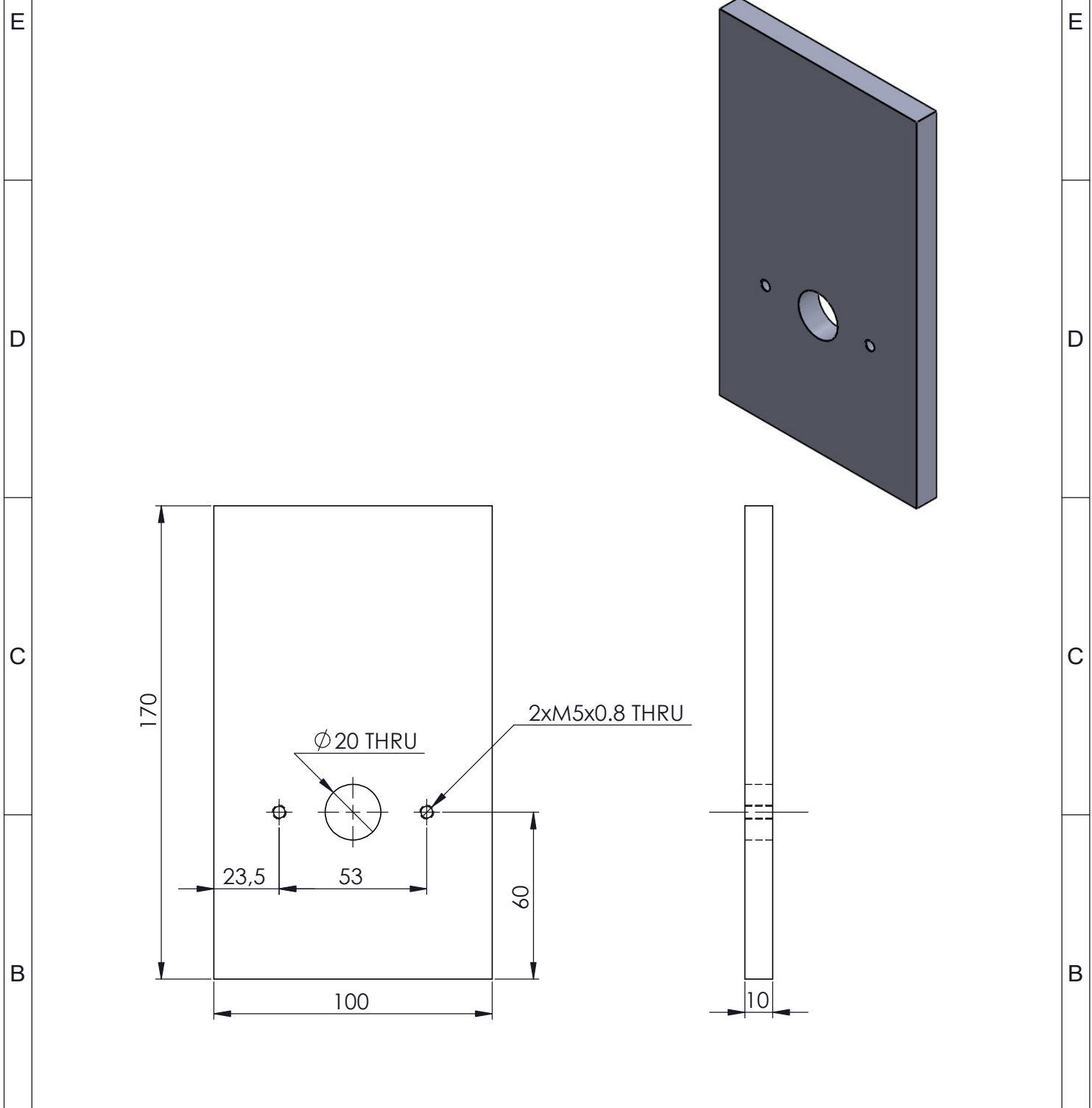

>	0	6	30	120	400	1000	UKURAN LANJUT
<	6	30	120	400	1000	2000	
TOL	±0.1	±0.2	±0.3	±0.5	±0.8	±1.2	

NO. ORDER		PROYEKSI	

NAMA :
BRACKET BEARING
 NO. ASSY. :

SKALA 1:2	DIGAMBAR	06-06-2022	IQBAL
	DIPERIKSA		
	DISAHKAN		





POLITEKNIK NEGERI CILACAP, JURUSAN TEKNIK MESIN
 JL. dr. SOETOMO, NO. 01, SIDAKAYA, CILACAP, 53212
 TELP : 0282 - 533329, E-mail : tmpnc@politeknikcilacap.ac.id

FORMAT A4	JTM19-01-01-05
---------------------	-----------------------

5		4		3		2		1	
---	--	---	--	---	--	---	--	---	--

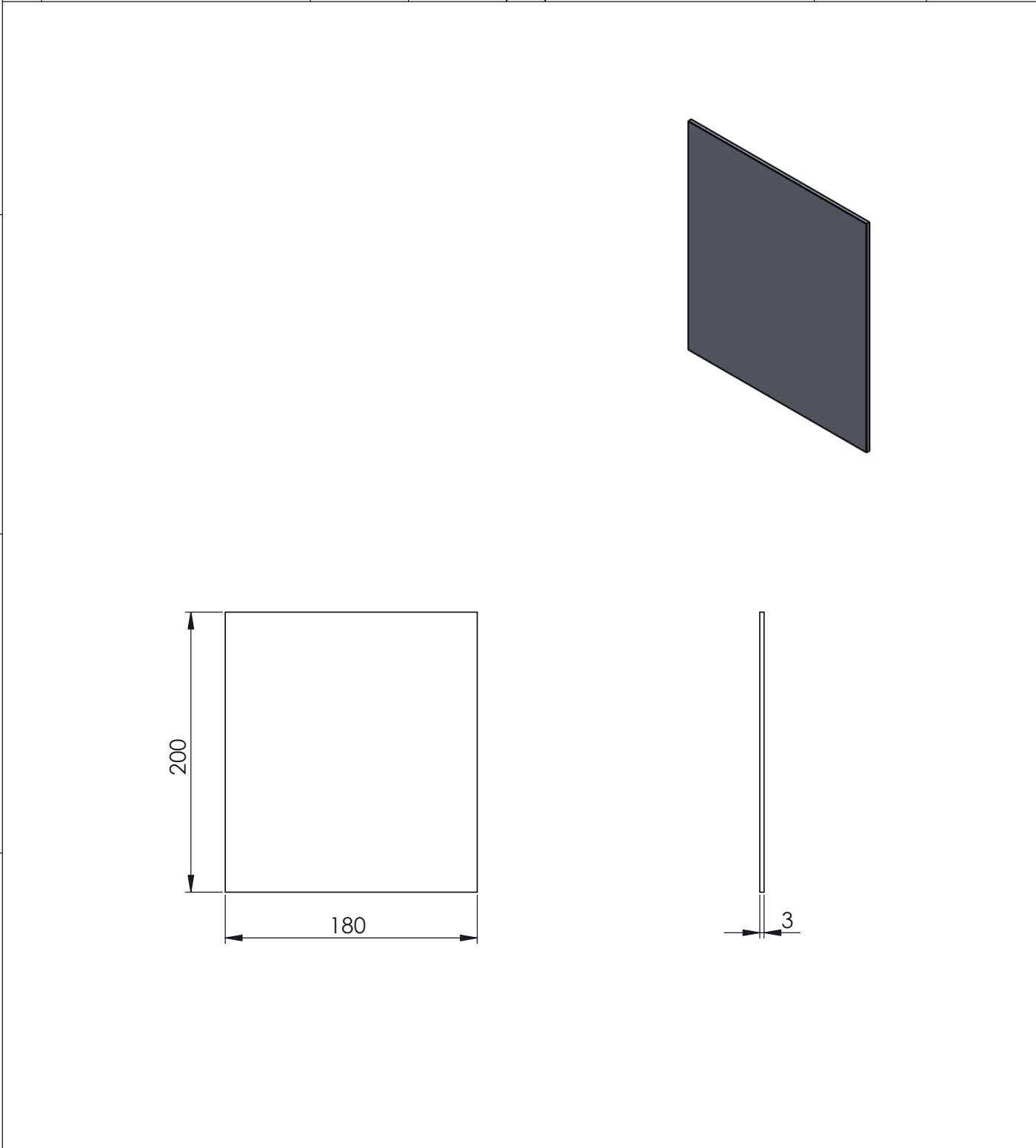
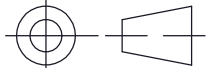
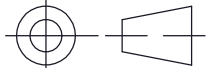
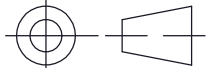
PERUBAHAN DARI :

DIGANTI DENGAN :

5		4			3		2		1																																					
NO	PERUBAHAN	TANGGAL	NAMA	NO	PERUBAHAN	TANGGAL	NAMA																																							
				△																																										
E											E																																			
D											D																																			
C											C																																			
B											B																																			
<table border="1" style="width:100%; border-collapse: collapse;"> <tr> <td>></td> <td>0</td> <td>6</td> <td>30</td> <td>120</td> <td>400</td> <td>1000</td> <td rowspan="3" style="text-align: center;">UKURAN LANJUT</td> <td rowspan="3" style="text-align: center;">NO. ORDER</td> <td colspan="2" style="text-align: center;">PROYEKSI</td> </tr> <tr> <td><</td> <td>6</td> <td>30</td> <td>120</td> <td>400</td> <td>1000</td> <td>2000</td> <td colspan="2" style="text-align: center;">  </td> </tr> <tr> <td>TOL</td> <td>±0.1</td> <td>±0.2</td> <td>±0.3</td> <td>±0.5</td> <td>±0.8</td> <td>±1.2</td> </tr> </table>							>	0	6	30	120	400	1000	UKURAN LANJUT	NO. ORDER	PROYEKSI		<	6	30	120	400	1000	2000			TOL	±0.1	±0.2	±0.3	±0.5	±0.8	±1.2	<table border="1" style="width:100%; border-collapse: collapse;"> <tr> <td rowspan="3" style="text-align: center; vertical-align: middle;">SKALA 1:4</td> <td>DIGAMBAR</td> <td>06-06-2022</td> <td>IQBAL</td> </tr> <tr> <td>DIPERIKSA</td> <td></td> <td></td> </tr> <tr> <td>DISAHKAN</td> <td></td> <td></td> </tr> </table>		SKALA 1:4	DIGAMBAR	06-06-2022	IQBAL	DIPERIKSA			DISAHKAN			A
>	0	6	30	120	400	1000	UKURAN LANJUT	NO. ORDER	PROYEKSI																																					
<	6	30	120	400	1000	2000																																								
TOL	±0.1	±0.2	±0.3	±0.5	±0.8	±1.2																																								
SKALA 1:4	DIGAMBAR	06-06-2022	IQBAL																																											
	DIPERIKSA																																													
	DISAHKAN																																													
<p>NAMA :</p> <p style="text-align: center; font-size: 1.2em;">PSU BASE</p> <p>NO. ASSY. :</p>							<table border="1" style="width:100%; border-collapse: collapse;"> <tr> <td rowspan="2" style="text-align: center; vertical-align: middle;">FORMAT A4</td> <td colspan="2" style="text-align: center; font-size: 1.2em;">JTM19-01-01-06</td> </tr> </table>		FORMAT A4	JTM19-01-01-06		A																																		
FORMAT A4	JTM19-01-01-06																																													
	<table border="1" style="width:100%; border-collapse: collapse;"> <tr> <td colspan="7" style="text-align: center;">  POLITEKNIK NEGERI CILACAP, JURUSAN TEKNIK MESIN JL. dr. SOETOMO, NO. 01, SIDAKAYA, CILACAP, 53212 TELP : 0282 - 533329, E-mail : tmpnc@politeknikcilacap.ac.id </td> <td colspan="2" style="text-align: center;"> DIGANTI DENGAN : </td> </tr> </table>							 POLITEKNIK NEGERI CILACAP, JURUSAN TEKNIK MESIN JL. dr. SOETOMO, NO. 01, SIDAKAYA, CILACAP, 53212 TELP : 0282 - 533329, E-mail : tmpnc@politeknikcilacap.ac.id							DIGANTI DENGAN :		A																													
 POLITEKNIK NEGERI CILACAP, JURUSAN TEKNIK MESIN JL. dr. SOETOMO, NO. 01, SIDAKAYA, CILACAP, 53212 TELP : 0282 - 533329, E-mail : tmpnc@politeknikcilacap.ac.id							DIGANTI DENGAN :																																							
5		4			3		2		1																																					

PERUBAHAN DARI :

DIGANTI DENGAN :

5		4		3		2		1	
NO	PERUBAHAN	TANGGAL	NAMA	NO	PERUBAHAN	TANGGAL	NAMA		
				△					

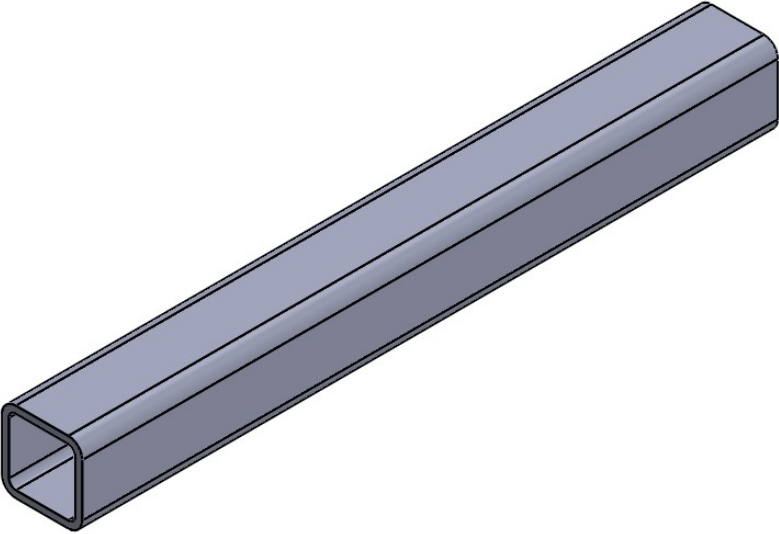

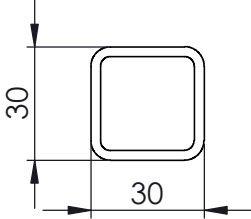

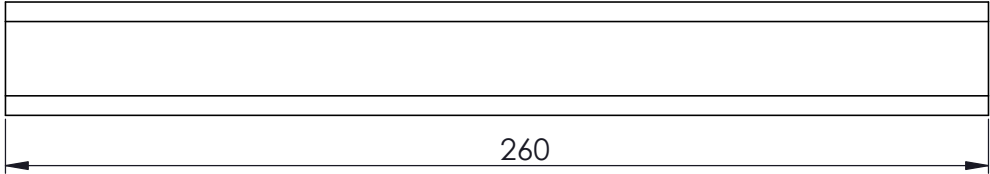

30
30



260

>	0	6	30	120	400	1000	UKURAN LANJUT	NO. ORDER	PROYEKSI		
<	6	30	120	400	1000	2000					
TOL	±0.1	±0.2	±0.3	±0.5	±0.8	±1.2					
NAMA :								SKALA	DIGAMBAR	06-06-2022	IQBAL
FRAME 03								1:2	DIPERIKSA		
NO. ASSY. :								DISAHKAN			
 POLITEKNIK NEGERI CILACAP, JURUSAN TEKNIK MESIN JL. dr. SOETOMO, NO. 01, SIDAKAYA, CILACAP, 53212 TELP : 0282 - 533329, E-mail : tmpnc@politeknikcilacap.ac.id								FORMAT	JTM19-01-01-07		
5		4		3		2		1			

5		4		3		2		1	
NO	PERUBAHAN	TANGGAL	NAMA	NO	PERUBAHAN	TANGGAL	NAMA		
				△					

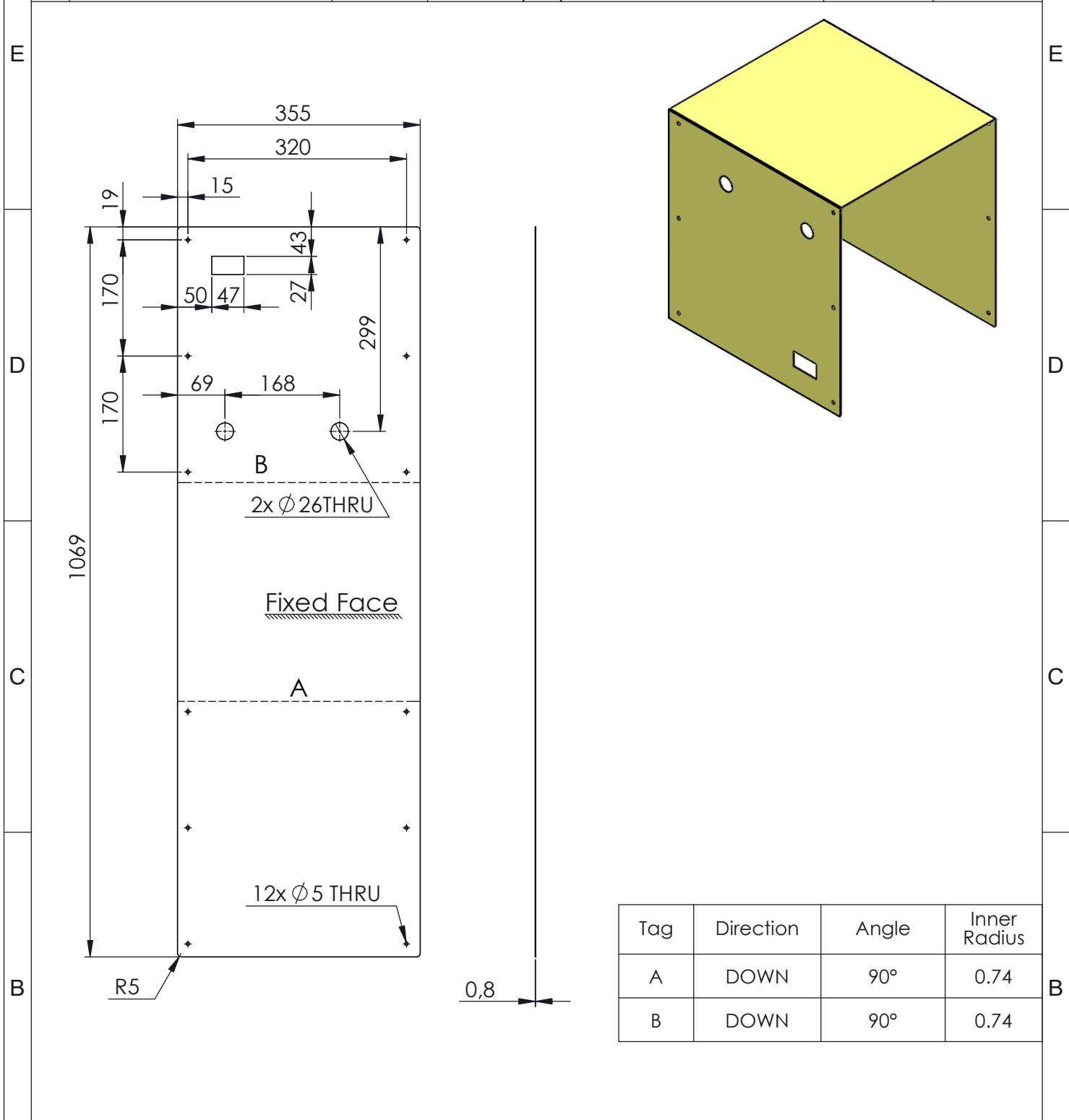

Tag	Direction	Angle	Inner Radius
A	DOWN	90°	0.74
B	DOWN	90°	0.74

>	0	6	30	120	400	1000	UKURAN LANJUT
<	6	30	120	400	1000	2000	
TOL	±0.1	±0.2	±0.3	±0.5	±0.8	±1.2	

NO. ORDER		PROYEKSI	

NAMA :

TOP-SIDE COVER

NO. ASSY. :

SKALA 1:8	DIGAMBAR	06-06-2022	IQBAL
	DIPERIKSA		
	DISAHKAN		

POLITEKNIK NEGERI CILACAP, JURUSAN TEKNIK MESIN
 JL. dr. SOETOMO, NO. 01, SIDAKAYA, CILACAP, 53212
 TELP : 0282 - 533329, E-mail : tmpnc@politeknikcilacap.ac.id

FORMAT A4	JTM19-01-02
---------------------	--------------------

5		4		3		2		1	
NO	PERUBAHAN	TANGGAL	NAMA	NO	PERUBAHAN	TANGGAL	NAMA		
				△					

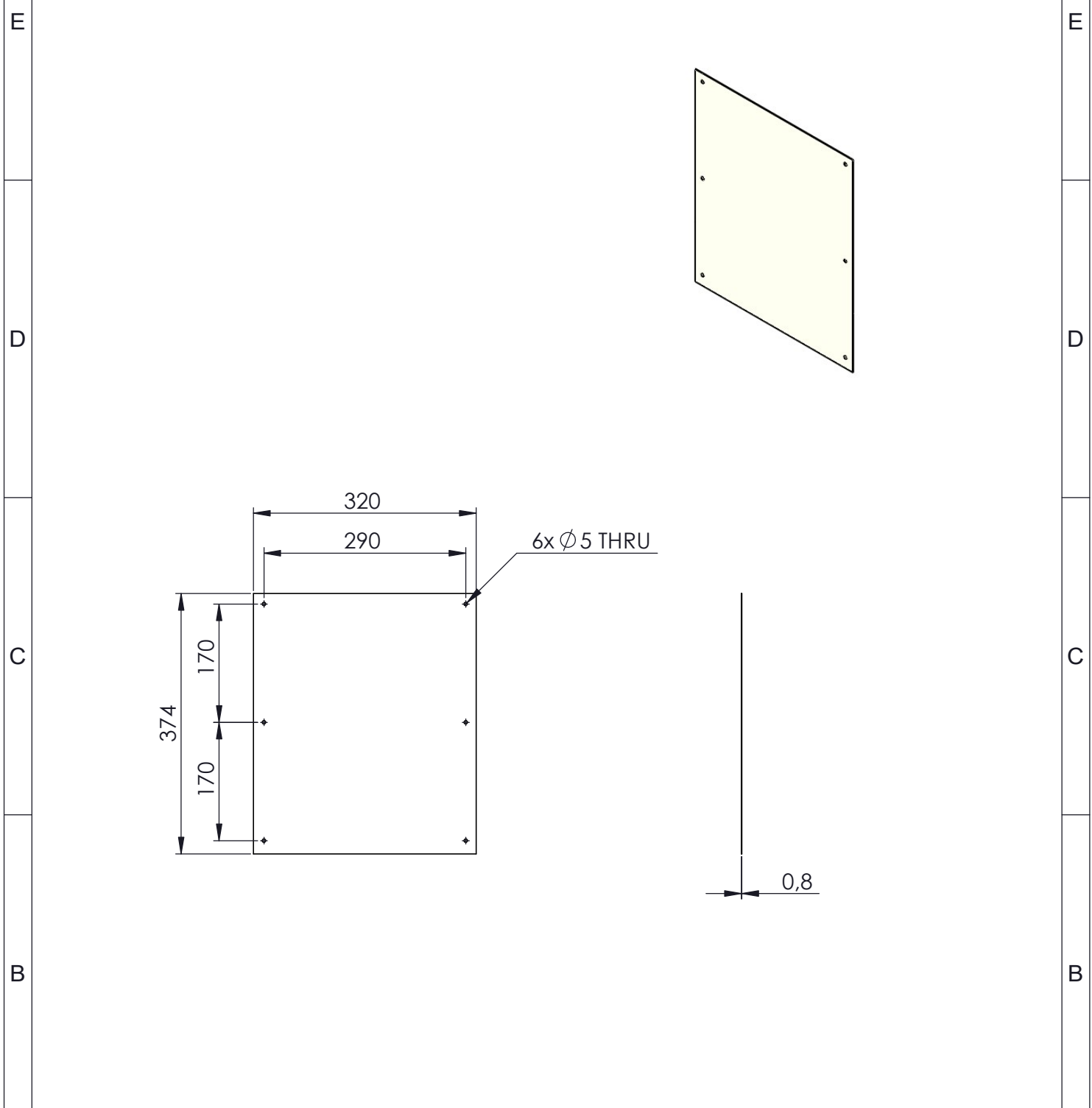

>	0	6	30	120	400	1000	UKURAN LANJUT	NO. ORDER	PROYEKSI		
<	6	30	120	400	1000	2000					
TOL	±0.1	±0.2	±0.3	±0.5	±0.8	±1.2			SKALA	DIGAMBAR	06-06-2022
NAMA :								1:8	DIPERIKSA		
<p style="text-align: center;">BACK COVER</p>									DISAHKAN		
NO. ASSY. :								FORMAT	JTM19-01-03		
POLITEKNIK NEGERI CILACAP, JURUSAN TEKNIK MESIN JL. dr. SOETOMO, NO. 01, SIDAKAYA, CILACAP, 53212 TELP : 0282 - 533329, E-mail : tmpnc@politeknikcilacap.ac.id								A4			

5	4	3	2	1
---	---	---	---	---

PERUBAHAN DARI :

DIGANTI DENGAN :

5		4		3		2		1	
NO	PERUBAHAN	TANGGAL	NAMA	NO	PERUBAHAN	TANGGAL	NAMA		
				△					

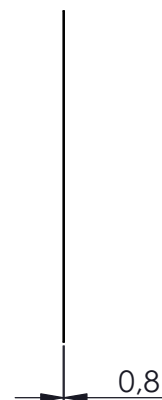
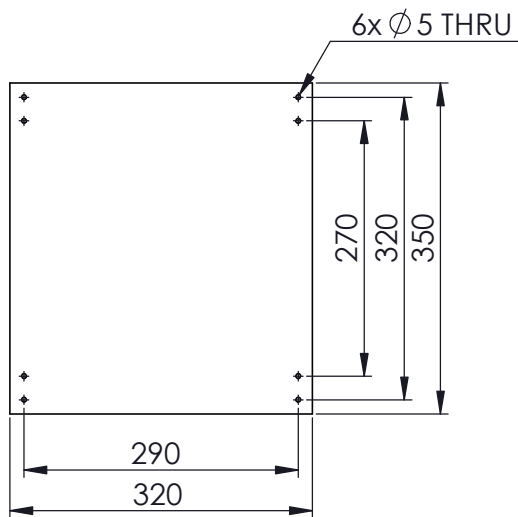
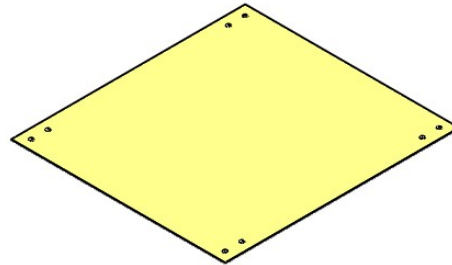

>	0	6	30	120	400	1000	UKURAN LANJUT
<	6	30	120	400	1000	2000	
TOL	±0.1	±0.2	±0.3	±0.5	±0.8	±1.2	

NO. ORDER		PROYEKSI	

NAMA :
BOTTOM COVER

NO. ASSY. :

SKALA 1:8	DIGAMBAR	06-06-2022	IQBAL
	DIPERIKSA		
	DISAHKAN		

POLITEKNIK NEGERI CILACAP, JURUSAN TEKNIK MESIN
 JL. dr. SOETOMO, NO. 01, SIDAKAYA, CILACAP, 53212
 TELP : 0282 - 533329, E-mail : tmpnc@politeknikcilacap.ac.id

FORMAT A4	JTM19-01-04
---------------------	--------------------

5		4		3		2		1	
---	--	---	--	---	--	---	--	---	--

PERUBAHAN DARI :

DIGANTI DENGAN :

5		4		3		2		1	
NO	PERUBAHAN	TANGGAL	NAMA	NO	PERUBAHAN	TANGGAL	NAMA		
				△					

E

E

D

D

C

C

B

B

A

A

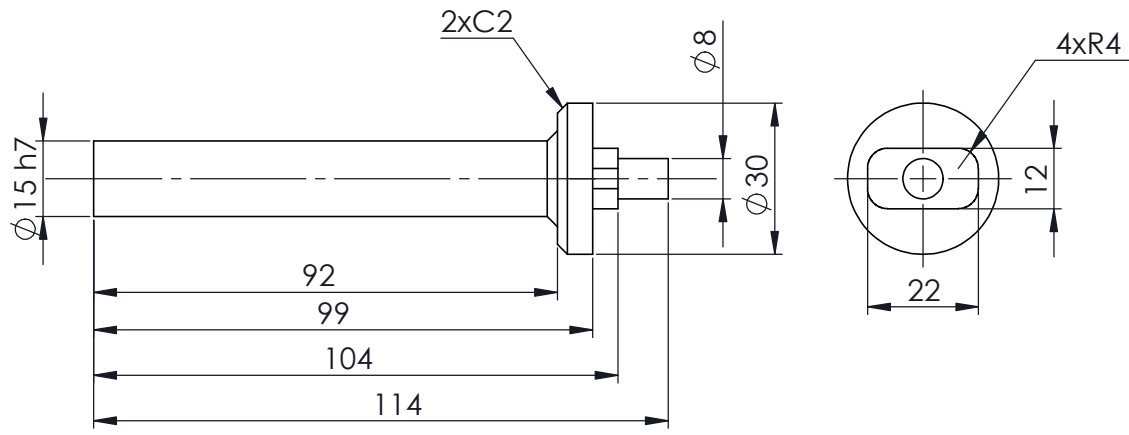
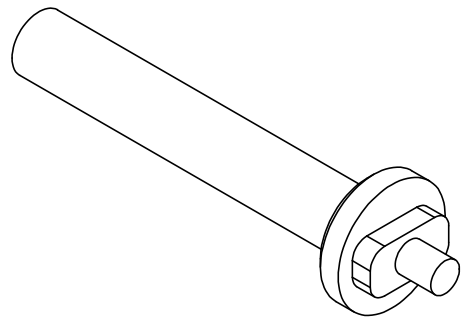

>	0	6	30	120	400	1000	UKURAN LANJUT
<	6	30	120	400	1000	2000	
TOL	±0.1	±0.2	±0.3	±0.5	±0.8	±1.2	

NO. ORDER		PROYEKSI	

NAMA :
SHAFT DRIVEN

NO. ASSY. :

SKALA 2:3	DIGAMBAR	06-06-2022	IQBAL
	DIPERIKSA		
	DISAHKAN		

POLITEKNIK NEGERI CILACAP, JURUSAN TEKNIK MESIN
 JL. dr. SOETOMO, NO. 01, SIDAKAYA, CILACAP, 53212
 TELP : 0282 - 533329, E-mail : tmpnc@politeknikcilacap.ac.id

FORMAT
A4

JTM19-01-05

5		4		3		2		1	
---	--	---	--	---	--	---	--	---	--

PERUBAHAN DARI :

DIGANTI DENGAN :

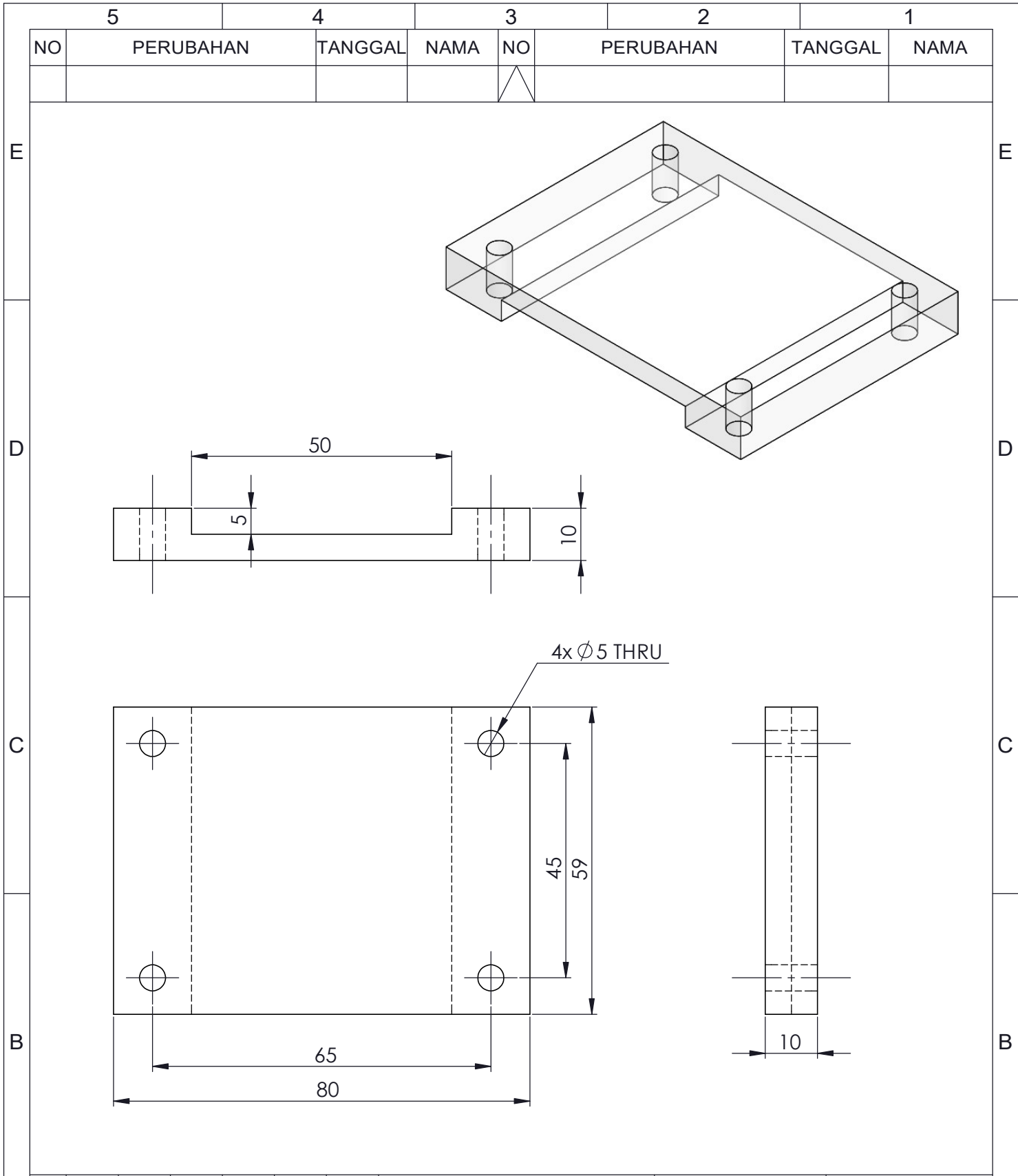

	>	0	6	30	120	400	1000	UKURAN LANJUT	NO. ORDER	PROYEKSI		
	<	6	30	120	400	1000	2000					
	TOL	±0.1	±0.2	±0.3	±0.5	±0.8	±1.2					
A	NAMA :								SKALA		DIGAMBAR	06-06-2022
	BASE DIMMER								1:1	DIPERIKSA		
	NO. ASSY. :								FORMAT	DISAHKAN		
POLITEKNIK NEGERI CILACAP, JURUSAN TEKNIK MESIN JL. dr. SOETOMO, NO. 01, SIDAKAYA, CILACAP, 53212 TELP : 0282 - 533329, E-mail : tmpnc@politeknikcilacap.ac.id								A4	JTM19-01-06			

5		4		3		2		1	
NO	PERUBAHAN	TANGGAL	NAMA	NO	PERUBAHAN	TANGGAL	NAMA		
				△					

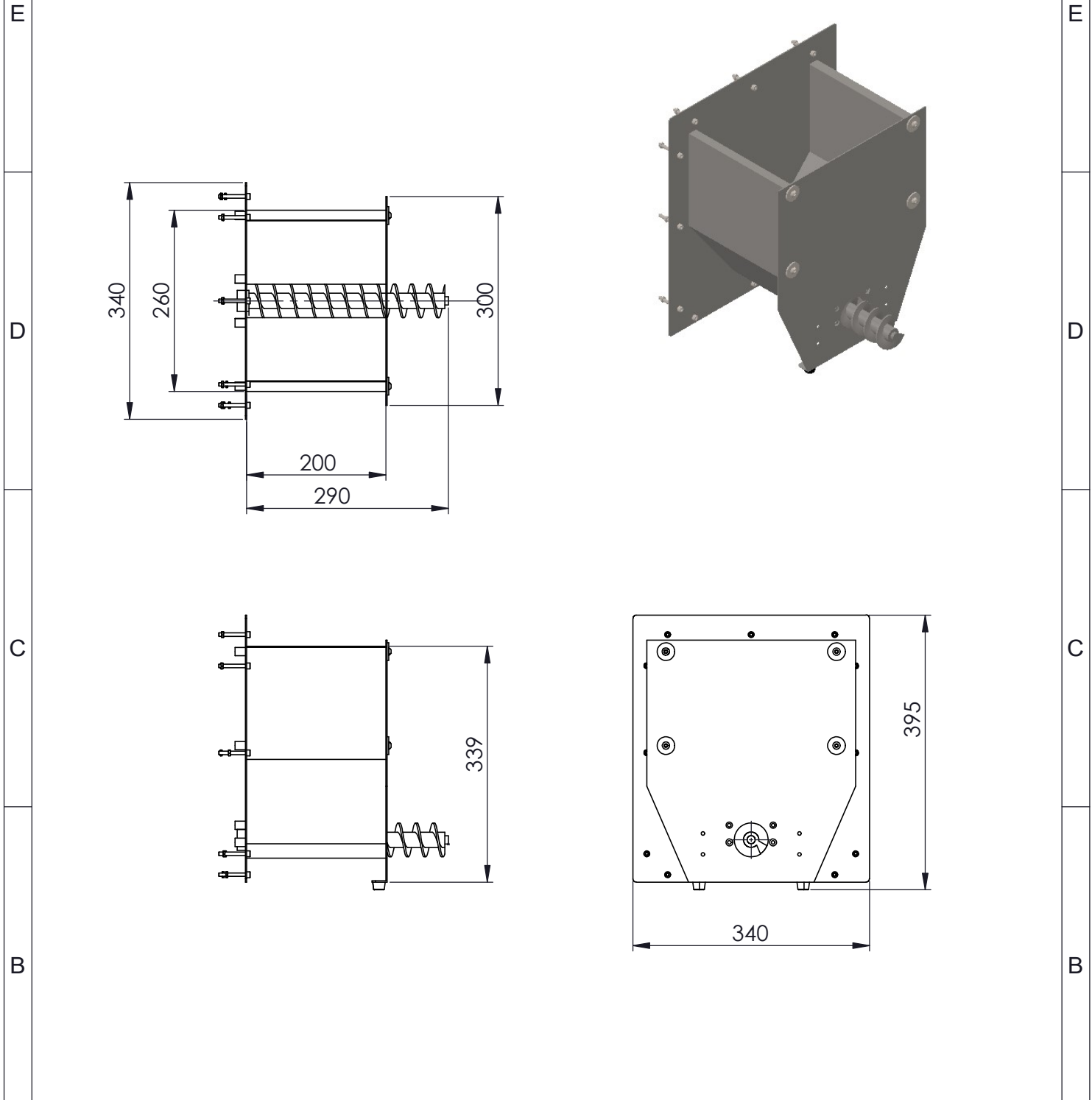

>	0	6	30	120	400	1000	UKURAN LANJUT
<	6	30	120	400	1000	2000	
TOL	±0.1	±0.2	±0.3	±0.5	±0.8	±1.2	

NO. ORDER		PROYEKSI	

NAMA :
EXTRUDER ASSY

NO. ASSY. :

SKALA 1:8	DIGAMBAR	06-06-2022	IQBAL
	DIPERIKSA		
	DISAHKAN		

POLITEKNIK NEGERI CILACAP, JURUSAN TEKNIK MESIN
 JL. dr. SOETOMO, NO. 01, SIDAKAYA, CILACAP, 53212
 TELP : 0282 - 533329, E-mail : tmpnc@politeknikcilacap.ac.id

FORMAT
A4

JTM19-02-00 (c)

5		4		3		2		1	
---	--	---	--	---	--	---	--	---	--

PERUBAHAN DARI :

DIGANTI DENGAN :

5		4			3		2		1	
NO	PERUBAHAN			TANGGAL	NAMA	NO	PERUBAHAN		TANGGAL	NAMA
						△				
E										
D										
C										
12	HEX NUT			9	STD	M5x0,8	-		-	
12	L HEX SHCS			8	STD	M5x0,8x40	-		-	
2	RUBBER FOOT			7	STD	-	-		-	
4	WASHER			6	STD	Ø6	-		-	
4	L HEX SBHCS			5	STD	M6x1x15	-		-	
1	COVER FRONT HOPPER			4	SS304	LIHAT DETAIL	-		JTM19-04-04	
1	BACK COVER HOPPER			3	SS304	LIHAT DETAIL	-		JTM19-03-03	
1	HOPPER			2	SS304	LIHAT DETAIL	-		JTM19-02-02	
1	SCREW EXTRUDER			1	SS304	LIHAT DETAIL	-		JTM19-02-01	
JML	NAMA BAGIAN			POS	BAHAN	UKURAN JADI	UKURAN KASAR		NO. ID	F
>	0	6	30	120	400	1000	UKURAN LANJUT		NO. ORDER	PROYEKSI 
<	6	30	120	400	1000	2000				
TOL	±0.1	±0.2	±0.3	±0.5	±0.8	±1.2				
NAMA :							SKALA	DIGAMBAR	06-06-2022	IQBAL
EXTRUDER ASSY							1:1	DIPERIKSA		
								DISAHKAN		
NO. ASSY. :							FORMAT	JTM19-02-00 (b)		
 POLITEKNIK NEGERI CILACAP, JURUSAN TEKNIK MESIN JL. dr. SOETOMO, NO. 01, SIDAKAYA, CILACAP, 53212 TELP : 0282 - 533329, E-mail : tmpnc@politeknikcilacap.ac.id							A4			
5		4			3		2		1	

PERUBAHAN DARI :

DIGANTI DENGAN :

5		4		3		2		1	
NO	PERUBAHAN	TANGGAL	NAMA	NO	PERUBAHAN	TANGGAL	NAMA		
				△					

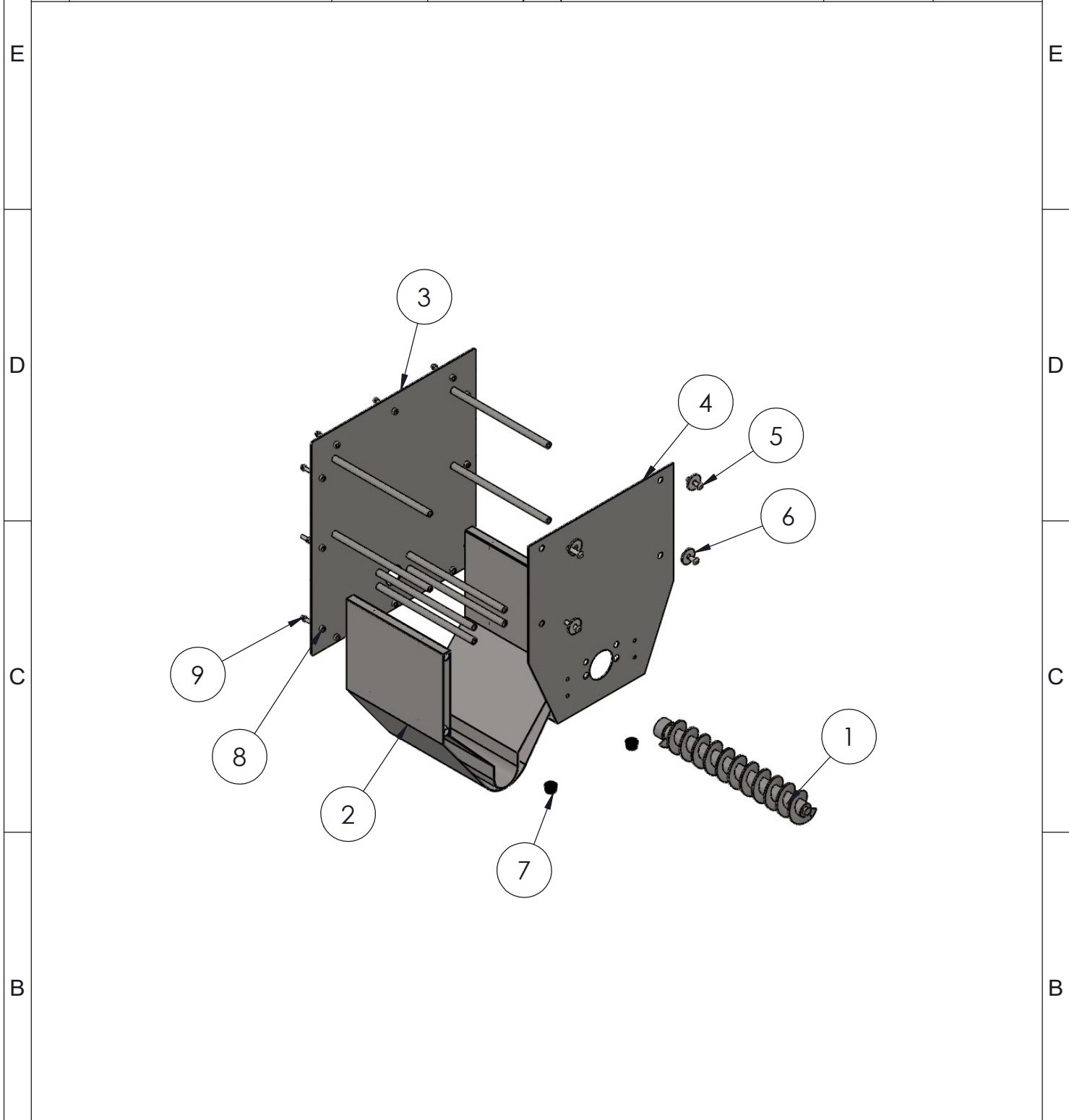

>	0	6	30	120	400	1000	UKURAN LANJUT	NO. ORDER	PROYEKSI		
<	6	30	120	400	1000	2000					
TOL	±0.1	±0.2	±0.3	±0.5	±0.8	±1.2					
NAMA :								SKALA	DIGAMBAR	06-06-2022	IQBAL
EXTRUDER ASSY								1:8	DIPERIKSA		
									DISAHKAN		
NO. ASSY. :								FORMAT	JTM19-02-00 (a)		
POLITEKNIK NEGERI CILACAP, JURUSAN TEKNIK MESIN JL. dr. SOETOMO, NO. 01, SIDAKAYA, CILACAP, 53212 TELP : 0282 - 533329, E-mail : tmpnc@politeknikcilacap.ac.id								A4			

PERUBAHAN DARI :

DIGANTI DENGAN :

5		4		3		2		1	
NO	PERUBAHAN	TANGGAL	NAMA	NO	PERUBAHAN	TANGGAL	NAMA		
				△					

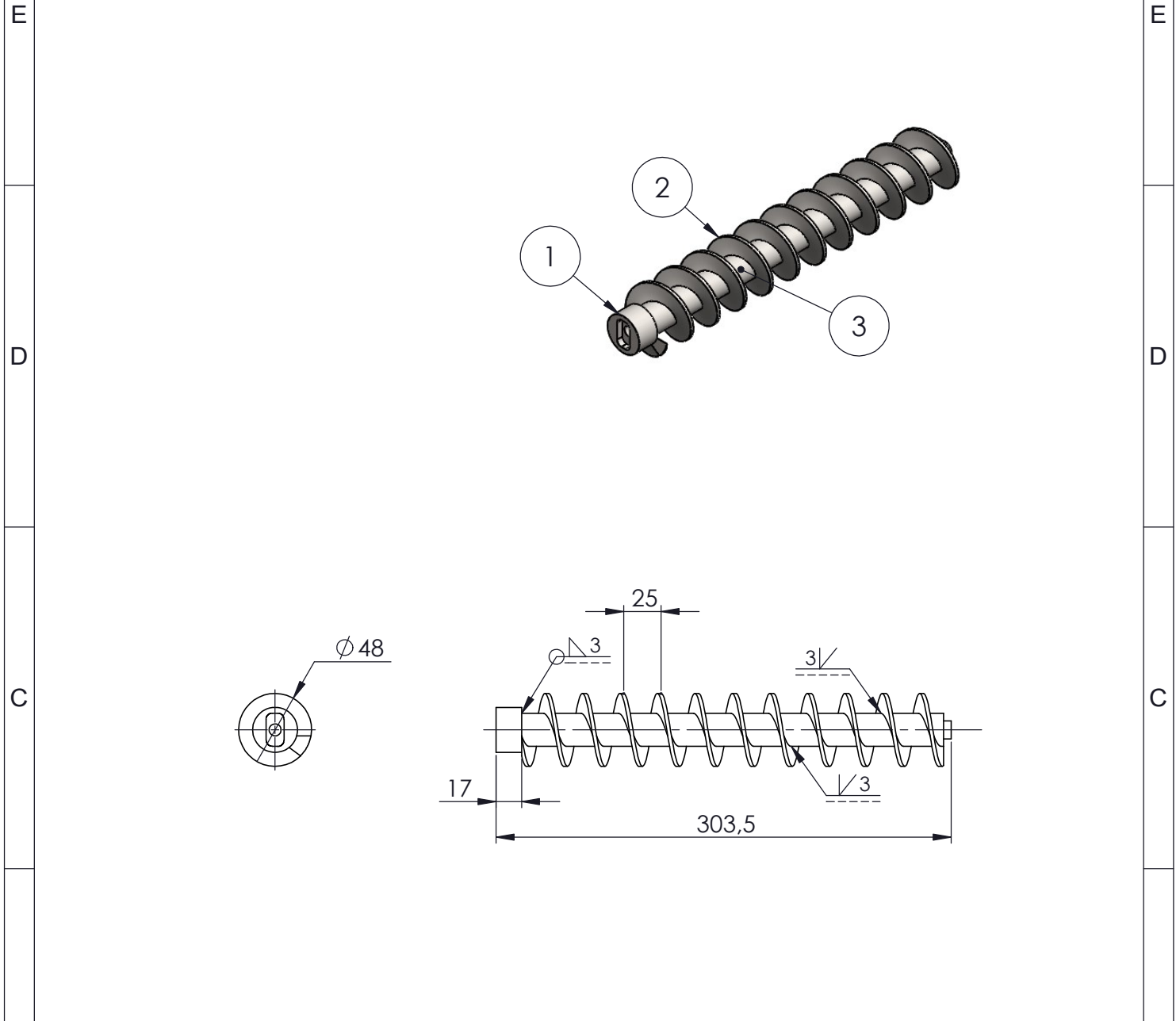

B	12	SCREW FLIGHT					3	SS304	LIHAT DETAIL	-	JTM19-01-03	B	
	1	SCREW SHAFT					2	SS304	LIHAT DETAIL	-	JTM19-01-02		
	1	SCREW HUB					1	SS304	LIHAT DETAIL	-	JTM19-01-01		
JML	NAMA BAGIAN					POS	BAHAN	UKURAN JADI	UKURAN KASAR	NO. ID	F		
>	0	6	30	120	400	1000	UKURAN LANJUT		NO. ORDER	PROYEKSI			
<	6	30	120	400	1000	2000							
TOL	±0.1	±0.2	±0.3	±0.5	±0.8	±1.2							
A	NAMA : <h2 style="text-align: center;">SCREW EXTRUDER</h2>								SKALA	DIGAMBAR	06-06-2022	IQBAL	A
	NO. ASSY. :								1:4	DIPERIKSA			
									DISAHKAN				
	POLITEKNIK NEGERI CILACAP, JURUSAN TEKNIK MESIN JL. dr. SOETOMO, NO. 01, SIDAKAYA, CILACAP, 53212 TELP : 0282 - 533329, E-mail : tmpnc@politeknikcilacap.ac.id								FORMAT	JTM19-02-01-00			
	5		4		3		2		1				

5		4		3		2		1	
NO	PERUBAHAN	TANGGAL	NAMA	NO	PERUBAHAN	TANGGAL	NAMA		
				△					

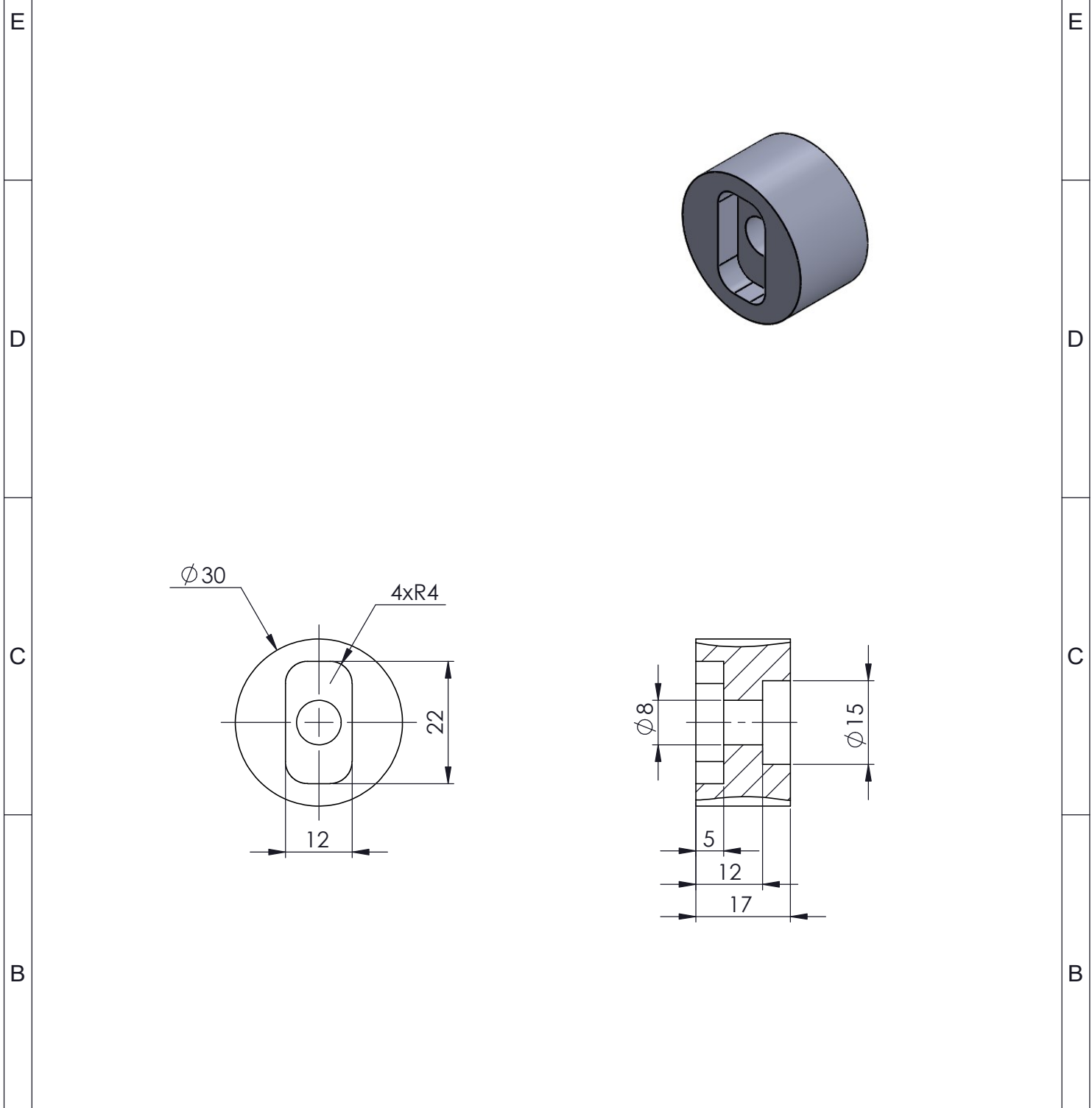

>	0	6	30	120	400	1000	UKURAN LANJUT	NO. ORDER	PROYEKSI		
<	6	30	120	400	1000	2000					
TOL	±0.1	±0.2	±0.3	±0.5	±0.8	±1.2					
NAMA :								SKALA	DIGAMBAR	06-06-2022	IQBAL
SCREW HUB								1:1	DIPERIKSA		
									DISAHKAN		
NO. ASSY. :									FORMAT	JTM19-02-01-01	
POLITEKNIK NEGERI CILACAP, JURUSAN TEKNIK MESIN JL. dr. SOETOMO, NO. 01, SIDAKAYA, CILACAP, 53212 TELP : 0282 - 533329, E-mail : tmpnc@politeknikcilacap.ac.id								A4			

5		4		3		2		1	
NO	PERUBAHAN	TANGGAL	NAMA	NO	PERUBAHAN	TANGGAL	NAMA		
				△					

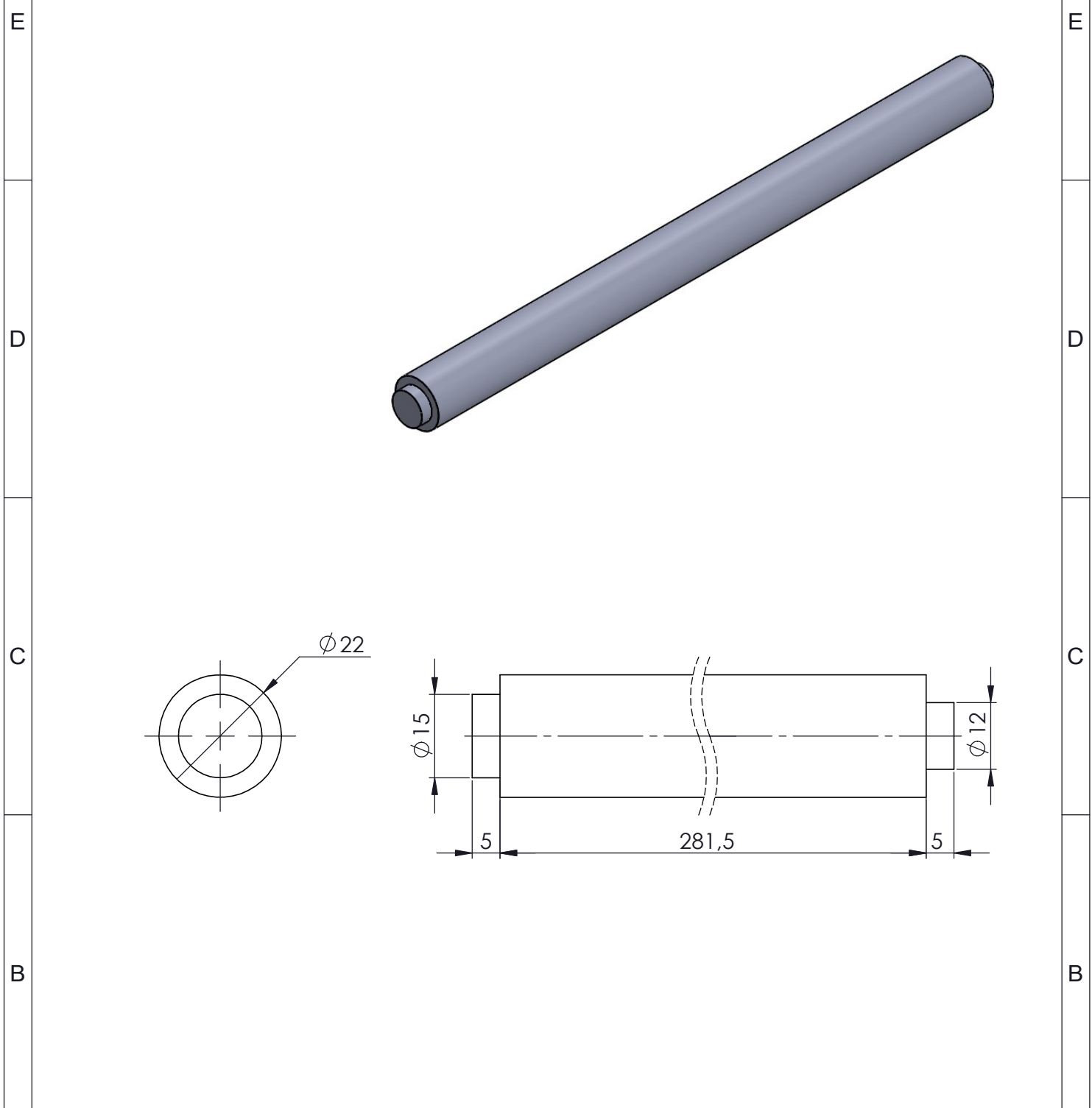

>	0	6	30	120	400	1000	UKURAN LANJUT	NO. ORDER	PROYEKSI		
<	6	30	120	400	1000	2000					
TOL	±0.1	±0.2	±0.3	±0.5	±0.8	±1.2					
NAMA :								SKALA	DIGAMBAR	06-06-2022	IQBAL
SCREW SHAFT								1:1	DIPERIKSA		
									DISAHKAN		
NO. ASSY. :								FORMAT	JTM19-02-01-02		
POLITEKNIK NEGERI CILACAP, JURUSAN TEKNIK MESIN JL. dr. SOETOMO, NO. 01, SIDAKAYA, CILACAP, 53212 TELP : 0282 - 533329, E-mail : tmpnc@politeknikcilacap.ac.id								A4			

5		4		3		2		1	
NO	PERUBAHAN	TANGGAL	NAMA	NO	PERUBAHAN	TANGGAL	NAMA		
				△					

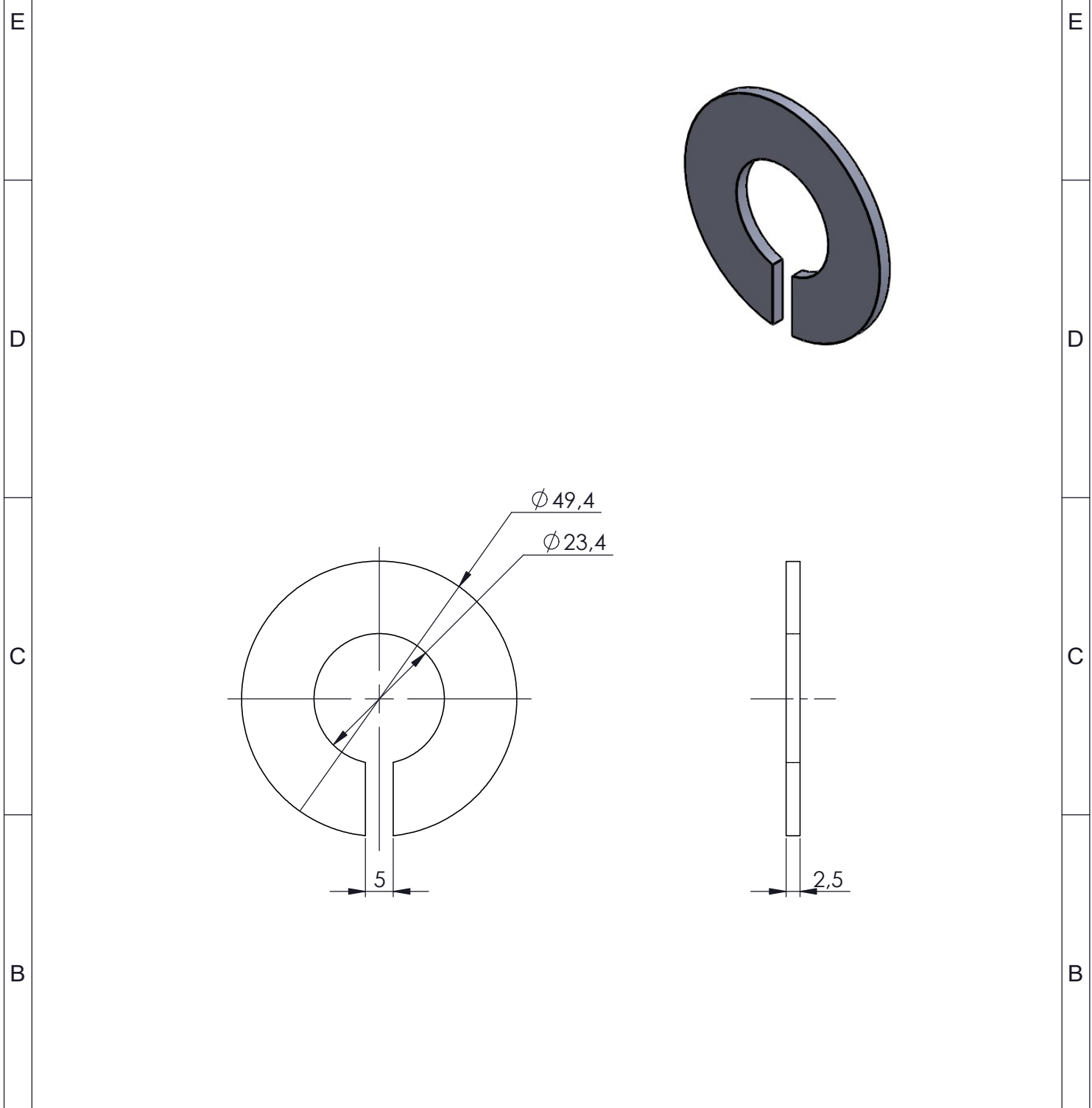

>	0	6	30	120	400	1000	UKURAN LANJUT	NO. ORDER	PROYEKSI				
<	6	30	120	400	1000	2000				SKALA	DIGAMBAR	06-06-2022	IQBAL
TOL	±0.1	±0.2	±0.3	±0.5	±0.8	±1.2					1:1	DIPERIKSA	
NAMA :								FORMAT	JTM19-02-01-03				
SCREW FLIGHT									A4				
NO. ASSY. :								POLITEKNIK NEGERI CILACAP, JURUSAN TEKNIK MESIN					
								JL. dr. SOETOMO, NO. 01, SIDAKAYA, CILACAP, 53212					
								TELP : 0282 - 533329, E-mail : tmpnc@politeknikcilacap.ac.id					

PERUBAHAN DARI :

DIGANTI DENGAN :

5		4		3		2		1	
NO	PERUBAHAN	TANGGAL	NAMA	NO	PERUBAHAN	TANGGAL	NAMA		
				△					

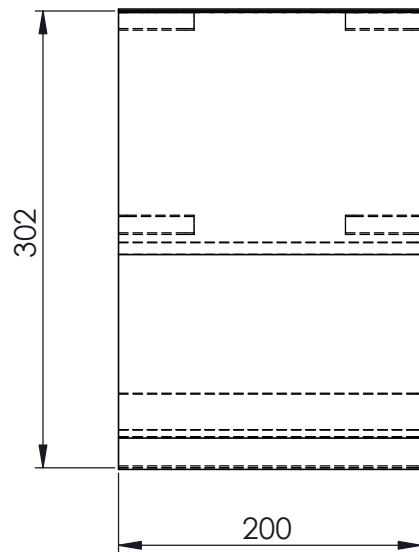
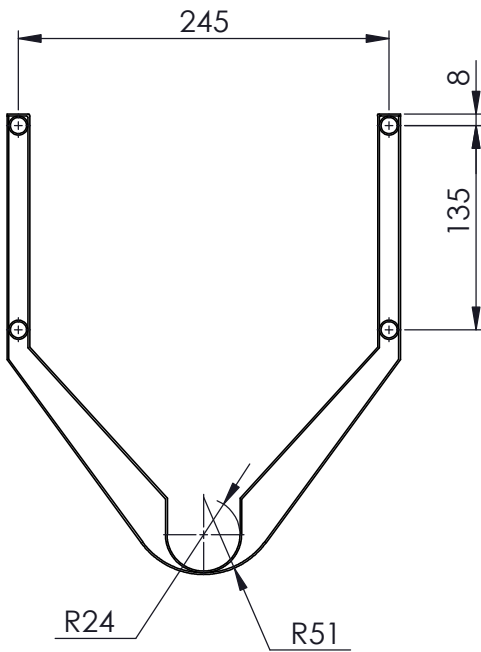
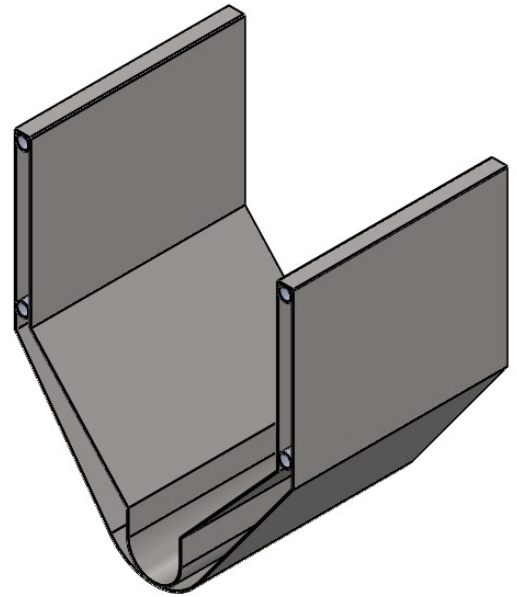
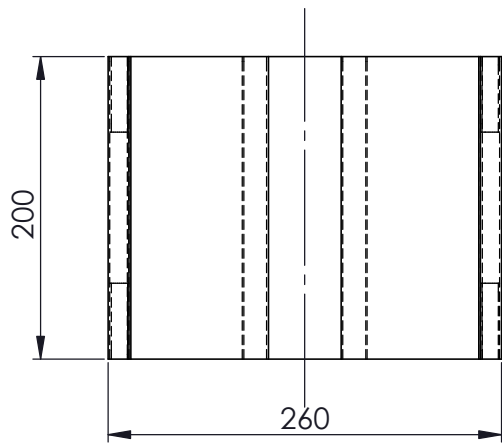

>	0	6	30	120	400	1000	UKURAN LANJUT
<	6	30	120	400	1000	2000	
TOL	±0.1	±0.2	±0.3	±0.5	±0.8	±1.2	

NO. ORDER

PROYEKSI

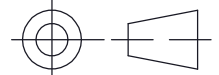

NAMA :

HOPPER

SKALA

DIGAMBAR

06-06-2022

IQBAL

1:8

DIPERIKSA

DISAHKAN

NO. ASSY. :

FORMAT

A4



JTM19-02-02-00 (b)

POLITEKNIK NEGERI CILACAP, JURUSAN TEKNIK MESIN
 JL. dr. SOETOMO, NO. 01, SIDAKAYA, CILACAP, 53212
 TELP : 0282 - 533329, E-mail : tmpnc@politeknikcilacap.ac.id

5		4		3		2		1	
---	--	---	--	---	--	---	--	---	--

PERUBAHAN DARI :

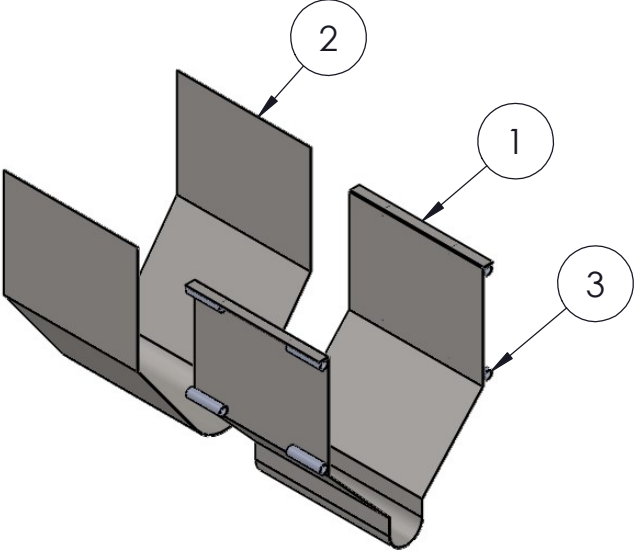
DIGANTI DENGAN :

5		4			3		2		1		
NO	PERUBAHAN			TANGGAL	NAMA	NO	PERUBAHAN		TANGGAL	NAMA	
						△					
											
8	GUIDE			3	SS304	LIHAT DETAIL		-	JTM19-02-02-03		
1	COVER HOPPER			2	SS304	LIHAT DETAIL		-	JTM19-02-02-02		
1	HOPPER 01			1	SS304	LIHAT DETAIL		-	JTM19-02-02-01		
JML	NAMA BAGIAN			POS	BAHAN	UKURAN JADI		UKURAN KASAR		NO. ID	
>	0	6	30	120	400	1000	UKURAN LANJUT		NO. ORDER		
<	6	30	120	400	1000	2000					
TOL	±0.1	±0.2	±0.3	±0.5	±0.8	±1.2					
NAMA :							SKALA		DIGAMBAR	06-06-2022	IQBAL
HOPPER							1:8		DIPERIKSA		
									DISAHKAN		
NO. ASSY. :							FORMAT		JTM19-02-02-00 (a)		
		POLITEKNIK NEGERI CILACAP, JURUSAN TEKNIK MESIN JL. dr. SOETOMO, NO. 01, SIDAKAYA, CILACAP, 53212 TELP : 0282 - 533329, E-mail : tmpnc@politeknikcilacap.ac.id					A4				

5		4		3		2		1	
NO	PERUBAHAN	TANGGAL	NAMA	NO	PERUBAHAN	TANGGAL	NAMA		
				△					

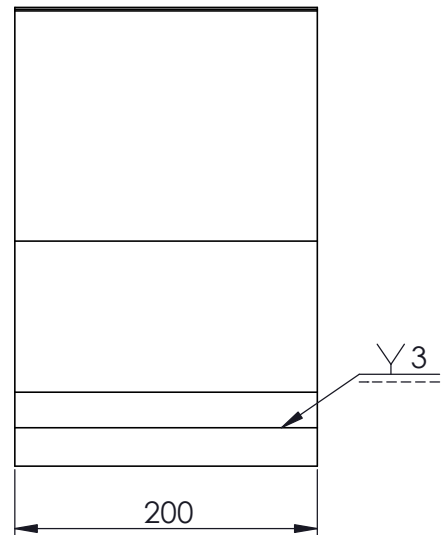
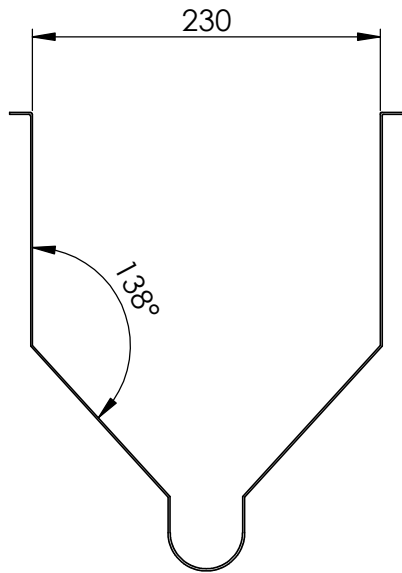
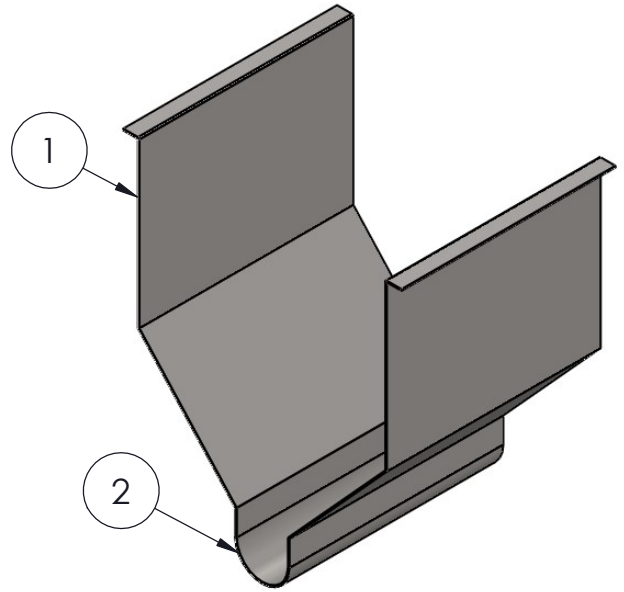

1	HOPPER 02					2	SS304	LIHAT DETAIL	-	JTM19-02-02-01-02
2	HOPPER 01					1	SS304	LIHAT DETAIL	-	JTM19-02-02-01-01
JML	NAMA BAGIAN					POS	BAHAN	UKURAN JADI	UKURAN KASAR	NO. ID
>	0	6	30	120	400	1000	UKURAN LANJUT		NO. ORDER	PROYEKSI
<	6	30	120	400	1000	2000				
TOL	±0.1	±0.2	±0.3	±0.5	±0.8	±1.2				

NAMA :								SKALA	DIGAMBAR	06-06-2022	IQBAL
HOPPER								1:5	DIPERIKSA		
									DISAHKAN		

NO. ASSY. :								FORMAT	JTM19-02-02-01		
POLITEKNIK NEGERI CILACAP, JURUSAN TEKNIK MESIN JL. dr. SOETOMO, NO. 01, SIDAKAYA, CILACAP, 53212 TELP : 0282 - 533329, E-mail : tmpnc@politeknikcilacap.ac.id								A4			

5		4		3		2		1	
---	--	---	--	---	--	---	--	---	--

PERUBAHAN DARI :

DIGANTI DENGAN :

	5	4	3	2	1		
NO	PERUBAHAN	TANGGAL	NAMA	NO	PERUBAHAN	TANGGAL	NAMA
				△			

E
E

D
D

C
C

B
B

A
A

5
4
3
2
1

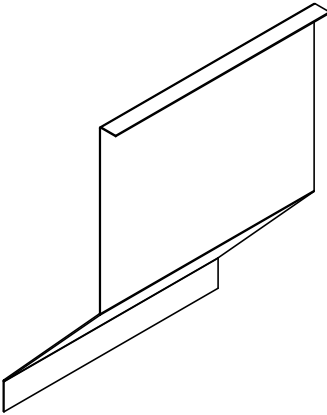

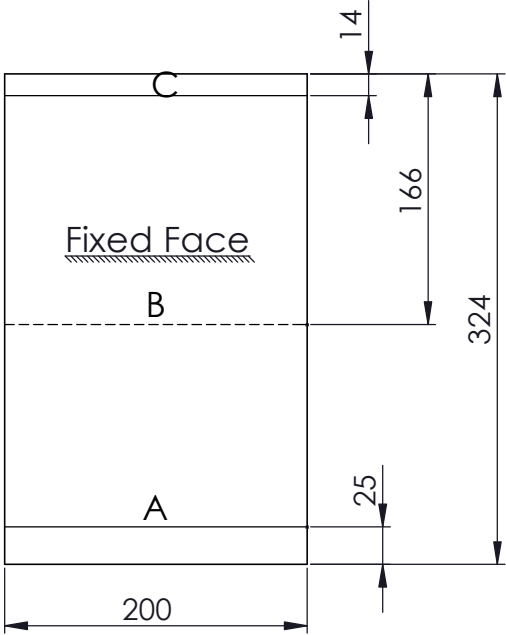

Tag	Direction	Angle	Inner Radius
A	UP	42.3°	0.74
B	DOWN	42.3°	0.74
C	UP	90°	0.74

>	0	6	30	120	400	1000	UKURAN LANJUT
<	6	30	120	400	1000	2000	
TOL	±0.1	±0.2	±0.3	±0.5	±0.8	±1.2	

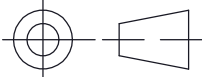
NO. ORDER		PROYEKSI	
			
SKALA 1:5	DIGAMBAR	06-06-2022	IQBAL
	DIPERIKSA		
	DISAHKAN		

NAMA :							
HOPPER 01							
NO. ASSY. :							

FORMAT A4	JTM19-02-02-01-01		
---------------------	-------------------	--	--

 POLITEKNIK NEGERI CILACAP, JURUSAN TEKNIK MESIN JL. dr. SOETOMO, NO. 01, SIDAKAYA, CILACAP, 53212 TELP : 0282 - 533329, E-mail : tmpnc@politeknikcilacap.ac.id							
--	--	--	--	--	--	--	--

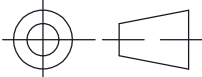
NO. ORDER		PROYEKSI	
			
SKALA 1:5	DIGAMBAR	06-06-2022	IQBAL
	DIPERIKSA		
	DISAHKAN		



5
4
3
2
1

PERUBAHAN DARI :
DIGANTI DENGAN :

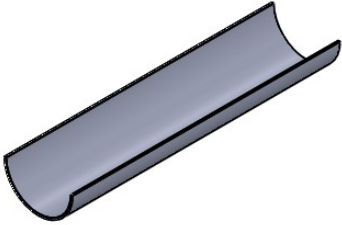
5		4			3		2			1	
NO	PERUBAHAN			TANGGAL	NAMA	NO	PERUBAHAN			TANGGAL	NAMA
						△					

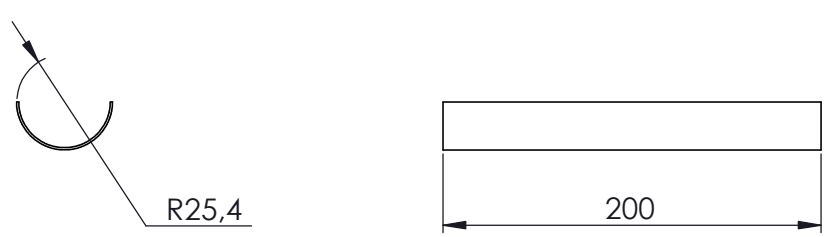



>	0	6	30	120	400	1000	UKURAN LANJUT	NO. ORDER	PROYEKSI		
<	6	30	120	400	1000	2000					
TOL	±0.1	±0.2	±0.3	±0.5	±0.8	±1.2					
NAMA : HOPPER 02								SKALA 1:4	DIGAMBAR 06-06-2022	DIPERIKSA	IQBAL
NO. ASSY. :								DISAHKAN			
 POLITEKNIK NEGERI CILACAP, JURUSAN TEKNIK MESIN JL. dr. SOETOMO, NO. 01, SIDAKAYA, CILACAP, 53212 TELP : 0282 - 533329, E-mail : tmpnc@politeknikcilacap.ac.id								FORMAT A4	JTM19-02-02-01-02		

PERUBAHAN DARI :

DIGANTI DENGAN :

5		4		3		2		1	
NO	PERUBAHAN	TANGGAL	NAMA	NO	PERUBAHAN	TANGGAL	NAMA		
				△					

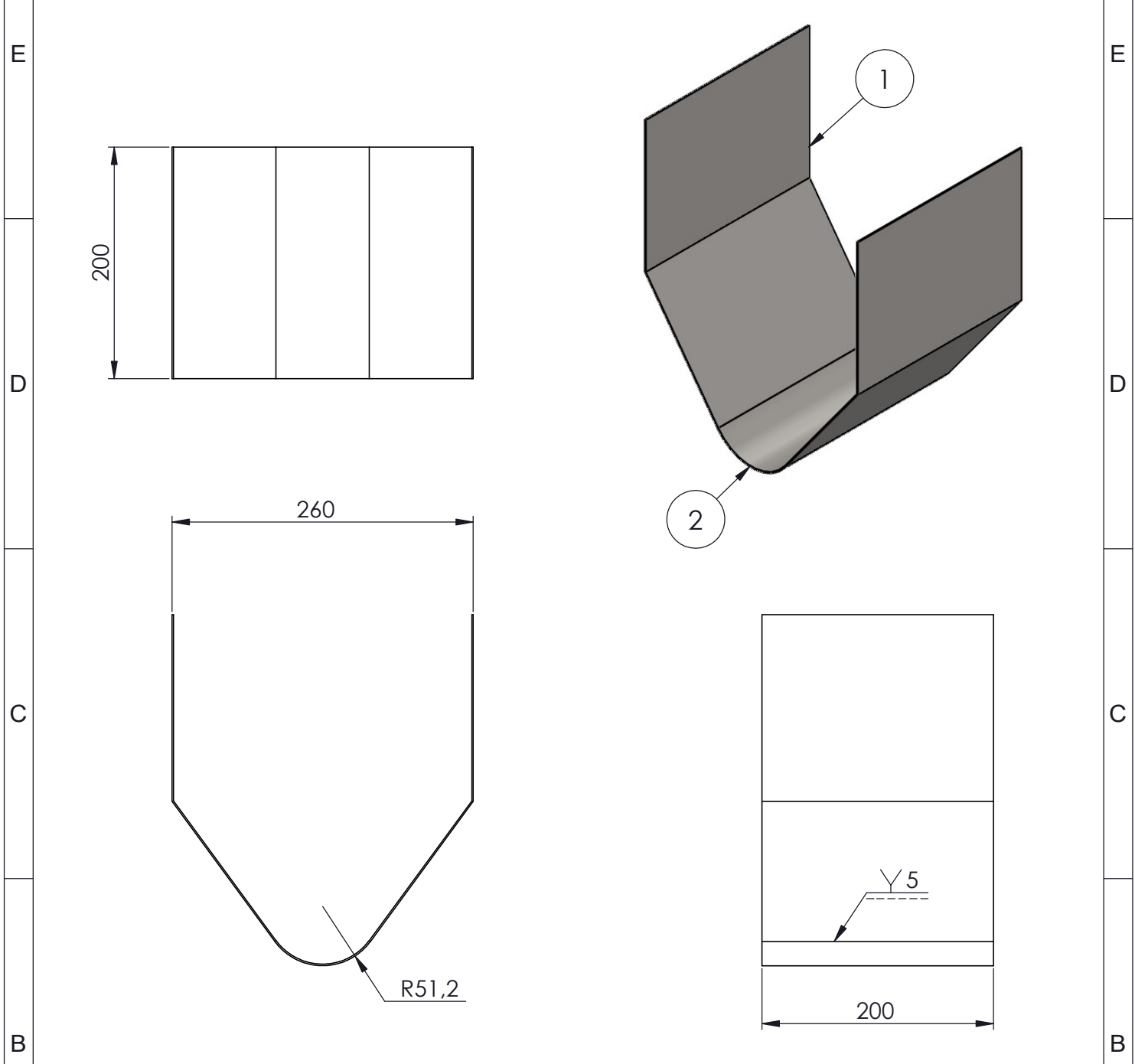

1	COVER HOPPER 02	2	SS304	LIHAT DETAIL	-	JTM19-02-02-02-02			
1	COVER HOPPER 01	1	SS304	LIHAT DETAIL	-	JTM19-02-02-02-01			
JML	NAMA BAGIAN	POS	BAHAN	UKURAN JADI	UKURAN KASAR	NO. ID	F		
>	0	6	30	120	400	1000	UKURAN LANJUT		
<	6	30	120	400	1000	2000			
TOL	±0.1	±0.2	±0.3	±0.5	±0.8	±1.2			
NAMA :					SKALA	DIGAMBAR	06-06-2022	IQBAL	
COVER HOPPER					1:5	DIPERIKSA			
						DISAHKAN			
NO. ASSY. :					FORMAT	JTM19-02-02-02-00			
 POLITEKNIK NEGERI CILACAP, JURUSAN TEKNIK MESIN JL. dr. SOETOMO, NO. 01, SIDAKAYA, CILACAP, 53212 TELP : 0282 - 533329, E-mail : tmpnc@politeknikcilacap.ac.id					A4				
5		4		3		2		1	

PERUBAHAN DARI :

DIGANTI DENGAN :

	5	4	3	2	1		
NO	PERUBAHAN	TANGGAL	NAMA	NO	PERUBAHAN	TANGGAL	NAMA
				△			

E
E

D
D

C
C

B
B

A
A

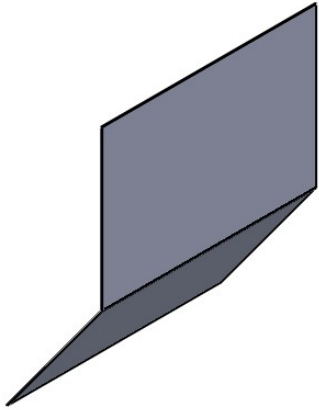

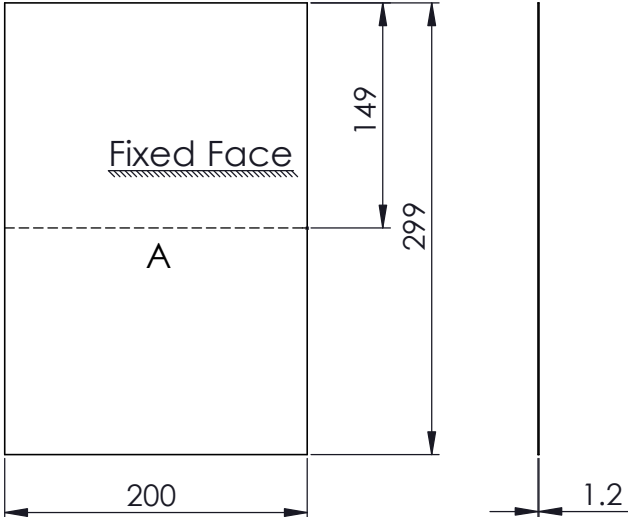

Tag	Direction	Angle	Inner Radius
A	DOWN	36.25°	0.74

	>	0	6	30	120	400	1000	UKURAN LANJUT	NO. ORDER	PROYEKSI
	<	6	30	120	400	1000	2000			
TOL	±0.1	±0.2	±0.3	±0.5	±0.8	±1.2				

NAMA : <h2 style="text-align: center;">COVER HOPPER 01</h2>	SKALA <h2 style="text-align: center;">1:5</h2>	DIGAMBAR 06-06-2022 DIPERIKSA DISAHKAN	IQBAL
--	---	---	-------

NO. ASSY. :  POLITEKNIK NEGERI CILACAP, JURUSAN TEKNIK MESIN JL. dr. SOETOMO, NO. 01, SIDAKAYA, CILACAP, 53212 TELP : 0282 - 533329, E-mail : tmpnc@politeknikcilacap.ac.id	FORMAT <h2 style="text-align: center;">A4</h2>	<h2 style="font-size: 1.2em;">JTM19-02-02-02-01</h2>
---	---	--

5	4	3	2	1
---	---	---	---	---

PERUBAHAN DARI :
DIGANTI DENGAN :

5		4			3		2		1	
NO	PERUBAHAN	TANGGAL	NAMA	NO	PERUBAHAN	TANGGAL	NAMA			
				△						

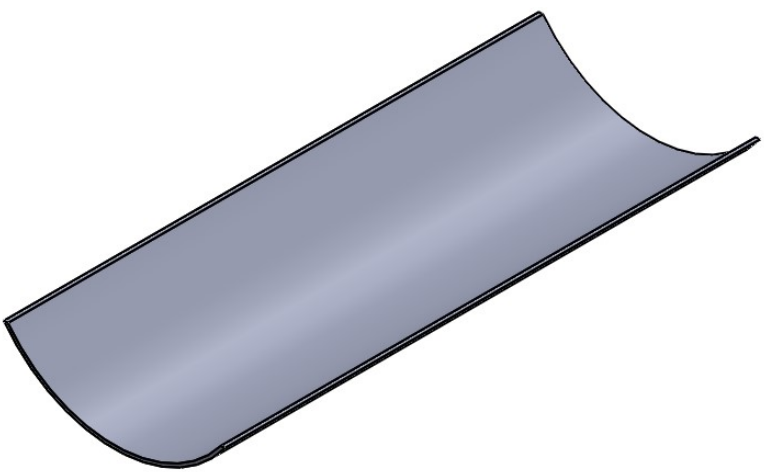

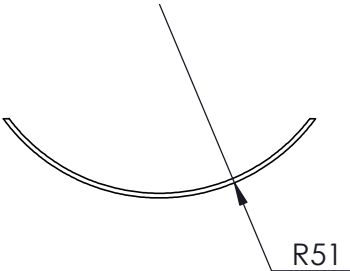

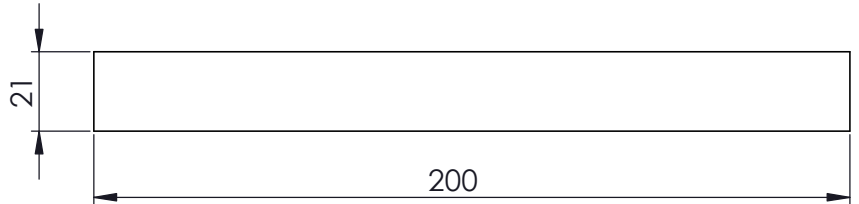

R51

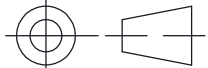

21

200

>	0	6	30	120	400	1000	UKURAN LANJUT	NO. ORDER	PROYEKSI		
<	6	30	120	400	1000	2000					
TOL	±0.1	±0.2	±0.3	±0.5	±0.8	±1.2					
NAMA :								SKALA	DIGAMBAR	06-06-2022	IQBAL
COVER HOPPER 02								1:2	DIPERIKSA		
NO. ASSY. :								DISAHKAN			
 POLITEKNIK NEGERI CILACAP, JURUSAN TEKNIK MESIN JL. dr. SOETOMO, NO. 01, SIDAKAYA, CILACAP, 53212 TELP : 0282 - 533329, E-mail : tmpnc@politeknikcilacap.ac.id								FORMAT	JTM19-02-02-02-02		
5								4	3	2	1

PERUBAHAN DARI :

DIGANTI DENGAN :

5		4		3		2		1																								
NO	PERUBAHAN	TANGGAL	NAMA	NO	PERUBAHAN	TANGGAL	NAMA																									
				△																												
<table border="1"> <tr> <td>></td> <td>0</td> <td>6</td> <td>30</td> <td>120</td> <td>400</td> <td>1000</td> <td rowspan="3">UKURAN LANJUT</td> <td rowspan="3">NO. ORDER</td> <td rowspan="3">PROYEKSI</td> </tr> <tr> <td><</td> <td>6</td> <td>30</td> <td>120</td> <td>400</td> <td>1000</td> <td>2000</td> </tr> <tr> <td>TOL</td> <td>±0.1</td> <td>±0.2</td> <td>±0.3</td> <td>±0.5</td> <td>±0.8</td> <td>±1.2</td> </tr> </table>							>	0	6	30	120	400	1000	UKURAN LANJUT	NO. ORDER	PROYEKSI	<	6	30	120	400	1000	2000	TOL	±0.1	±0.2	±0.3	±0.5	±0.8	±1.2		
>	0	6	30	120	400	1000	UKURAN LANJUT	NO. ORDER	PROYEKSI																							
<	6	30	120	400	1000	2000																										
TOL	±0.1	±0.2	±0.3	±0.5	±0.8	±1.2																										
<p>NAMA :</p> <p style="text-align: center;">GUIDE</p> <p>NO. ASSY. :</p>							SKALA	DIGAMBAR	06-06-2022	IQBAL																						
							1:1	DIPERIKSA																								
								DISAHKAN																								
<p>POLITEKNIK NEGERI CILACAP, JURUSAN TEKNIK MESIN JL. dr. SOETOMO, NO. 01, SIDAKAYA, CILACAP, 53212 TELP : 0282 - 533329, E-mail : tmpnc@politeknikcilacap.ac.id</p>							FORMAT	JTM19-02-02-03																								
5		4		3		2		1																								

PERUBAHAN DARI :

DIGANTI DENGAN :

5		4		3		2		1	
NO	PERUBAHAN	TANGGAL	NAMA	NO	PERUBAHAN	TANGGAL	NAMA		
				△					

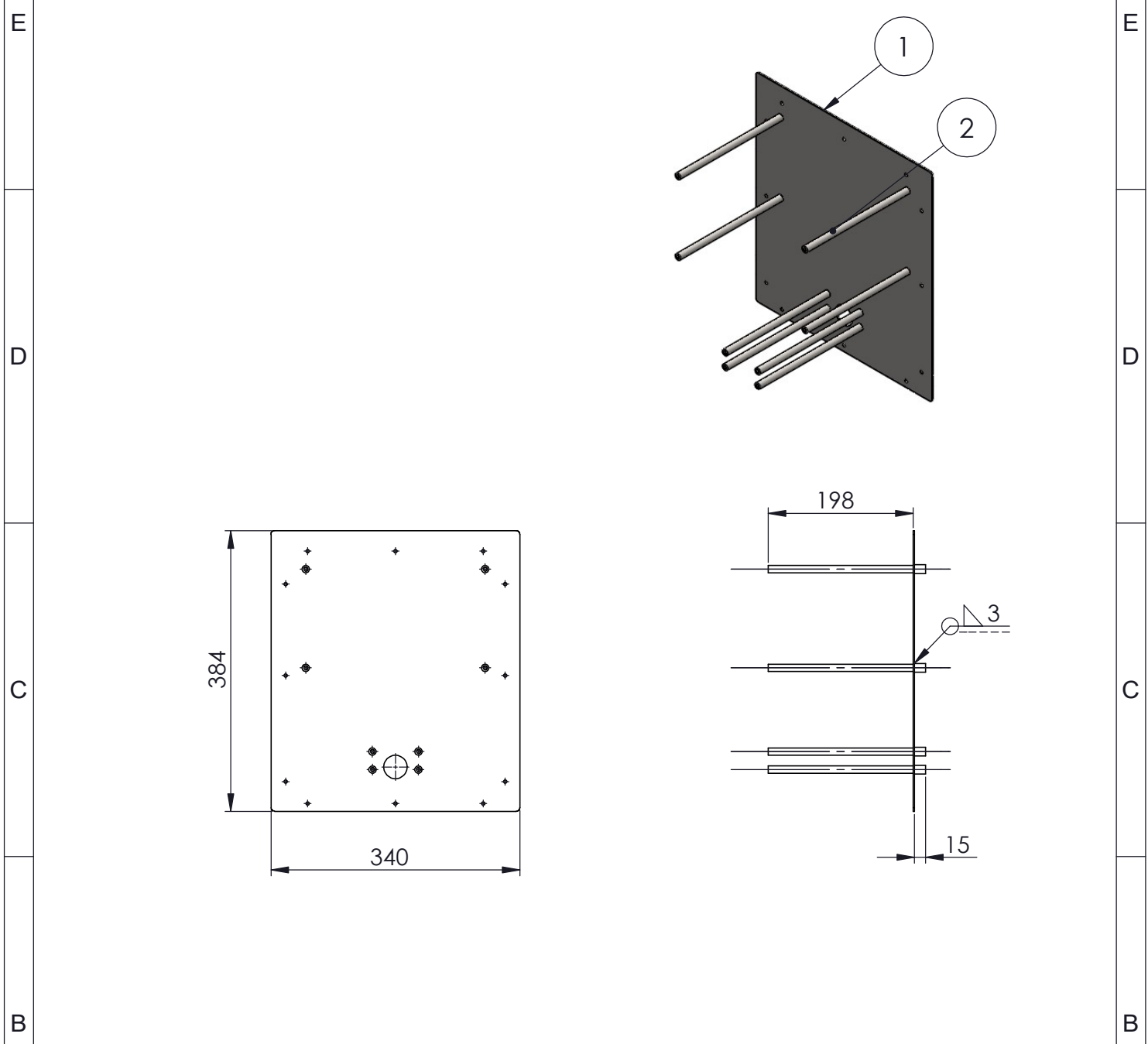

8	HOPPER FRAME					2	SS304	LIHAT DETAIL	-	JTM19-02-03-02
1	BACK HOPPER					1	SS304	LIHAT DETAIL	-	JTM19-02-03-01
JML	NAMA BAGIAN					POS	BAHAN	UKURAN JADI	UKURAN KASAR	NO. ID
>	0	6	30	120	400	1000	UKURAN LANJUT		NO. ORDER	PROYEKSI
<	6	30	120	400	1000	2000				
TOL	±0.1	±0.2	±0.3	±0.5	±0.8	±1.2				
NAMA :								SKALA	DIGAMBAR	06-06-2022
BACK COVER HOPPER								1:8	DIPERIKSA	
									DISAHKAN	
NO. ASSY. :								FORMAT	JTM19-02-03-00	
POLITEKNIK NEGERI CILACAP, JURUSAN TEKNIK MESIN JL. dr. SOETOMO, NO. 01, SIDAKAYA, CILACAP, 53212 TELP : 0282 - 533329, E-mail : tmpnc@politeknikcilacap.ac.id								A4		

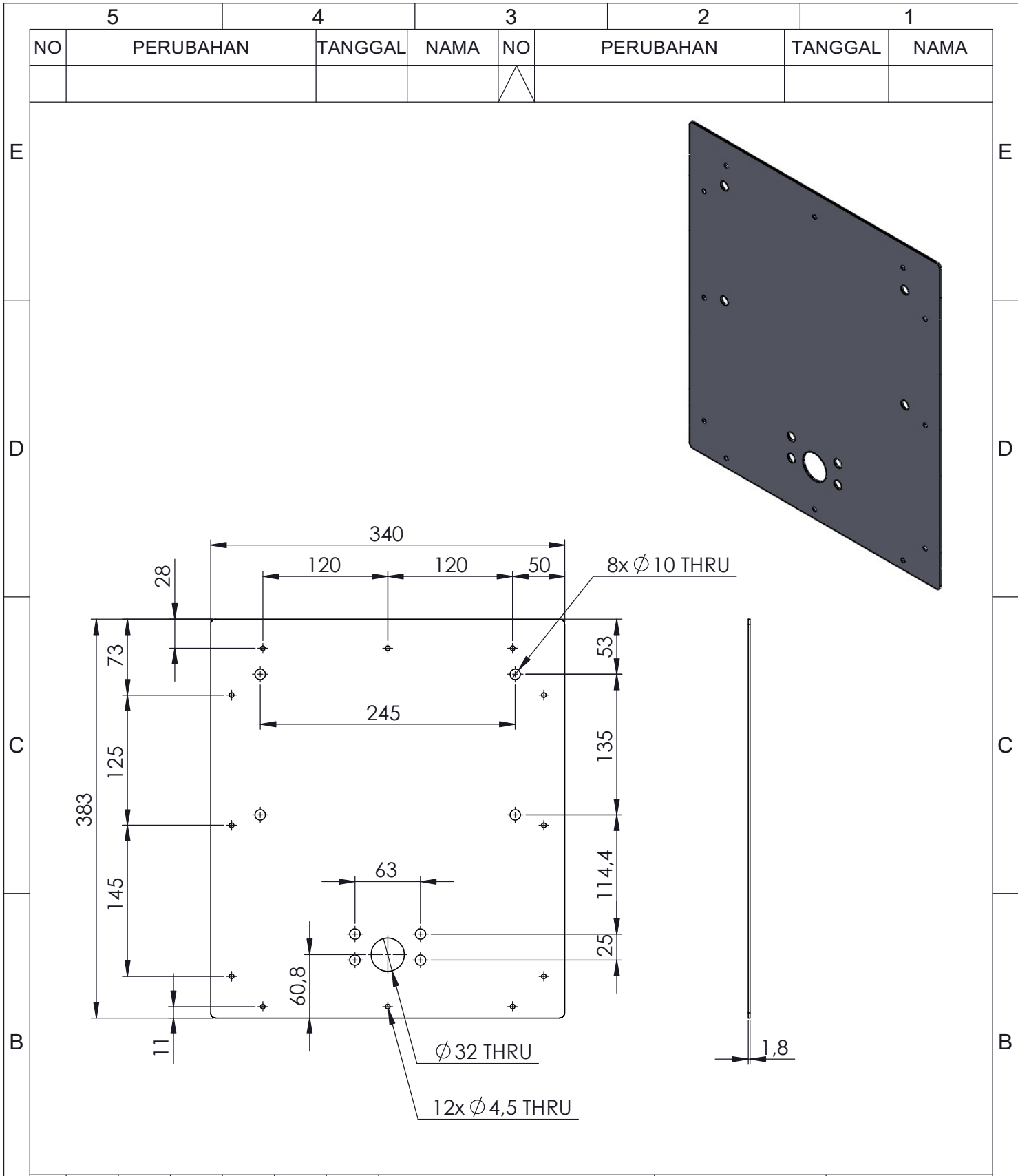

>	0	6	30	120	400	1000	UKURAN LANJUT
<	6	30	120	400	1000	2000	
TOL	±0.1	±0.2	±0.3	±0.5	±0.8	±1.2	

NO. ORDER		PROYEKSI	

NAMA :
BACK HOPPER

NO. ASSY. :

SKALA 1:5	DIGAMBAR	06-06-2022	IQBAL
	DIPERIKSA		
	DISAHKAN		

POLITEKNIK NEGERI CILACAP, JURUSAN TEKNIK MESIN
 JL. dr. SOETOMO, NO. 01, SIDAKAYA, CILACAP, 53212
 TELP : 0282 - 533329, E-mail : tmpnc@politeknikcilacap.ac.id

FORMAT A4	JTM19-02-03-01
---------------------	-----------------------

5		4		3		2		1	
NO	PERUBAHAN	TANGGAL	NAMA	NO	PERUBAHAN	TANGGAL	NAMA		
				△					

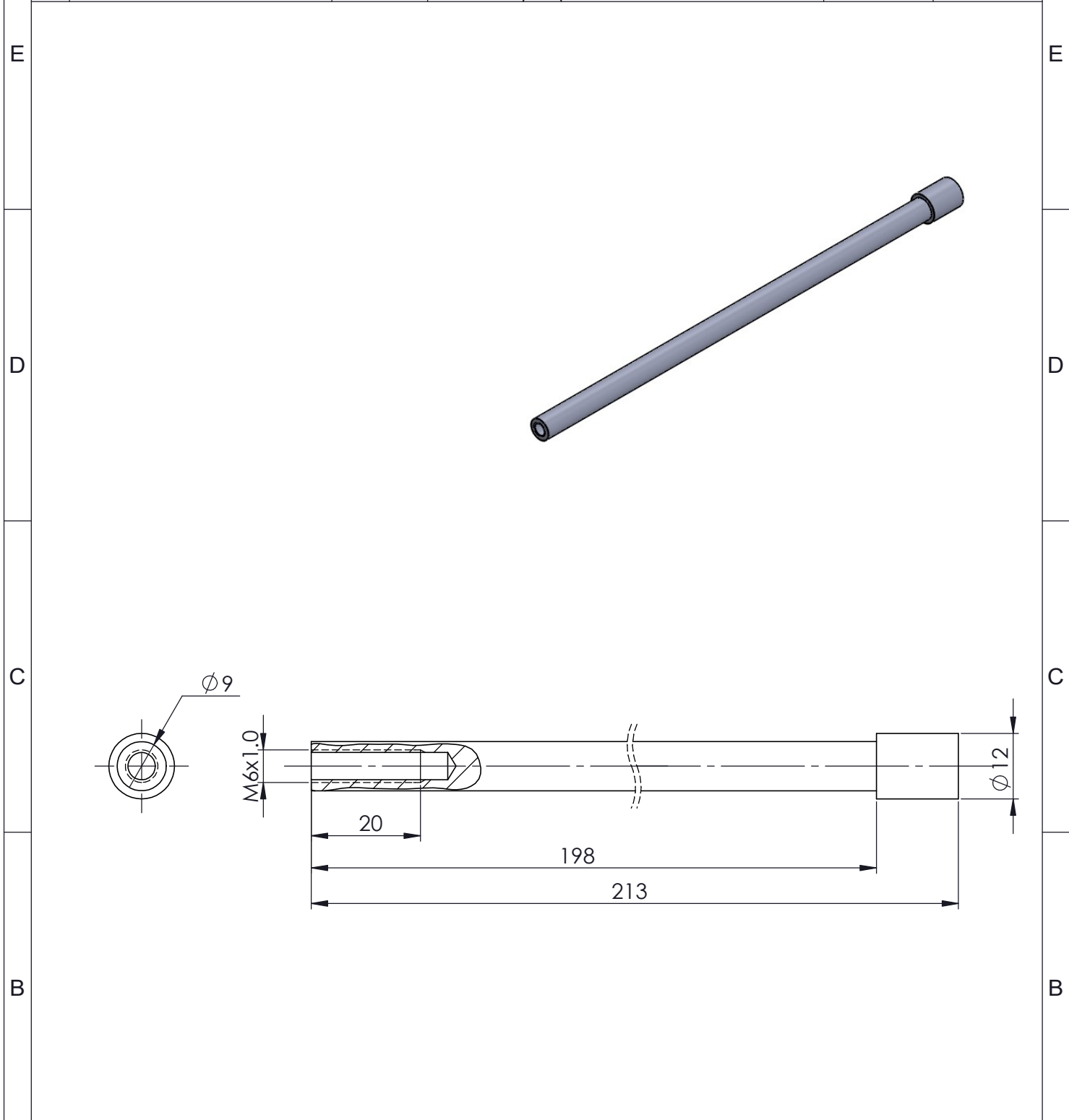

>	0	6	30	120	400	1000	UKURAN LANJUT	NO. ORDER	PROYEKSI		
<	6	30	120	400	1000	2000					
TOL	±0.1	±0.2	±0.3	±0.5	±0.8	±1.2					
NAMA :								SKALA	DIGAMBAR	06-06-2022	IQBAL
HOPPER FRAME								1:1	DIPERIKSA		
									DISAHKAN		
NO. ASSY. :								FORMAT	JTM19-02-03-02		
POLITEKNIK NEGERI CILACAP, JURUSAN TEKNIK MESIN JL. dr. SOETOMO, NO. 01, SIDAKAYA, CILACAP, 53212 TELP : 0282 - 533329, E-mail : tmpnc@politeknikcilacap.ac.id								A4			

PERUBAHAN DARI :

DIGANTI DENGAN :

5		4		3		2		1	
NO	PERUBAHAN	TANGGAL	NAMA	NO	PERUBAHAN	TANGGAL	NAMA		
				△					

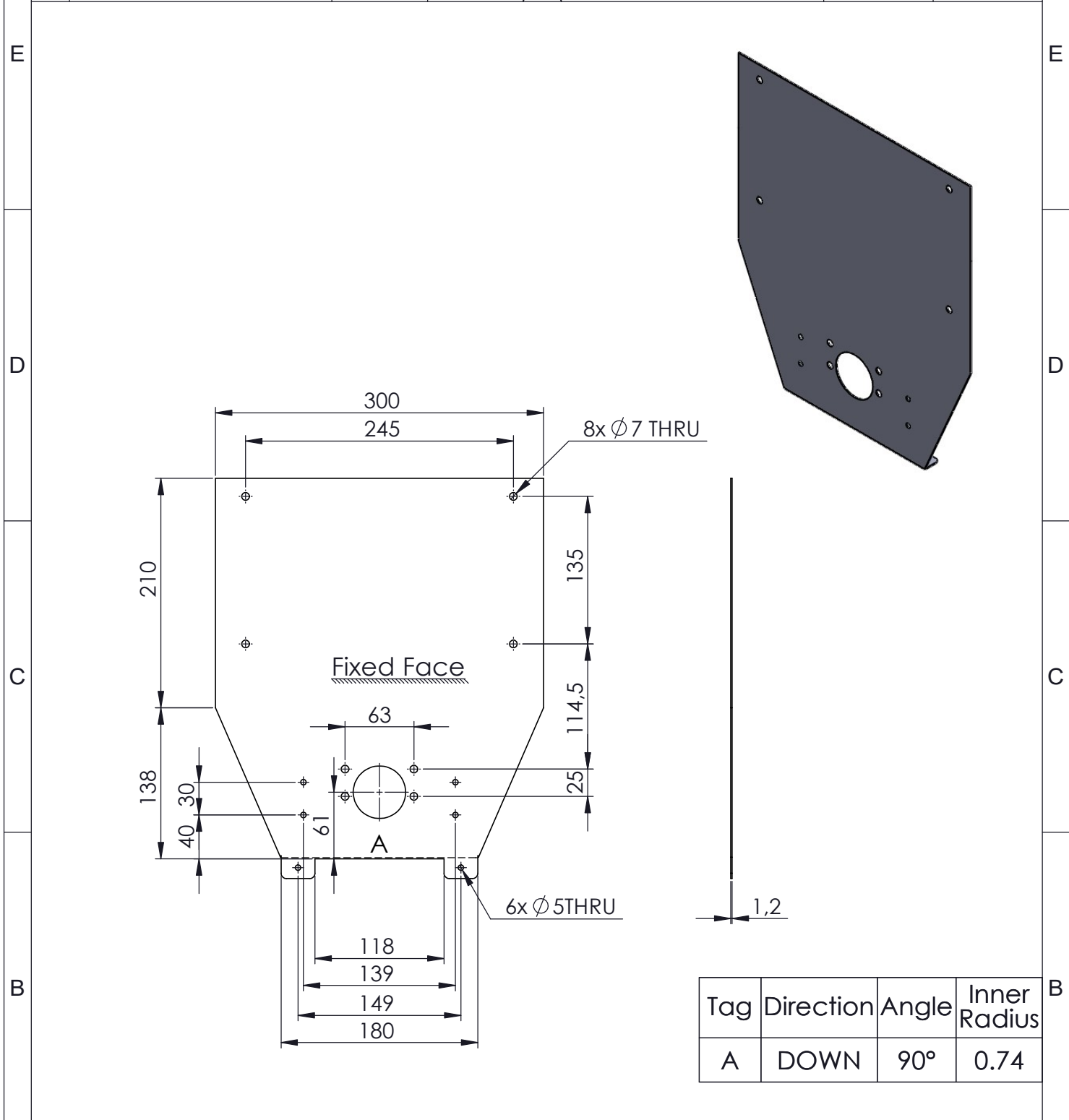

<table border="1"> <tr> <td>></td> <td>0</td> <td>6</td> <td>30</td> <td>120</td> <td>400</td> <td>1000</td> <td rowspan="3">UKURAN LANJUT</td> </tr> <tr> <td><</td> <td>6</td> <td>30</td> <td>120</td> <td>400</td> <td>1000</td> <td>2000</td> </tr> <tr> <td>TOL</td> <td>±0.1</td> <td>±0.2</td> <td>±0.3</td> <td>±0.5</td> <td>±0.8</td> <td>±1.2</td> </tr> </table>						>	0	6	30	120	400	1000	UKURAN LANJUT	<	6	30	120	400	1000	2000	TOL	±0.1	±0.2	±0.3	±0.5	±0.8	±1.2	NO. ORDER		PROYEKSI		
>	0	6	30	120	400	1000	UKURAN LANJUT																									
<	6	30	120	400	1000	2000																										
TOL	±0.1	±0.2	±0.3	±0.5	±0.8	±1.2																										
NAMA : <h2 style="text-align: center;">COVER FRONT HOPPER</h2> NO. ASSY. :								SKALA	DIGAMBAR	06-06-2022	IQBAL																					
								1:5	DIPERIKSA																							
									DISAHKAN																							
 POLITEKNIK NEGERI CILACAP, JURUSAN TEKNIK MESIN JL. dr. SOETOMO, NO. 01, SIDAKAYA, CILACAP, 53212 TELP : 0282 - 533329, E-mail : tmpnc@politeknikcilacap.ac.id						FORMAT		JTM19-02-04																								
5		4		3		2		1																								

PERUBAHAN DARI :

DIGANTI DENGAN :

5		4		3		2		1	
NO	PERUBAHAN	TANGGAL	NAMA	NO	PERUBAHAN	TANGGAL	NAMA		
				△					

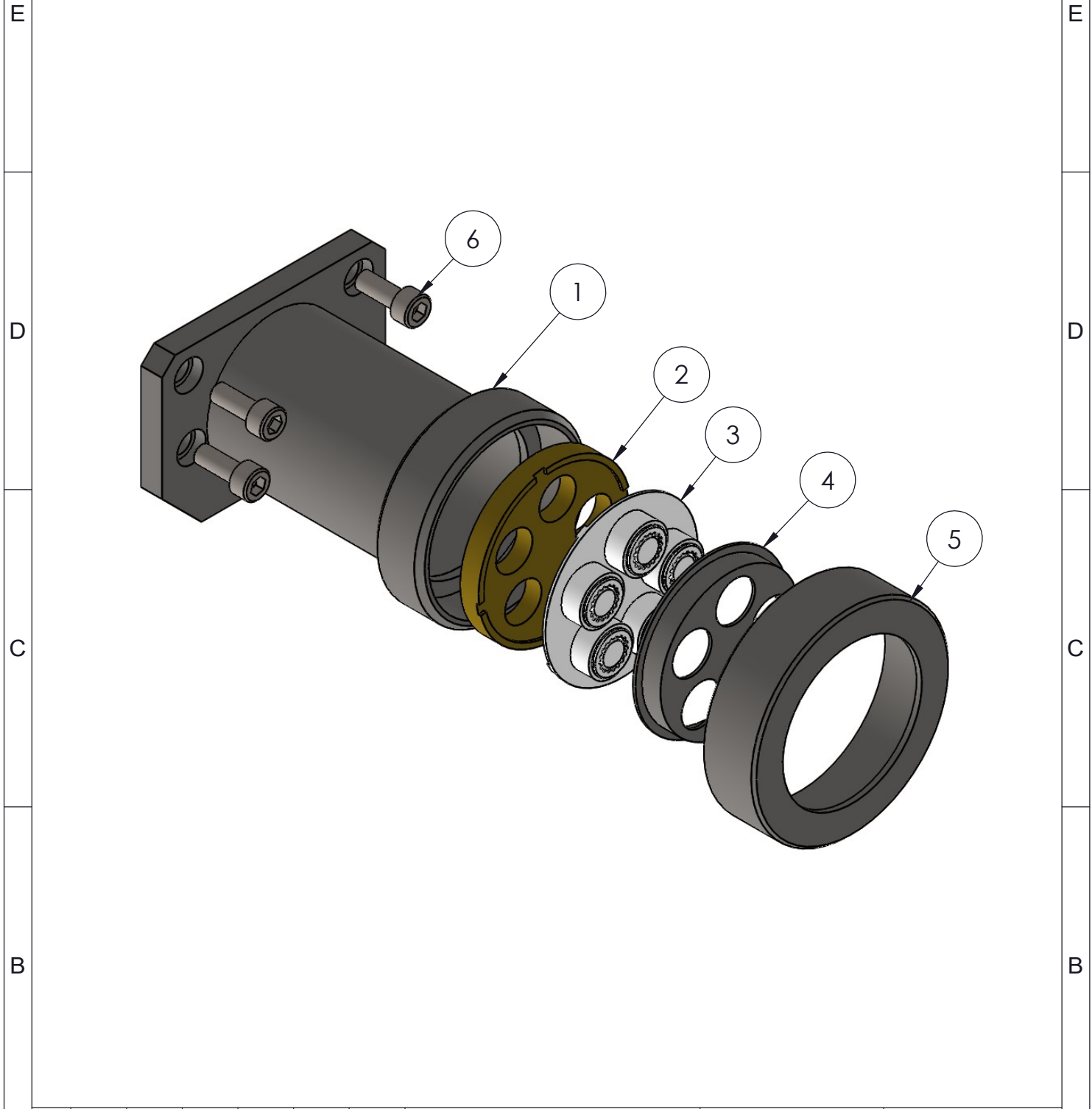

>	0	6	30	120	400	1000	UKURAN LANJUT
<	6	30	120	400	1000	2000	
TOL	±0.1	±0.2	±0.3	±0.5	±0.8	±1.2	

NO. ORDER		PROYEKSI	

NAMA :
DIE ASSY

NO. ASSY. :

SKALA 2:3	DIGAMBAR	06-06-2022	IQBAL
	DIPERIKSA		
	DISAHKAN		

POLITEKNIK NEGERI CILACAP, JURUSAN TEKNIK MESIN
 JL. dr. SOETOMO, NO. 01, SIDAKAYA, CILACAP, 53212
 TELP : 0282 - 533329, E-mail : tmpnc@politeknikcilacap.ac.id



FORMAT
A4

JTM19-03-00 (a)

5		4		3		2		1	
---	--	---	--	---	--	---	--	---	--

PERUBAHAN DARI :

DIGANTI DENGAN :

5		4			3		2		1		
NO	PERUBAHAN			TANGGAL	NAMA	NO	PERUBAHAN		TANGGAL	NAMA	
						△					
E											
D											
C											
B											
4	L HEX SHCS			6	STD	M6x1x20		-	-		
1	DIE LOCK			5	SS304	LIHAT DETAIL		-	JTM19-03-03		
1	DIE PLATE			4	STD	-		-	-		
1	INSERT DIE			3	STD	-		-	-		
1	BLOCK ADAPTER			2	BRONZE	LIHAT DETAIL		-	JTM19-03-02		
1	BARREL			1	SS304	LIHAT DETAIL		-	JTM19-03-01		
JML	NAMA BAGIAN			POS	BAHAN	UKURAN JADI		UKURAN KASAR		NO. ID	
>	0	6	30	120	400	1000	UKURAN LANJUT		NO. ORDER PROYEKSI 		
<	6	30	120	400	1000	2000					
TOL	±0.1	±0.2	±0.3	±0.5	±0.8	±1.2					
NAMA :								SKALA	DIGAMBAR	06-06-2022	IQBAL
DIE ASSY								1:1	DIPERIKSA		
									DISAHKAN		
NO. ASSY. :								FORMAT	JTM19-03-00 (b)		
 POLITEKNIK NEGERI CILACAP, JURUSAN TEKNIK MESIN JL. dr. SOETOMO, NO. 01, SIDAKAYA, CILACAP, 53212 TELP : 0282 - 533329, E-mail : tmpnc@politeknikcilacap.ac.id								A4			
5		4			3		2		1		

5		4		3		2		1	
NO	PERUBAHAN	TANGGAL	NAMA	NO	PERUBAHAN	TANGGAL	NAMA		
				△					

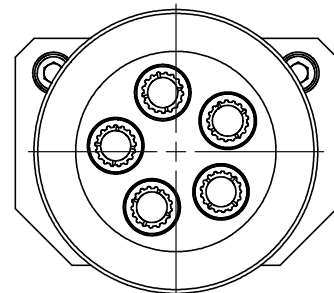
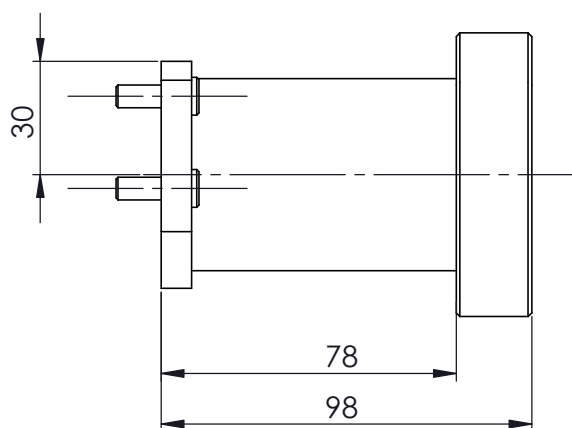
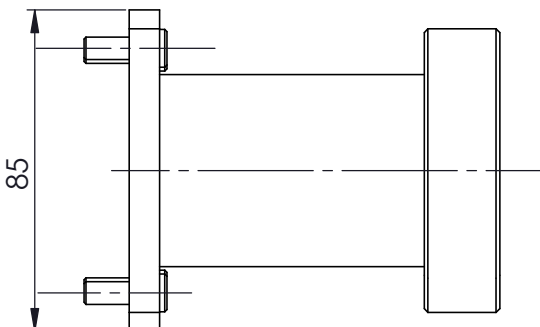
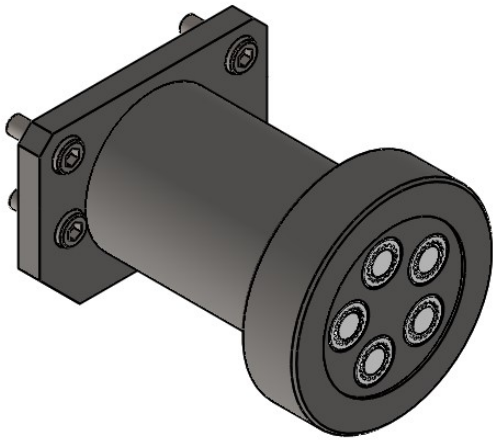

>	0	6	30	120	400	1000	UKURAN LANJUT
<	6	30	120	400	1000	2000	
TOL	±0.1	±0.2	±0.3	±0.5	±0.8	±1.2	

NO. ORDER		PROYEKSI	

NAMA :
DIE ASSY

NO. ASSY. :

SKALA 1:2	DIGAMBAR	06-06-2022	IQBAL
	DIPERIKSA		
	DISAHKAN		

POLITEKNIK NEGERI CILACAP, JURUSAN TEKNIK MESIN
 JL. dr. SOETOMO, NO. 01, SIDAKAYA, CILACAP, 53212
 TELP : 0282 - 533329, E-mail : tmpnc@politeknikcilacap.ac.id

FORMAT A4	JTM19-03-00 (c)
---------------------	------------------------

5		4		3		2		1	
---	--	---	--	---	--	---	--	---	--

PERUBAHAN DARI :

DIGANTI DENGAN :

5		4		3		2		1	
NO	PERUBAHAN	TANGGAL	NAMA	NO	PERUBAHAN	TANGGAL	NAMA		
				△					

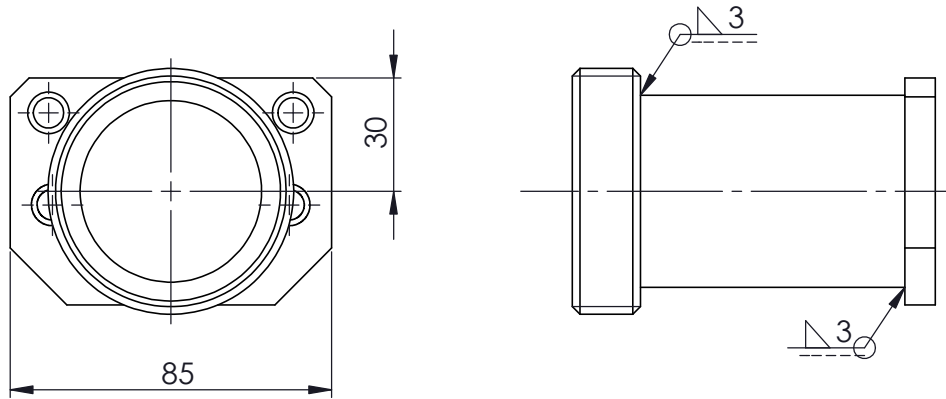
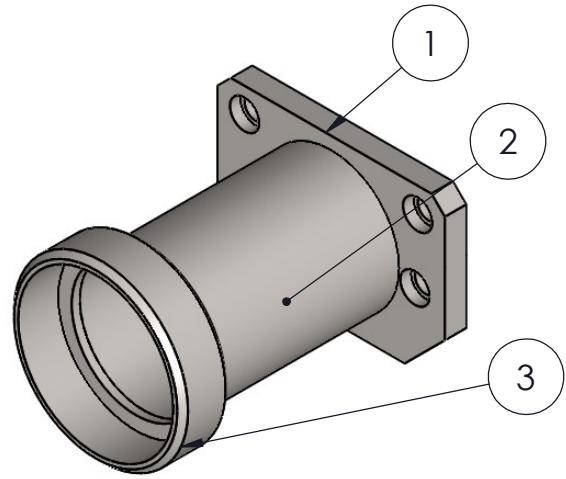

1	HOUSING DIE	3	SS304	LIHAT DETAIL	-	JTM19-03-01-03
1	CHASING	2	SS304	LIHAT DETAIL	-	JTM19-03-01-02
1	BARREL BRACKET	1	SS304	LIHAT DETAIL	-	JTM19-03-01-01

JML	NAMA BAGIAN					POS	BAHAN	UKURAN JADI	UKURAN KASAR	NO. ID	F
>	0	6	30	120	400	1000	UKURAN LANJUT		NO. ORDER	PROYEKSI	
<	6	30	120	400	1000	2000					
TOL	±0.1	±0.2	±0.3	±0.5	±0.8	±1.2					

NAMA :				SKALA	DIGAMBAR	06-06-2022	IQBAL
BARREL				1:2	DIPERIKSA		
					DISAHKAN		
NO. ASSY. :							

POLITEKNIK NEGERI CILACAP, JURUSAN TEKNIK MESIN JL. dr. SOETOMO, NO. 01, SIDAKAYA, CILACAP, 53212 TELP : 0282 - 533329, E-mail : tmpnc@politeknikcilacap.ac.id				FORMAT	JTM19-03-01		
				A4			

5		4		3		2		1	
---	--	---	--	---	--	---	--	---	--

PERUBAHAN DARI :

DIGANTI DENGAN :

5		4		3		2		1	
NO	PERUBAHAN	TANGGAL	NAMA	NO	PERUBAHAN	TANGGAL	NAMA		
				△					

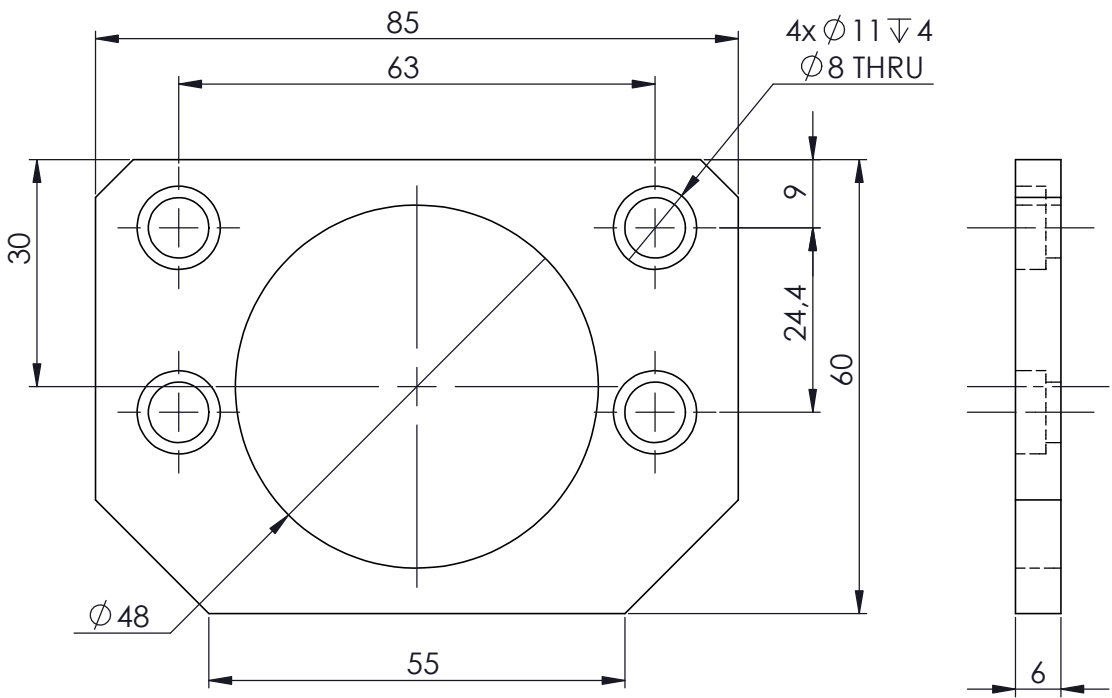
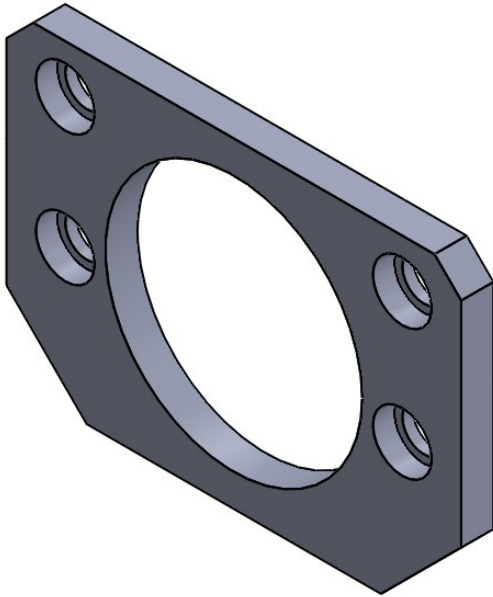

>	0	6	30	120	400	1000	UKURAN LANJUT
<	6	30	120	400	1000	2000	
TOL	±0.1	±0.2	±0.3	±0.5	±0.8	±1.2	

NO. ORDER		PROYEKSI	

NAMA :
BARREL BRACKET

NO. ASSY. :

SKALA 1:1	DIGAMBAR	06-06-2022	IQBAL
	DIPERIKSA		
	DISAHKAN		

POLITEKNIK NEGERI CILACAP, JURUSAN TEKNIK MESIN
 JL. dr. SOETOMO, NO. 01, SIDAKAYA, CILACAP, 53212
 TELP : 0282 - 533329, E-mail : tmpnc@politeknikcilacap.ac.id

FORMAT A4	JTM19-03-01-01
---------------------	-----------------------

5		4		3		2		1	
NO	PERUBAHAN	TANGGAL	NAMA	NO	PERUBAHAN	TANGGAL	NAMA		
				△					

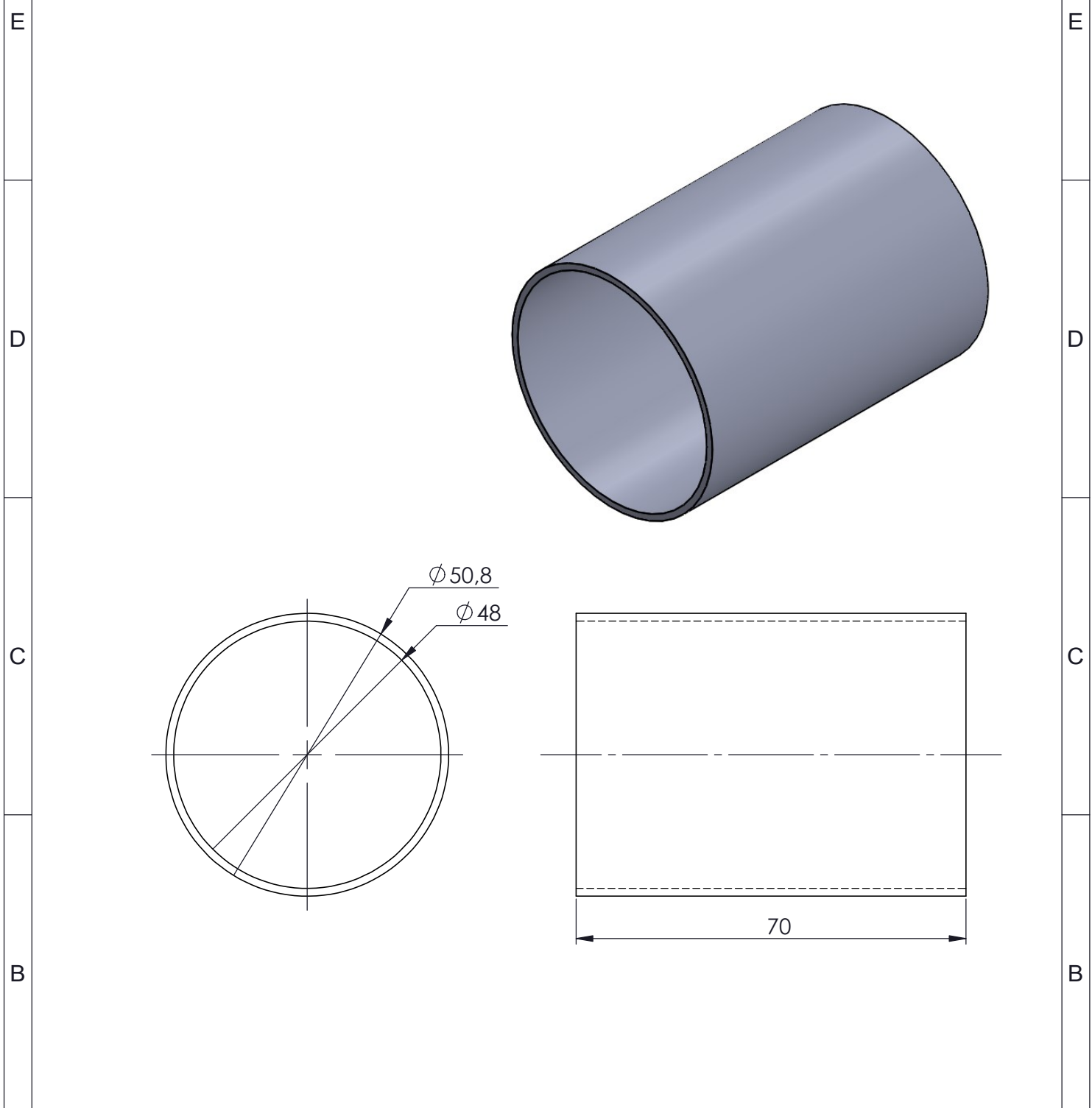

>	0	6	30	120	400	1000	UKURAN LANJUT
<	6	30	120	400	1000	2000	
TOL	± 0.1	± 0.2	± 0.3	± 0.5	± 0.8	± 1.2	

NO. ORDER		PROYEKSI	

NAMA :
CHASING

NO. ASSY. :

SKALA 1:1	DIGAMBAR	06-06-2022	IQBAL
	DIPERIKSA		
	DISAHKAN		

POLITEKNIK NEGERI CILACAP, JURUSAN TEKNIK MESIN
 JL. dr. SOETOMO, NO. 01, SIDAKAYA, CILACAP, 53212
 TELP : 0282 - 533329, E-mail : tmpnc@politeknikcilacap.ac.id

FORMAT A4	JTM19-03-01-02
---------------------	-----------------------

5		4		3		2		1	
---	--	---	--	---	--	---	--	---	--

PERUBAHAN DARI :

DIGANTI DENGAN :

5		4		3		2		1	
NO	PERUBAHAN	TANGGAL	NAMA	NO	PERUBAHAN	TANGGAL	NAMA		
				△					

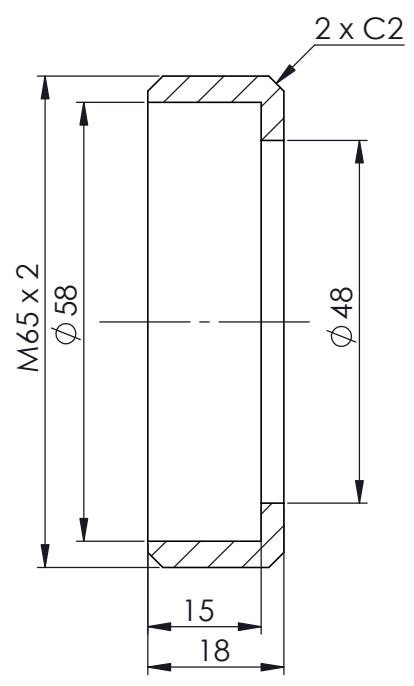
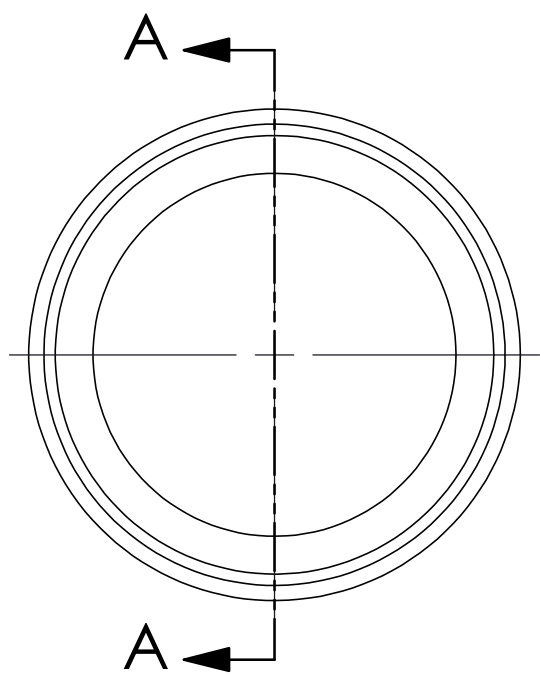
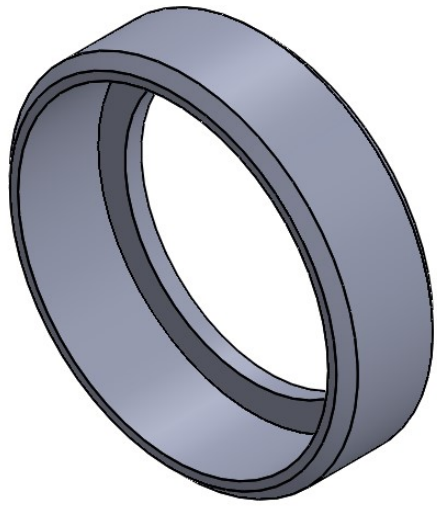

SECTION A-A

>	0	6	30	120	400	1000	UKURAN LANJUT
<	6	30	120	400	1000	2000	
TOL	±0.1	±0.2	±0.3	±0.5	±0.8	±1.2	

NO. ORDER		PROYEKSI	

NAMA :
HOUSING DIE

NO. ASSY. :

SKALA 1:1	DIGAMBAR	06-06-2022	IQBAL
	DIPERIKSA		
	DISAHKAN		

POLITEKNIK NEGERI CILACAP, JURUSAN TEKNIK MESIN
 JL. dr. SOETOMO, NO. 01, SIDAKAYA, CILACAP, 53212
 TELP : 0282 - 533329, E-mail : tmpnc@politeknikcilacap.ac.id

FORMAT
A4

JTM19-03-01-03

5		4		3		2		1	
NO	PERUBAHAN	TANGGAL	NAMA	NO	PERUBAHAN	TANGGAL	NAMA		
				△					

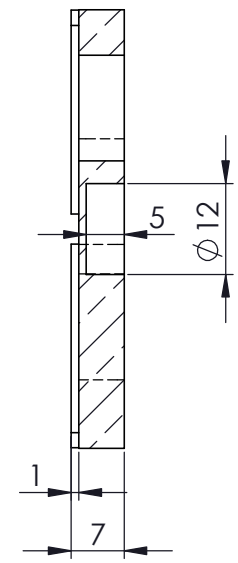
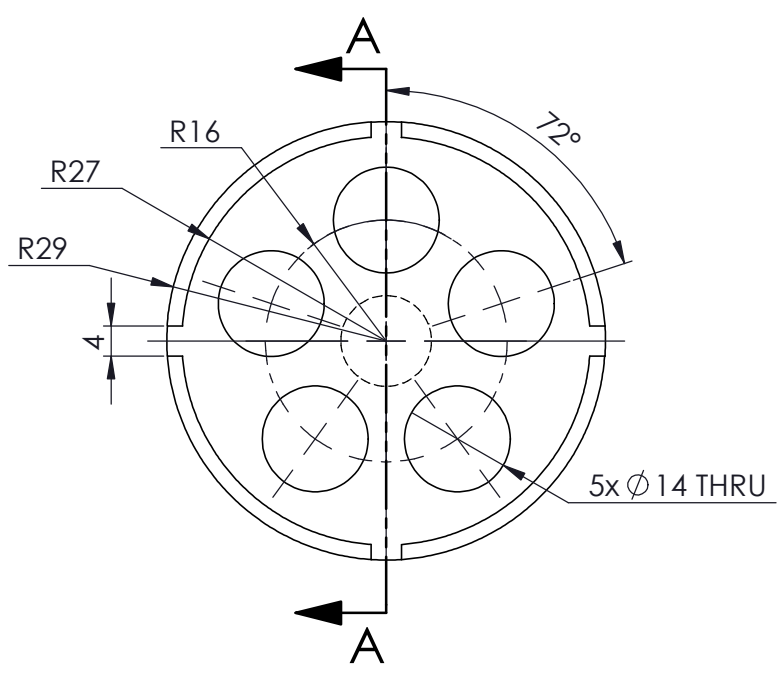
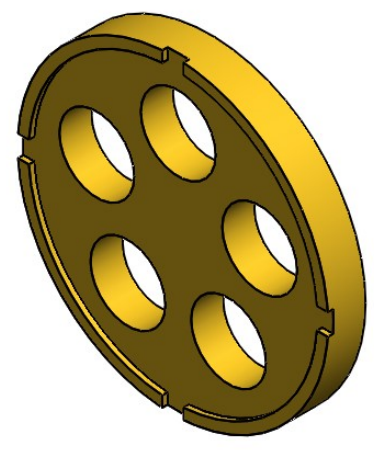

SECTION A-A

>	0	6	30	120	400	1000	UKURAN LANJUT
<	6	30	120	400	1000	2000	
TOL	±0.1	±0.2	±0.3	±0.5	±0.8	±1.2	

NO. ORDER		PROYEKSI	

NAMA :
BLOCK ADAPTER

NO. ASSY. :

SKALA 1:1	DIGAMBAR	0606-2022	IQBAL
	DIPERIKSA		
	DISAHKAN		

POLITEKNIK NEGERI CILACAP, JURUSAN TEKNIK MESIN
 JL. dr. SOETOMO, NO. 01, SIDAKAYA, CILACAP, 53212
 TELP : 0282 - 533329, E-mail : tmpnc@politeknikcilacap.ac.id

FORMAT A4	JTM19-03-02
---------------------	--------------------

5		4		3		2		1	
NO	PERUBAHAN	TANGGAL	NAMA	NO	PERUBAHAN	TANGGAL	NAMA		
				△					

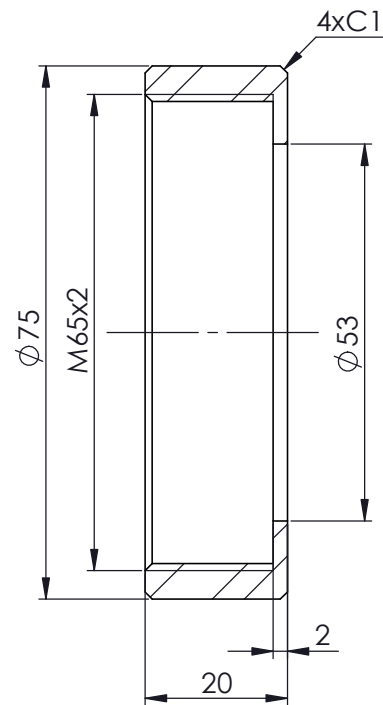
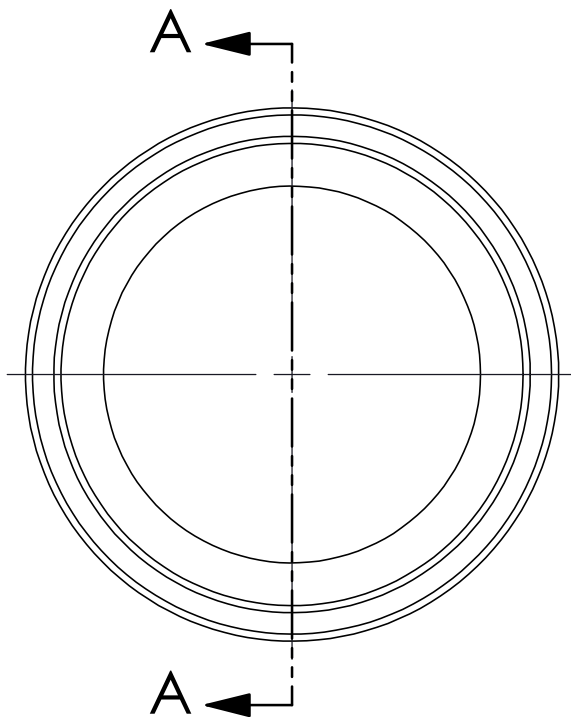

SECTION A-A

>	0	6	30	120	400	1000	UKURAN LANJUT
<	6	30	120	400	1000	2000	
TOL	±0.1	±0.2	±0.3	±0.5	±0.8	±1.2	

NO. ORDER		PROYEKSI	

NAMA :
DIE LOCK

NO. ASSY. :

SKALA 1:1	DIGAMBAR	06-06-2022	IQBAL
	DIPERIKSA		
	DISAHKAN		

POLITEKNIK NEGERI CILACAP, JURUSAN TEKNIK MESIN
 JL. dr. SOETOMO, NO. 01, SIDAKAYA, CILACAP, 53212
 TELP : 0282 - 533329, E-mail :tmpnc@politeknikcilacap.ac.id

FORMAT A4	JTM19-03-03
---------------------	--------------------

PERUBAHAN DARI :

DIGANTI DENGAN :

5		4		3		2		1	
NO	PERUBAHAN	TANGGAL	NAMA	NO	PERUBAHAN	TANGGAL	NAMA		
				△					

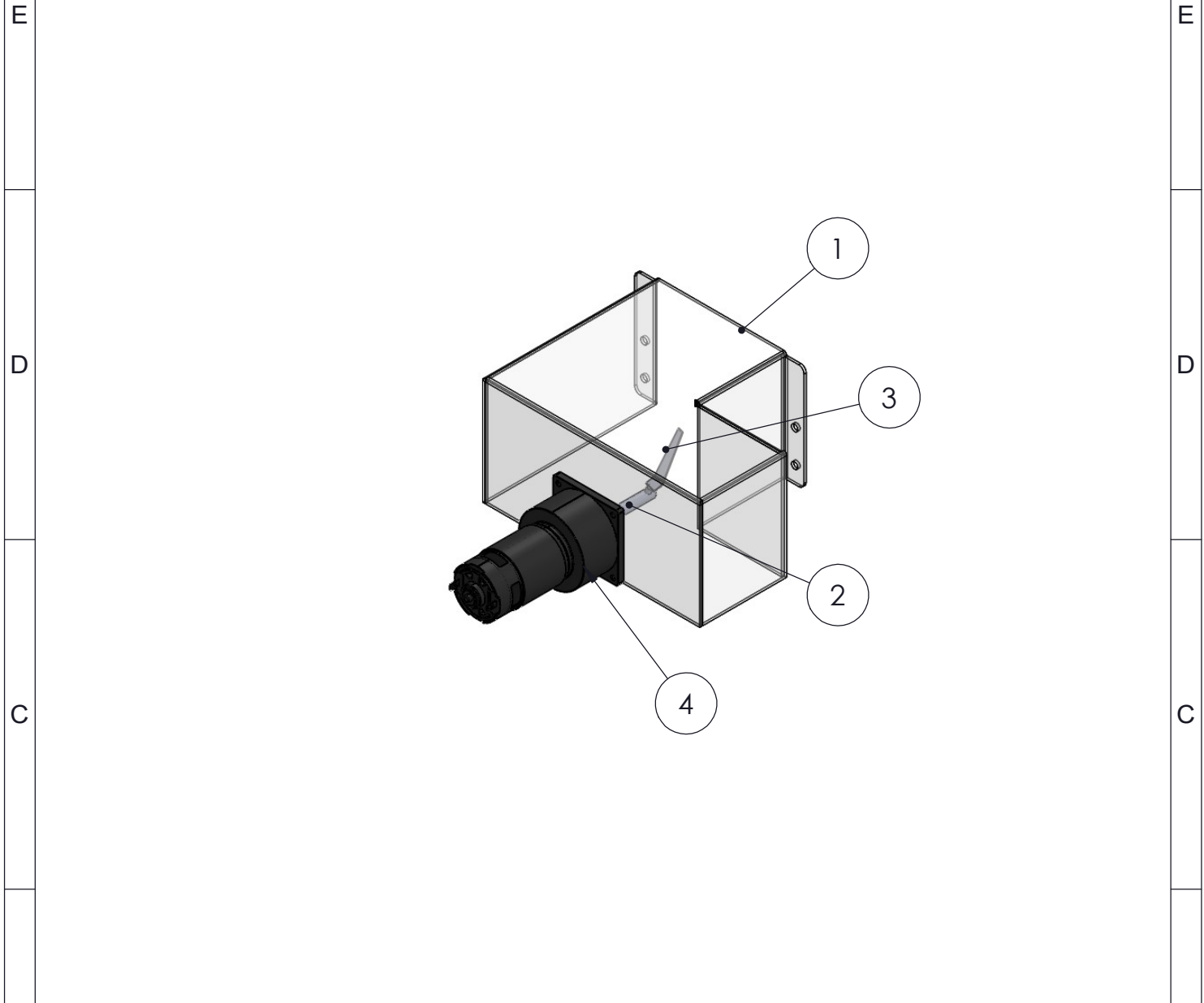

1	MOTOR DC	4	STD	12VDC 6W	-	-	
1	BLADE	3	SS304	LIHAT DETAIL	-	JTM19-04-03	
1	SHAFT CUTTING	2	SS304	LIHAT DETAIL	-	JTM19-04-02	
1	BRACKET	1	ACRYLIC	LIHAT DETAIL	-	JTM19-04-01	

JML	NAMA BAGIAN					POS	BAHAN	UKURAN JADI	UKURAN KASAR	NO. ID	F
>	0	6	30	120	400	1000	UKURAN LANJUT		NO. ORDER	PROYEKSI	
<	6	30	120	400	1000	2000					
TOL	±0.1	±0.2	±0.3	±0.5	±0.8	±1.2					

NAMA :								SKALA	DIGAMBAR	06-06-2022	IQBAL
CUTTING ASSY								1:4	DIPERIKSA		
									DISAHKAN		
NO. ASSY. :								FORMAT	JTM19-04-00 (a)		
								A4			

5		4		3		2		1	
---	--	---	--	---	--	---	--	---	--

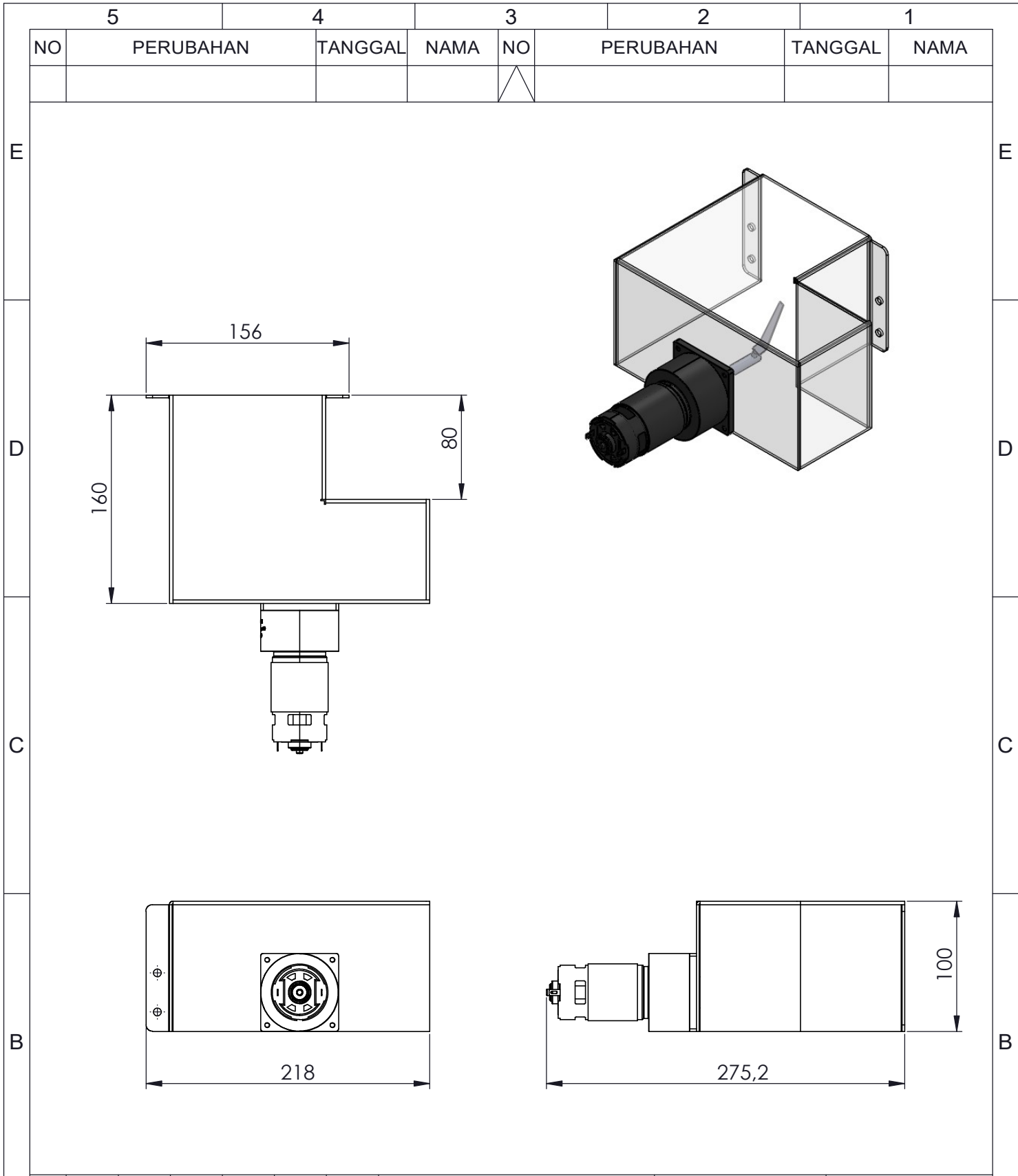

	>	0	6	30	120	400	1000	UKURAN LANJUT	NO. ORDER	PROYEKSI		
	<	6	30	120	400	1000	2000					
TOL	±0.1	±0.2	±0.3	±0.5	±0.8	±1.2						
NAMA : CUTTING ASSY									SKALA		DIGAMBAR	06-06-2022
NO. ASSY. :									1:4	DIPERIKSA		
POLITEKNIK NEGERI CILACAP, JURUSAN TEKNIK MESIN JL. dr. SOETOMO, NO. 01, SIDAKAYA, CILACAP, 53212 TELP : 0282 - 533329, E-mail : tmpnc@politeknikcilacap.ac.id									A4	JTM19-04-00 (b)		
	5	4	3	2	1							

PERUBAHAN DARI :

DIGANTI DENGAN :

5		4		3		2		1	
NO	PERUBAHAN	TANGGAL	NAMA	NO	PERUBAHAN	TANGGAL	NAMA		
				△					

E

E

D

D

C

C

B

B

A

A

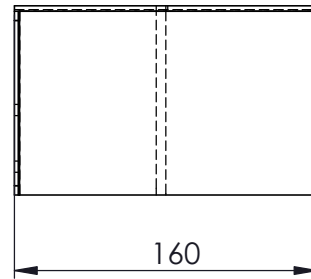
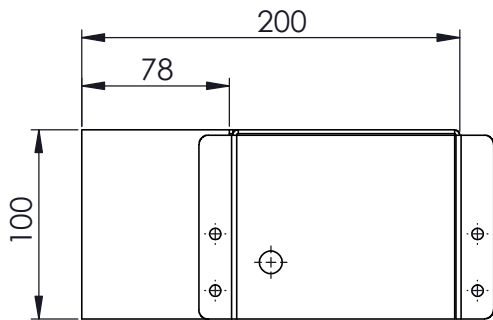
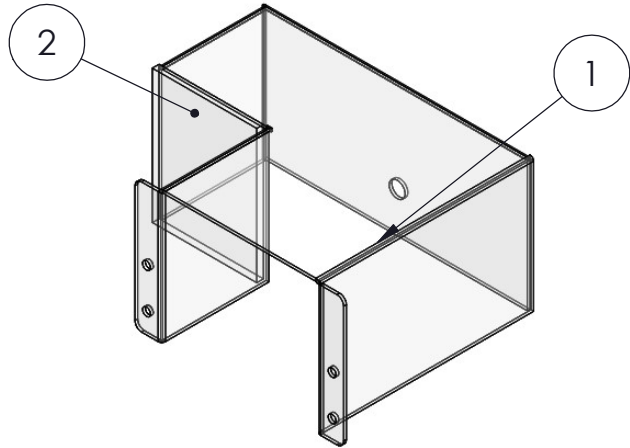

1	BRACKET SIDE					2	ACRYLIC	LIHAT DETAIL	-	JTM19-04-01-02		
1	BRACKET 01					1	ACRYLIC	LIHAT DETAIL	-	JTM19-04-01-01		
JML	NAMA BAGIAN					POS	BAHAN	UKURAN JADI	UKURAN KASAR	NO. ID	F	
>	0	6	30	120	400	1000	UKURAN LANJUT		NO. ORDER	PROYEKSI		
<	6	30	120	400	1000	2000						
TOL	±0.1	±0.2	±0.3	±0.5	±0.8	±1.2						
NAMA :									SKALA	DIGAMBAR	06-06-2022	IQBAL
BRACKET									1:4	DIPERIKSA		
										DISAHKAN		
NO. ASSY. :									FORMAT	JTM19-04-01-00		
POLITEKNIK NEGERI CILACAP, JURUSAN TEKNIK MESIN JL. dr. SOETOMO, NO. 01, SIDAKAYA, CILACAP, 53212 TELP : 0282 - 533329, E-mail : tmpnc@politeknikcilacap.ac.id									A4			

5

4

3

2

1

PERUBAHAN DARI :

DIGANTI DENGAN :

5		4		3		2		1	
NO	PERUBAHAN	TANGGAL	NAMA	NO	PERUBAHAN	TANGGAL	NAMA		
				△					

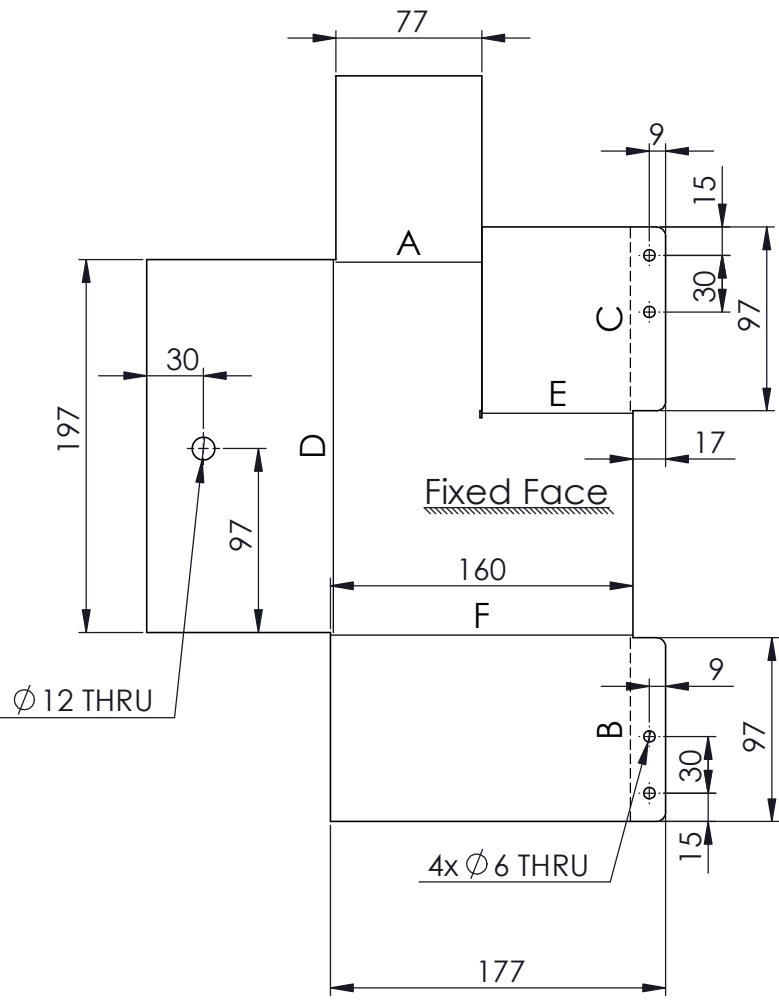
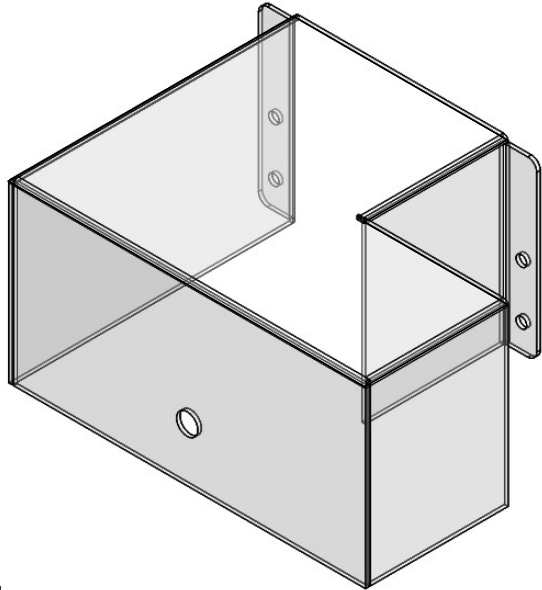

Tag	Direction	Angle	Inner Radius
A	UP	90°	0.74
B	DOWN	90°	0.74
C	DOWN	90°	0.74
D	UP	90°	0.74
E	UP	90°	0.74
F	UP	90°	0.74

>	0	6	30	120	400	1000	UKURAN LANJUT
<	6	30	120	400	1000	2000	
TOL	±0.1	±0.2	±0.3	±0.5	±0.8	±1.2	

NO. ORDER		PROYEKSI	

NAMA :
BRACKET 01

NO. ASSY. :

SKALA 1:4	DIGAMBAR	06-06-2022	IQBAL
	DIPERIKSA		
	DISAHKAN		

POLITEKNIK NEGERI CILACAP, JURUSAN TEKNIK MESIN
 JL. dr. SOETOMO, NO. 01, SIDAKAYA, CILACAP, 53212
 TELP : 0282 - 533329, E-mail : tmpnc@politeknikcilacap.ac.id

FORMAT A4	JTM19-04-01-01
---------------------	-----------------------

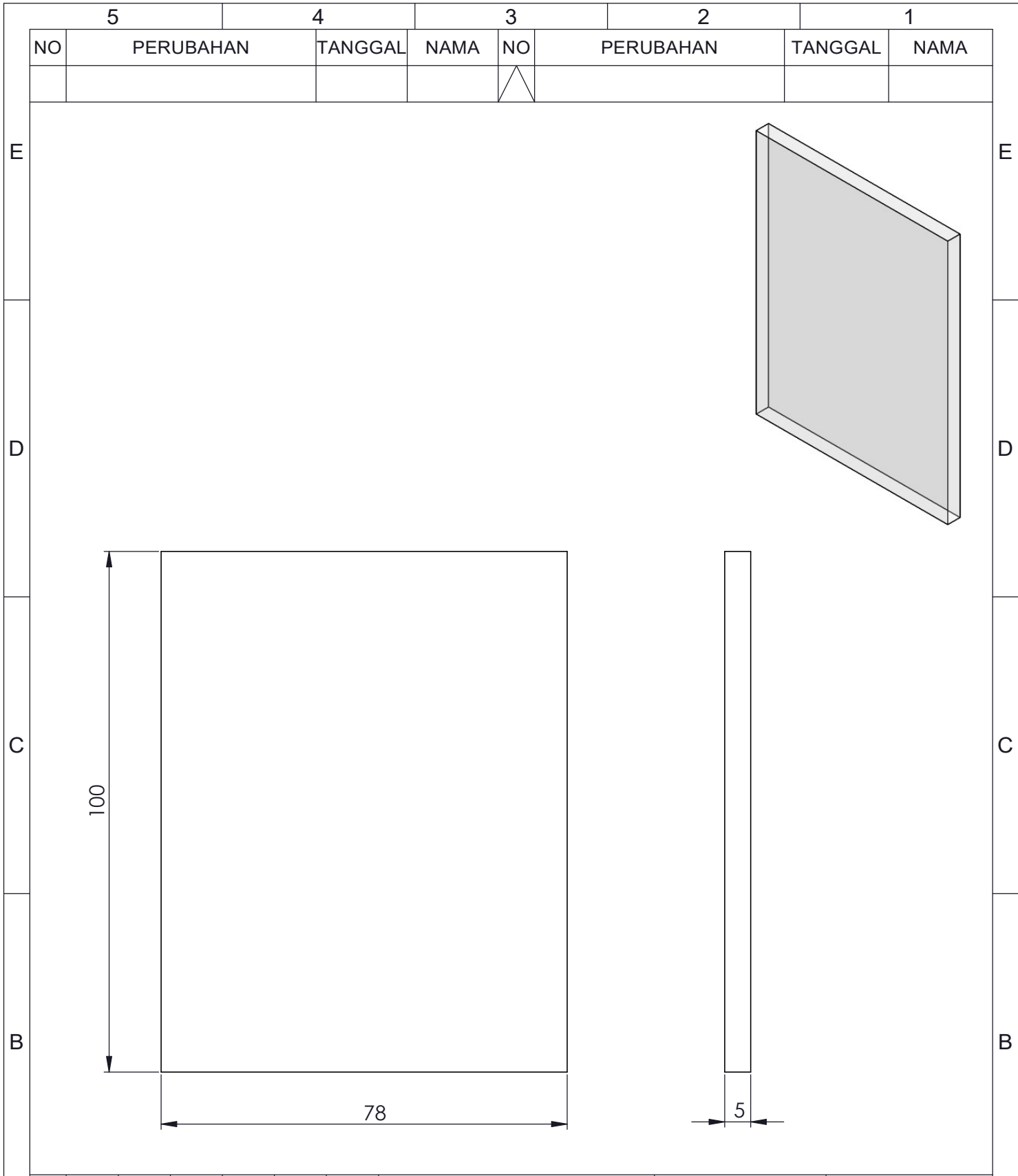

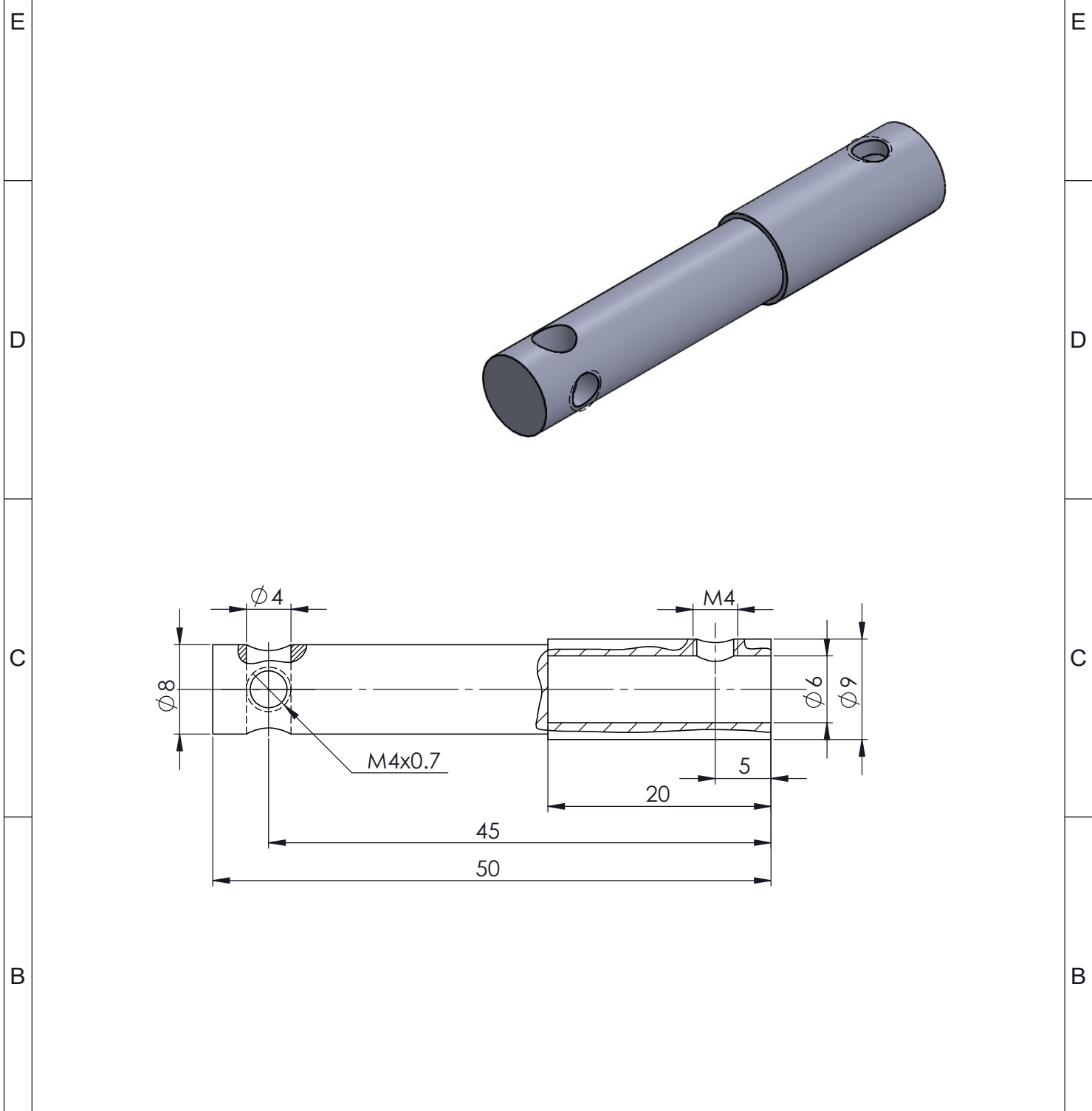

>	0	6	30	120	400	1000	UKURAN LANJUT	NO. ORDER	PROYEKSI										
<	6	30	120	400	1000	2000													
TOL	±0.1	±0.2	±0.3	±0.5	±0.8	±1.2			<table border="1" style="width:100%; border-collapse: collapse;"> <tr> <td style="width: 5%;">SKALA</td> <td style="width: 10%;">DIGAMBAR</td> <td style="width: 10%;">06-06-2022</td> <td style="width: 10%;">IQBAL</td> </tr> <tr> <td>1:1</td> <td>DIPERIKSA</td> <td> </td> <td> </td> </tr> <tr> <td> </td> <td>DISAHKAN</td> <td> </td> <td> </td> </tr> </table>	SKALA	DIGAMBAR	06-06-2022	IQBAL	1:1	DIPERIKSA				DISAHKAN
SKALA	DIGAMBAR	06-06-2022	IQBAL																
1:1	DIPERIKSA																		
	DISAHKAN																		
NAMA : BRACKET SIDE								FORMAT A4											
NO. ASSY. :								JTM19-04-01-02											

5		4		3		2		1	
NO	PERUBAHAN	TANGGAL	NAMA	NO	PERUBAHAN	TANGGAL	NAMA		
				△					

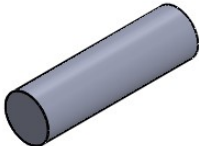
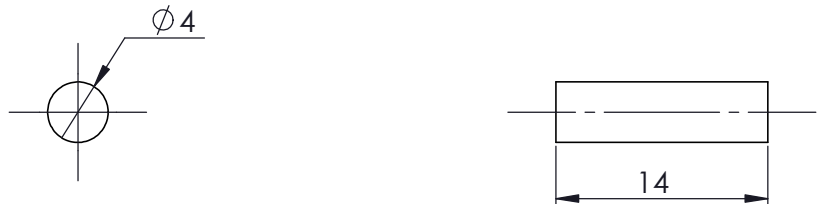

>	0	6	30	120	400	1000	UKURAN LANJUT	NO. ORDER	PROYEKSI		
<	6	30	120	400	1000	2000					
TOL	±0.1	±0.2	±0.3	±0.5	±0.8	±1.2					
NAMA :								SKALA	DIGAMBAR	06-06-2022	IQBAL
SHAFT CUTTER								2:1	DIPERIKSA		
									DISAHKAN		
NO. ASSY. :								FORMAT	JTM19-04-02		
POLITEKNIK NEGERI CILACAP, JURUSAN TEKNIK MESIN JL. dr. SOETOMO, NO. 01, SIDAKAYA, CILACAP, 53212 TELP : 0282 - 533329, E-mail : tmpnc@politeknikcilacap.ac.id								A4			

5		4			3		2		1		
NO	PERUBAHAN			TANGGAL	NAMA	NO	PERUBAHAN		TANGGAL	NAMA	
						△					
1	BLADE PROFILE			2	SS304	LIHAT DETAIL		-	JTM19-04-03-02		
1	BLADE SHAFT			1	SS304	LIHAT DETAIL		-	JTM19-04-03-01		
JML	NAMA BAGIAN			POS	BAHAN	UKURAN JADI		UKURAN KASAR	NO. ID	F	
>	0	6	30	120	400	1000	UKURAN LANJUT		NO. ORDER	PROYEKSI	
<	6	30	120	400	1000	2000					
TOL	±0.1	±0.2	±0.3	±0.5	±0.8	±1.2					
NAMA :							SKALA	DIGAMBAR	06-06-2022	IQBAL	
BLADE							1:1	DIPERIKSA			
NO. ASSY. :								DISAHKAN			
POLITEKNIK NEGERI CILACAP, JURUSAN TEKNIK MESIN JL. dr. SOETOMO, NO. 01, SIDAKAYA, CILACAP, 53212 TELP : 0282 - 533329, E-mail : tmpnc@politeknikcilacap.ac.id							FORMAT	JTM19-04-03-00			
							A4				

5		4			3		2			1																							
NO	PERUBAHAN	TANGGAL	NAMA	NO	PERUBAHAN	TANGGAL	NAMA	TANGGAL	NAMA	TANGGAL	NAMA																						
				△																													
 																																	
<table border="1" style="width:100%; border-collapse: collapse;"> <tr> <td>></td><td>0</td><td>6</td><td>30</td><td>120</td><td>400</td><td>1000</td><td rowspan="3">UKURAN LANJUT</td> </tr> <tr> <td><</td><td>6</td><td>30</td><td>120</td><td>400</td><td>1000</td><td>2000</td> </tr> <tr> <td>TOL</td><td>±0.1</td><td>±0.2</td><td>±0.3</td><td>±0.5</td><td>±0.8</td><td>±1.2</td> </tr> </table>							>	0	6	30	120	400	1000	UKURAN LANJUT	<	6	30	120	400	1000	2000	TOL	±0.1	±0.2	±0.3	±0.5	±0.8	±1.2	NO. ORDER		PROYEKSI		
>	0	6	30	120	400	1000	UKURAN LANJUT																										
<	6	30	120	400	1000	2000																											
TOL	±0.1	±0.2	±0.3	±0.5	±0.8	±1.2																											
NAMA : <h2 style="text-align: center;">BLADE SHAFT</h2> NO. ASSY. :							SKALA 2:1	DIGAMBAR	06-06-2022	IQBAL																							
								DIPERIKSA																									
								DISAHKAN																									
 POLITEKNIK NEGERI CILACAP, JURUSAN TEKNIK MESIN JL. dr. SOETOMO, NO. 01, SIDAKAYA, CILACAP, 53212 TELP : 0282 - 533329, E-mail : tmpnc@politeknikcilacap.ac.id							FORMAT	JTM19-04-03-01																									
5		4			3		2			1																							

PERUBAHAN DARI :

DIGANTI DENGAN :

5		4		3		2		1	
NO	PERUBAHAN	TANGGAL	NAMA	NO	PERUBAHAN	TANGGAL	NAMA		
				△					

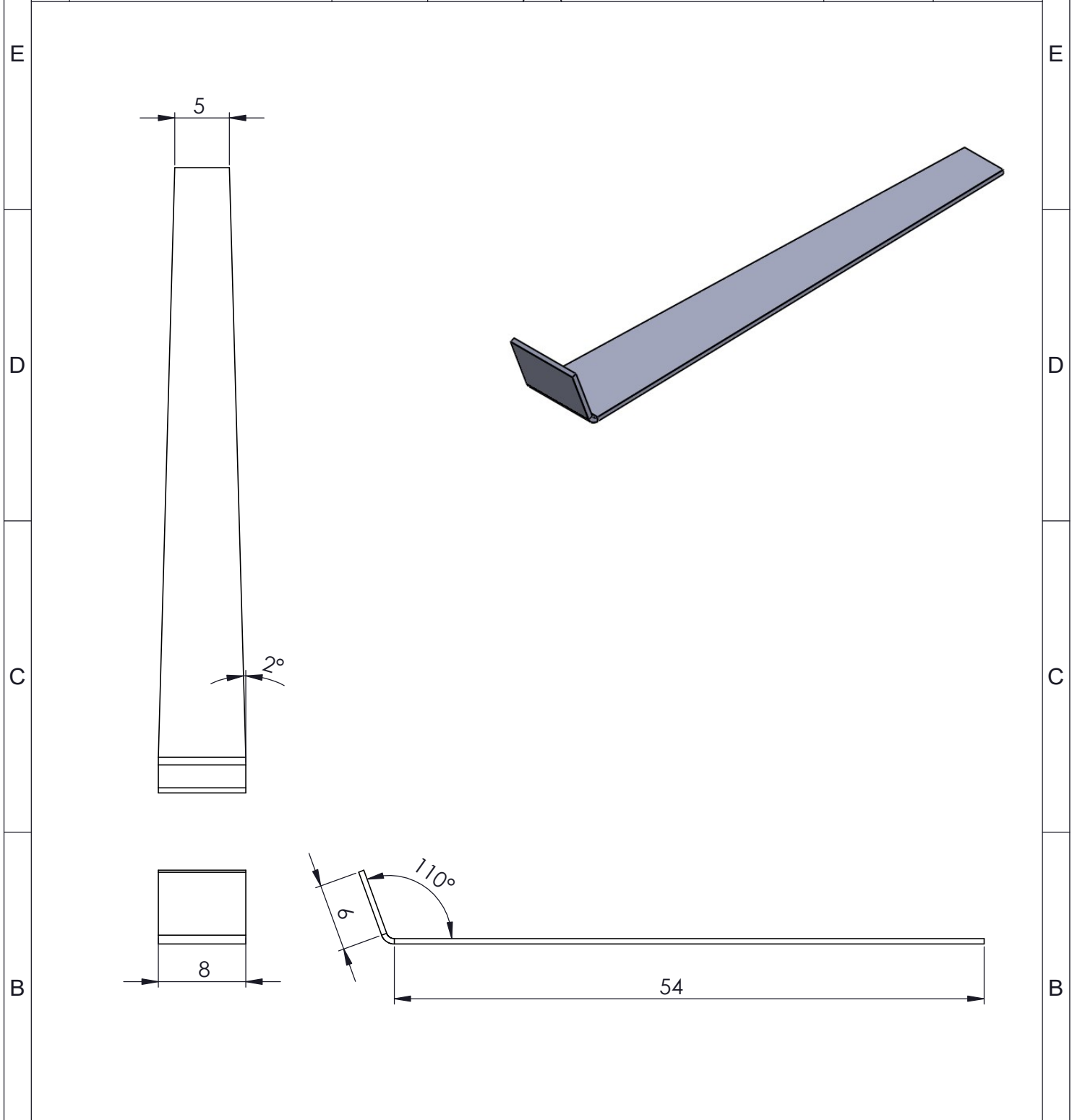

>	0	6	30	120	400	1000	UKURAN LANJUT	NO. ORDER	PROYEKSI		
<	6	30	120	400	1000	2000					
TOL	±0.1	±0.2	±0.3	±0.5	±0.8	±1.2			SKALA	DIGAMBAR	06-06-2022
NAMA : <h3 style="text-align: center;">BLADE PROFILE</h3>								2:1	DIPERIKSA		
									DISAHKAN		
NO. ASSY. :								FORMAT	JTM19-04-03-02		
POLITEKNIK NEGERI CILACAP, JURUSAN TEKNIK MESIN JL. dr. SOETOMO, NO. 01, SIDAKAYA, CILACAP, 53212 TELP : 0282 - 533329, E-mail : tmpnc@politeknikcilacap.ac.id								A4			