

LAMPIRAN 1

Biodata Penulis



Nama : Galuh Adi Setiawan
Tempat, tanggal lahir : Cilacap, 04 Juli 2001
NIM : 190103034
Jurusan : Teknik Mesin
Email : galuhadi040701@gmail.com
Alamat : Jl. Soekarno – Hatta RT 01/RW 02, Kec. Kesugihan, Kab. Cilacap
Hobi : Menggambar
Motto : Kesuksesan tak pernah dimiliki. Ia disewakan dan harus dibayar setiap harinya

Riwayat Pendidikan :

1. SD Negeri 1 Menganti (2007-2013)
2. SMP Negeri 7 Cilacap (2013-2016)
3. SMK Negeri 2 Cilacap (2016-2019)
4. Politeknik Negeri Cilacap (2019-2022)

LAMPIRAN 2

Tabel *safety factor* menurut (Sularso dan Suga, 2008)

Jenis bahan	Sf ₁	Sf ₂
Bahan Sf dengan kekuatan yang diijinkan	5,6	1,3-3,0
Bahan S-C dan baja paduan	6,0	1,3-3,0

LAMPIRAN 3

LAMPIRAN 4

5		4		3		2		1	
NO	PERUBAHAN	TANGGAL	NAMA	NO	PERUBAHAN	TANGGAL	NAMA		
				△					

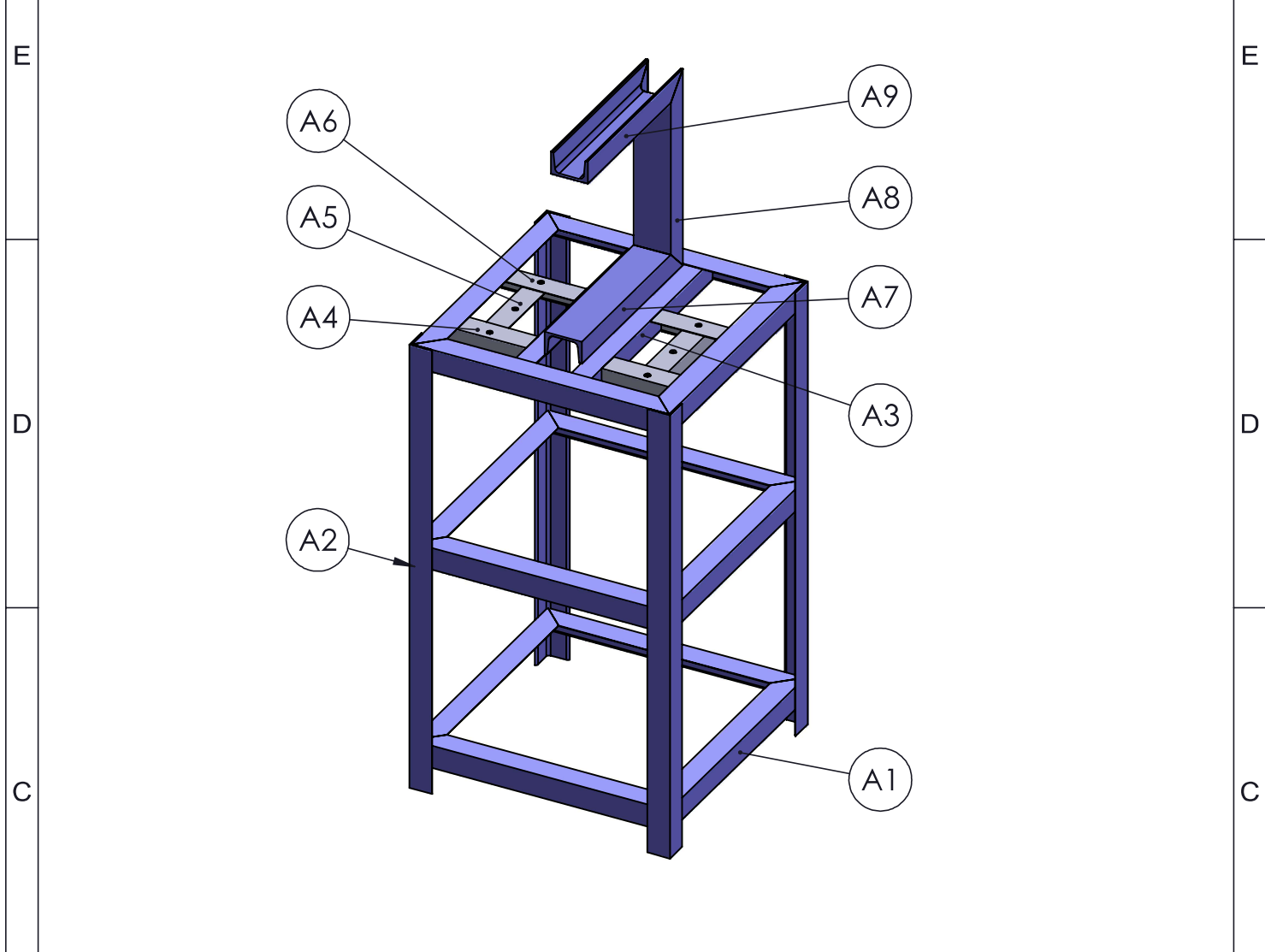

12	RANGKA SISI		SS400			A1	
4	RANGKA TEGAK		SS400			A2	
2	BRACKET KANAL U		SS400			A3	
2	BRACKET CETAKAN 1		SS400			A4	
2	BRACKET POST GUIDE		SS400			A5	
2	BRACKET CETAKAN 2		SS400			A6	
1	ALAS LENGAN		SS400			A7	
1	LENGAN TEGAK		SS400			A8	
1	BRACKET PNEUMATIK		SS400			A9	

JML	NAMA BAGIAN						POS	BAHAN	UKURAN JADI	UKURAN KASAR	NO. ID	F
>	0	6	30	120	400	1000	UKURAN LANJUT			NO. ORDER	PROYEKSI	
<	6	30	120	400	1000	2000						
TOL	±0.1	±0.2	±0.3	±0.5	±0.8	±1.2						

NAMA :				SKALA	DIGAMBAR	03-08-2022	GALUH
RANGKA				1:10	DIPERIKSA		AGUS
					DISAHKAN		
NO. ASSY. :							

POLITEKNIK NEGERI CILACAP, JURUSAN TEKNIK MESIN JL. dr. SOETOMO, NO. 01, SIDAKAYA, CILACAP, 53212 TELP : 0282 - 533329, E-mail :tmpnc@politeknikcilacap.ac.id				FORMAT			
				A4			

5		4		3		2		1	
---	--	---	--	---	--	---	--	---	--

PERUBAHAN DARI :

DIGANTI DENGAN :

5		4		3		2		1	
NO	PERUBAHAN	TANGGAL	NAMA	NO	PERUBAHAN	TANGGAL	NAMA		
				△					

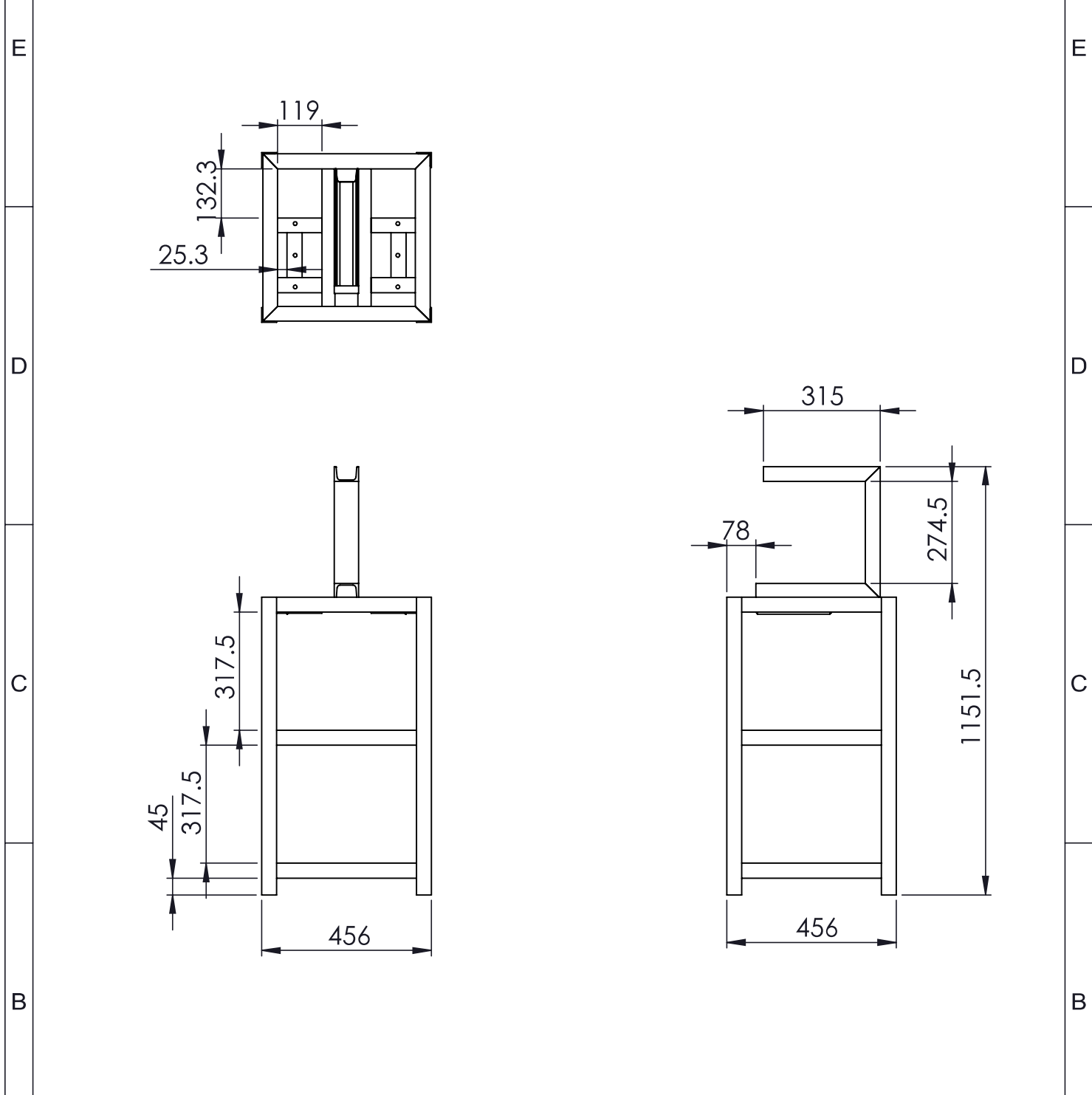

JML	NAMA BAGIAN						POS	BAHAN	UKURAN JADI	UKURAN KASAR	NO. ID	F
>	0	6	30	120	400	1000	UKURAN LANJUT			NO. ORDER	PROYEKSI	
<	6	30	120	400	1000	2000						
TOL	±0.1	±0.2	±0.3	±0.5	±0.8	±1.2						
NAMA : <p style="text-align: center;">RANGKA</p>										SKALA 1:15	DIGAMBAR 03-08-2022 DIPERIKSA DISAHKAN	GALUH AGUS
NO. ASSY. :										FORMAT A4		

5		4			3		2		1	
NO	PERUBAHAN	TANGGAL	NAMA	NO	PERUBAHAN	TANGGAL	NAMA			

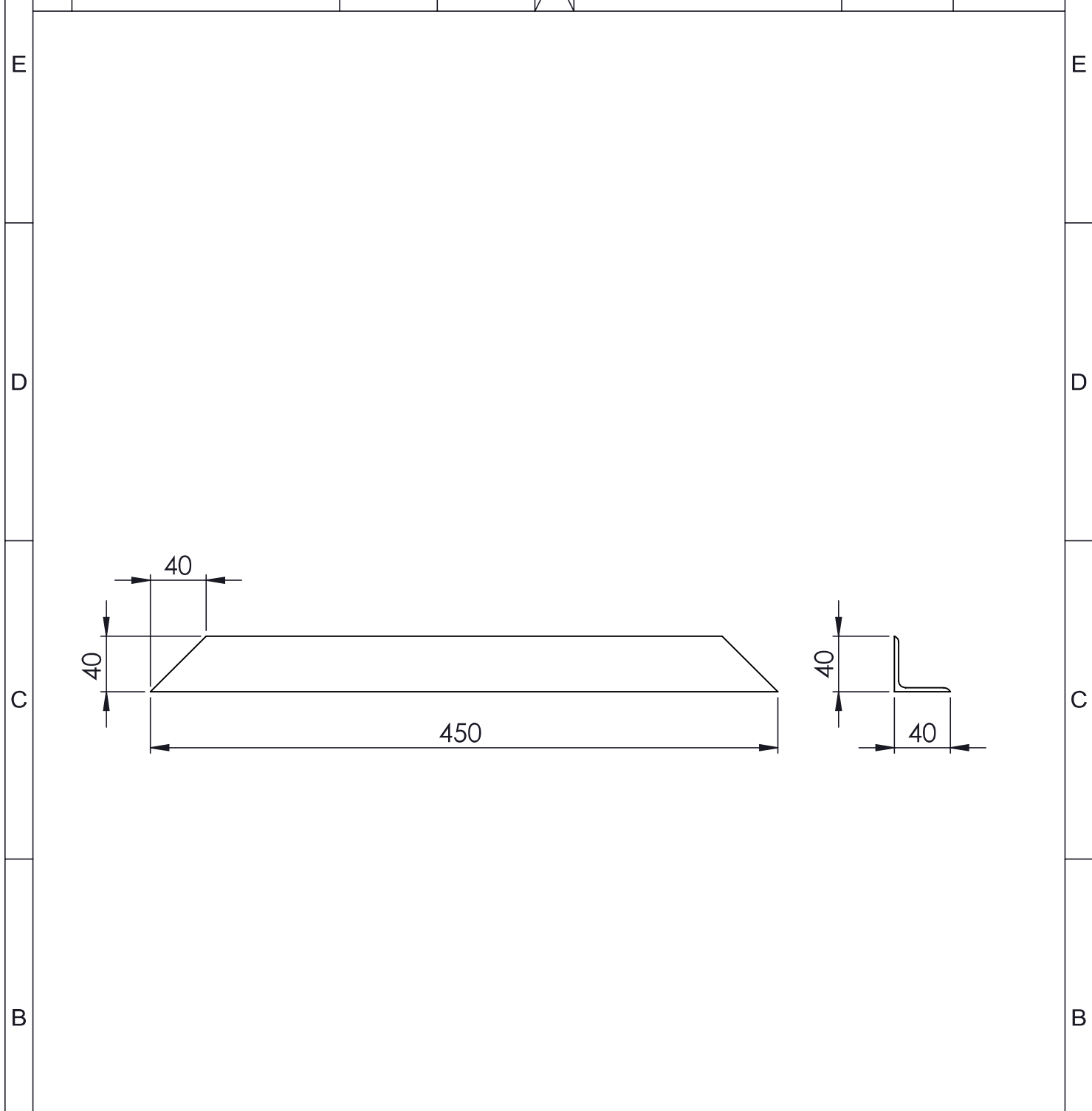

JML	NAMA BAGIAN					POS	BAHAN	UKURAN JADI	UKURAN KASAR	NO. ID	F
>	0	6	30	120	400	1000	UKURAN LANJUT		NO. ORDER	PROYEKSI	
<	6	30	120	400	1000	2000					
TOL	±0.1	±0.2	±0.3	±0.5	±0.8	±1.2					
NAMA :								SKALA	DIGAMBAR	03-08-2022	GALUH
RANGKA SISI								1:4	DIPERIKSA		AGUS
									DISAHKAN		
NO. ASSY. :								FORMAT			
POLITEKNIK NEGERI CILACAP, JURUSAN TEKNIK MESIN JL. dr. SOETOMO, NO. 01, SIDAKAYA, CILACAP, 53212 TELP : 0282 - 533329, E-mail : tmpnc@politeknikcilacap.ac.id								A4			

5		4			3		2		1	
---	--	---	--	--	---	--	---	--	---	--

PERUBAHAN DARI :

DIGANTI DENGAN :

5		4		3		2		1	
NO	PERUBAHAN	TANGGAL	NAMA	NO	PERUBAHAN	TANGGAL	NAMA		
				△					

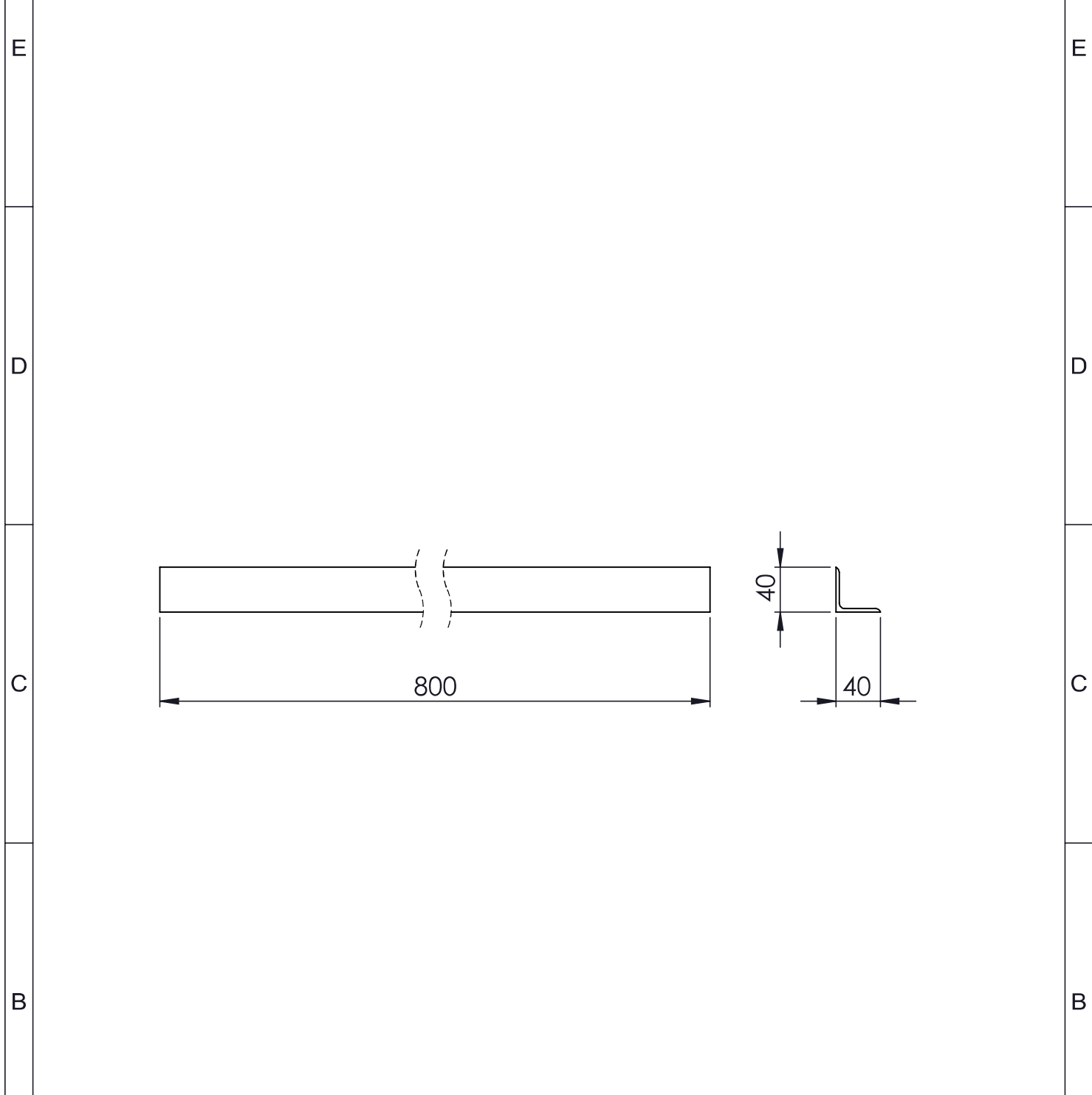

JML	NAMA BAGIAN					POS	BAHAN	UKURAN JADI	UKURAN KASAR	NO. ID	F
>	0	6	30	120	400	1000	UKURAN LANJUT	NO. ORDER	PROYEKSI		
<	6	30	120	400	1000	2000					
TOL	±0.1	±0.2	±0.3	±0.5	±0.8	±1.2					
NAMA :								SKALA	DIGAMBAR	03-08-2022	GALUH
RANGKA TEGAK								1:5	DIPERIKSA		AGUS
									DISAHKAN		
NO. ASSY. :								FORMAT			
POLITEKNIK NEGERI CILACAP, JURUSAN TEKNIK MESIN JL. dr. SOETOMO, NO. 01, SIDAKAYA, CILACAP, 53212 TELP : 0282 - 533329, E-mail : tmpnc@politeknikcilacap.ac.id								A4			

5		4			3		2		1	
NO	PERUBAHAN			TANGGAL	NAMA	NO	PERUBAHAN		TANGGAL	NAMA
						△				

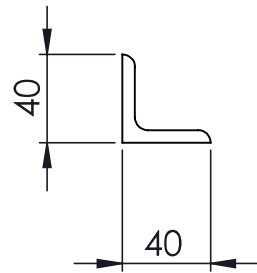
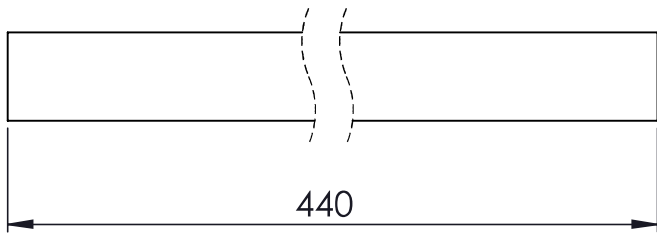

JML	NAMA BAGIAN						POS	BAHAN	UKURAN JADI	UKURAN KASAR	NO. ID	F	
>	0	6	30	120	400	1000	UKURAN LANJUT			NO. ORDER			
<	6	30	120	400	1000	2000							
TOL	±0.1	±0.2	±0.3	±0.5	±0.8	±1.2							
NAMA :									SKALA	DIGAMBAR	03-08-2022	GALUH	
BRACKET KANAL U									1:4	DIPERIKSA		AGUS	
										DISAHKAN			
NO. ASSY. :									FORMAT				
POLITEKNIK NEGERI CILACAP, JURUSAN TEKNIK MESIN JL. dr. SOETOMO, NO. 01, SIDAKAYA, CILACAP, 53212 TELP : 0282 - 533329, E-mail : tmpnc@politeknikcilacap.ac.id									A4				

5		4			3		2		1	
NO	PERUBAHAN	TANGGAL	NAMA	NO	PERUBAHAN	TANGGAL	NAMA			
				△						

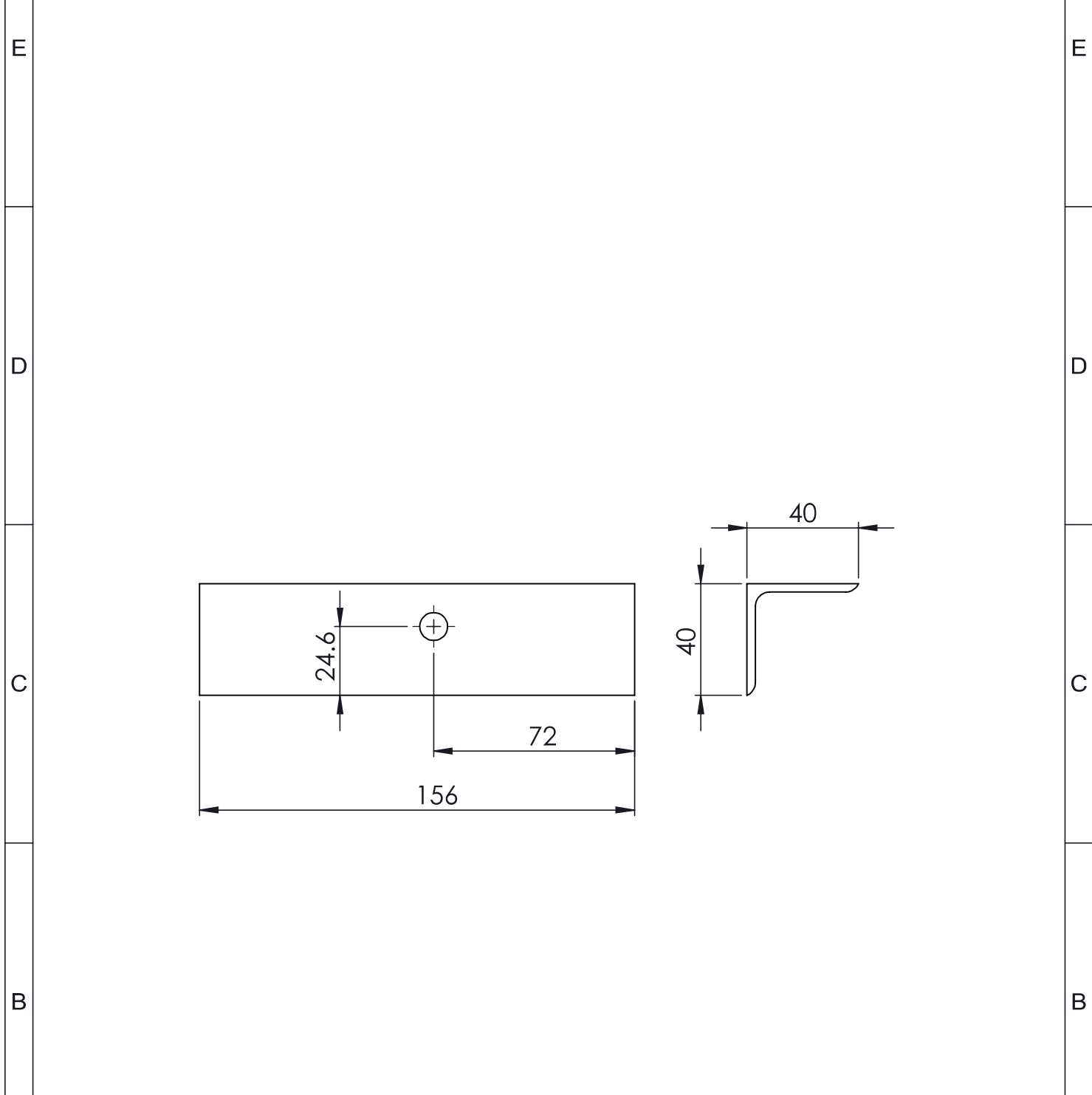

JML	NAMA BAGIAN					POS	BAHAN	UKURAN JADI	UKURAN KASAR	NO. ID	F
>	0	6	30	120	400	1000	UKURAN LANJUT		NO. ORDER	PROYEKSI	
<	6	30	120	400	1000	2000					
TOL	±0.1	±0.2	±0.3	±0.5	±0.8	±1.2					
NAMA :								SKALA	DIGAMBAR	03-08-2022	GALUH
BRACKET CETAKAN 1								1:2	DIPERIKSA		AGUS
									DISAHKAN		
NO. ASSY. :								FORMAT			
POLITEKNIK NEGERI CILACAP, JURUSAN TEKNIK MESIN JL. dr. SOETOMO, NO. 01, SIDAKAYA, CILACAP, 53212 TELP : 0282 - 533329, E-mail : tmpnc@politeknikcilacap.ac.id								A4			

5		4			3		2		1	
NO	PERUBAHAN			TANGGAL	NAMA	NO	PERUBAHAN		TANGGAL	NAMA
						△				

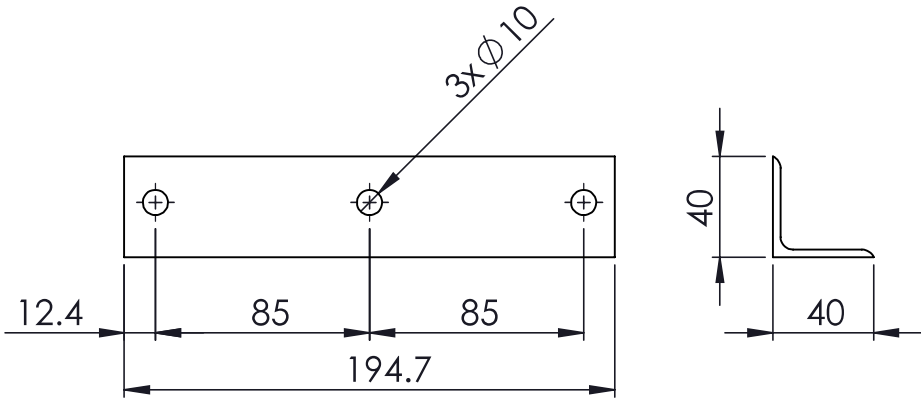

JML	NAMA BAGIAN					POS	BAHAN	UKURAN JADI	UKURAN KASAR	NO. ID	F
>	0	6	30	120	400	1000	UKURAN LANJUT		NO. ORDER	PROYEKSI	
<	6	30	120	400	1000	2000					
TOL	±0.1	±0.2	±0.3	±0.5	±0.8	±1.2					
NAMA :								SKALA	DIGAMBAR	03-08-2022	GALUH
BRACKET POST GUIDE								1:3	DIPERIKSA		AGUS
									DISAHKAN		
NO. ASSY. :									FORMAT		
POLITEKNIK NEGERI CILACAP, JURUSAN TEKNIK MESIN JL. dr. SOETOMO, NO. 01, SIDAKAYA, CILACAP, 53212 TELP : 0282 - 533329, E-mail : tmpnc@politeknikcilacap.ac.id								A4			

5		4			3		2		1	
NO	PERUBAHAN			TANGGAL	NAMA	NO	PERUBAHAN		TANGGAL	NAMA
						△				

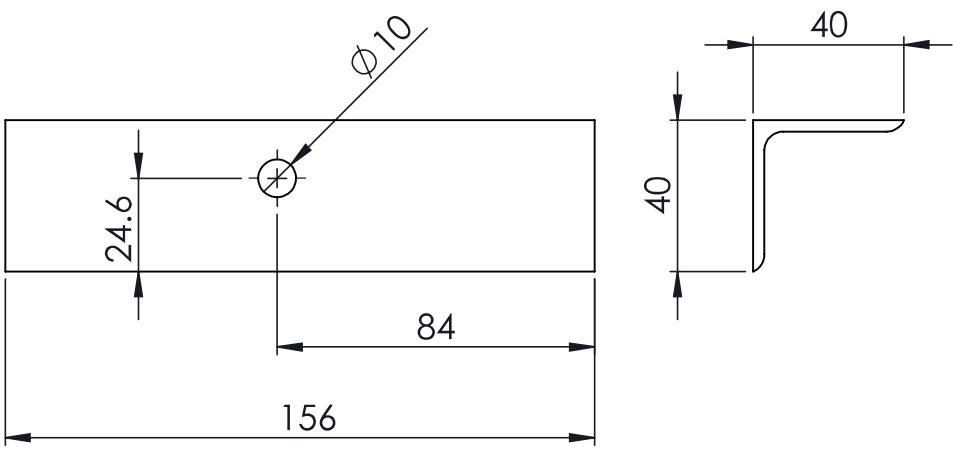

JML	NAMA BAGIAN					POS	BAHAN	UKURAN JADI	UKURAN KASAR	NO. ID	F	
>	0	6	30	120	400	1000	UKURAN LANJUT		NO. ORDER	PROYEKSI 		
<	6	30	120	400	1000	2000						
TOL	±0.1	±0.2	±0.3	±0.5	±0.8	±1.2						
NAMA :									SKALA	DIGAMBAR	03-08-2022	GALUH
BRACKET CETAKAN 2									1:3	DIPERIKSA		AGUS
										DISAHKAN		
NO. ASSY. :									FORMAT			
POLITEKNIK NEGERI CILACAP, JURUSAN TEKNIK MESIN JL. dr. SOETOMO, NO. 01, SIDAKAYA, CILACAP, 53212 TELP : 0282 - 533329, E-mail : tmpnc@politeknikcilacap.ac.id									A4			

5		4			3		2		1			
NO	PERUBAHAN			TANGGAL	NAMA	NO	PERUBAHAN		TANGGAL	NAMA		
						△						
JML	NAMA BAGIAN					POS	BAHAN	UKURAN JADI	UKURAN KASAR	NO. ID	F	
>	0	6	30	120	400	1000	UKURAN LANJUT	NO. ORDER	PROYEKSI			
<	6	30	120	400	1000	2000						
TOL	±0.1	±0.2	±0.3	±0.5	±0.8	±1.2						
NAMA :								SKALA	DIGAMBAR	03-08-2022	GALUH	
ALAS LENGAN									1:3	DIPERIKSA		AGUS
										DISAHKAN		
NO. ASSY. :								FORMAT				
POLITEKNIK NEGERI CILACAP, JURUSAN TEKNIK MESIN JL. dr. SOETOMO, NO. 01, SIDAKAYA, CILACAP, 53212 TELP : 0282 - 533329, E-mail : tmpnc@politeknikcilacap.ac.id								A4				

PERUBAHAN DARI :

DIGANTI DENGAN :

5		4		3		2		1	
NO	PERUBAHAN	TANGGAL	NAMA	NO	PERUBAHAN	TANGGAL	NAMA		
				△					

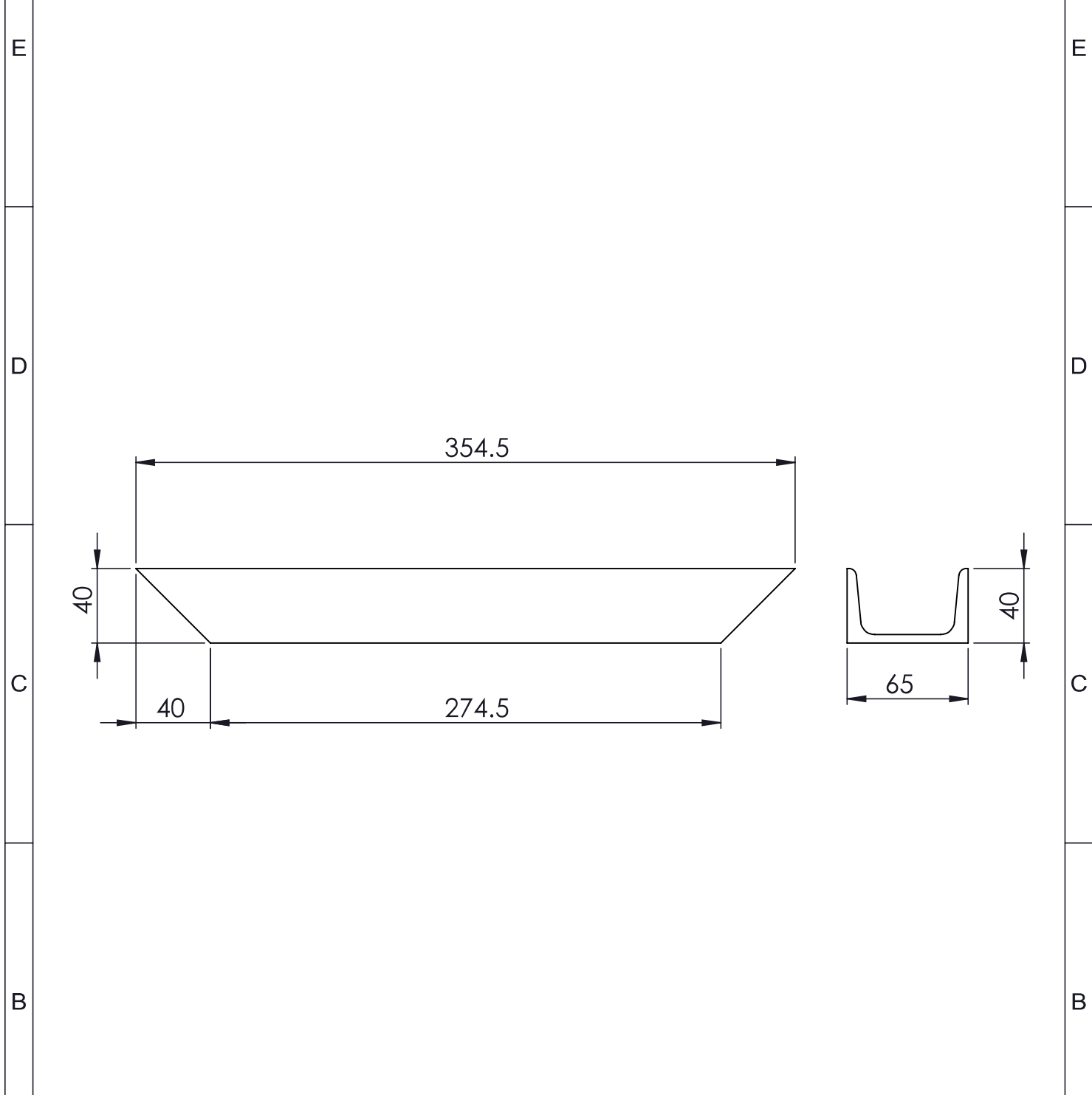

JML	NAMA BAGIAN					POS	BAHAN	UKURAN JADI	UKURAN KASAR	NO. ID	F
>	0	6	30	120	400	1000	UKURAN LANJUT		NO. ORDER	PROYEKSI	
<	6	30	120	400	1000	2000					
TOL	±0.1	±0.2	±0.3	±0.5	±0.8	±1.2					
NAMA :								SKALA	DIGAMBAR	03-08-2022	GALUH
LENGAN TEGAK								1:3	DIPERIKSA		AGUS
									DISAHKAN		
NO. ASSY. :									FORMAT		
POLITEKNIK NEGERI CILACAP, JURUSAN TEKNIK MESIN JL. dr. SOETOMO, NO. 01, SIDAKAYA, CILACAP, 53212 TELP : 0282 - 533329, E-mail : tmpnc@politeknikcilacap.ac.id								A4			

5		4		3		2		1	
NO	PERUBAHAN	TANGGAL	NAMA	NO	PERUBAHAN	TANGGAL	NAMA		
				△					

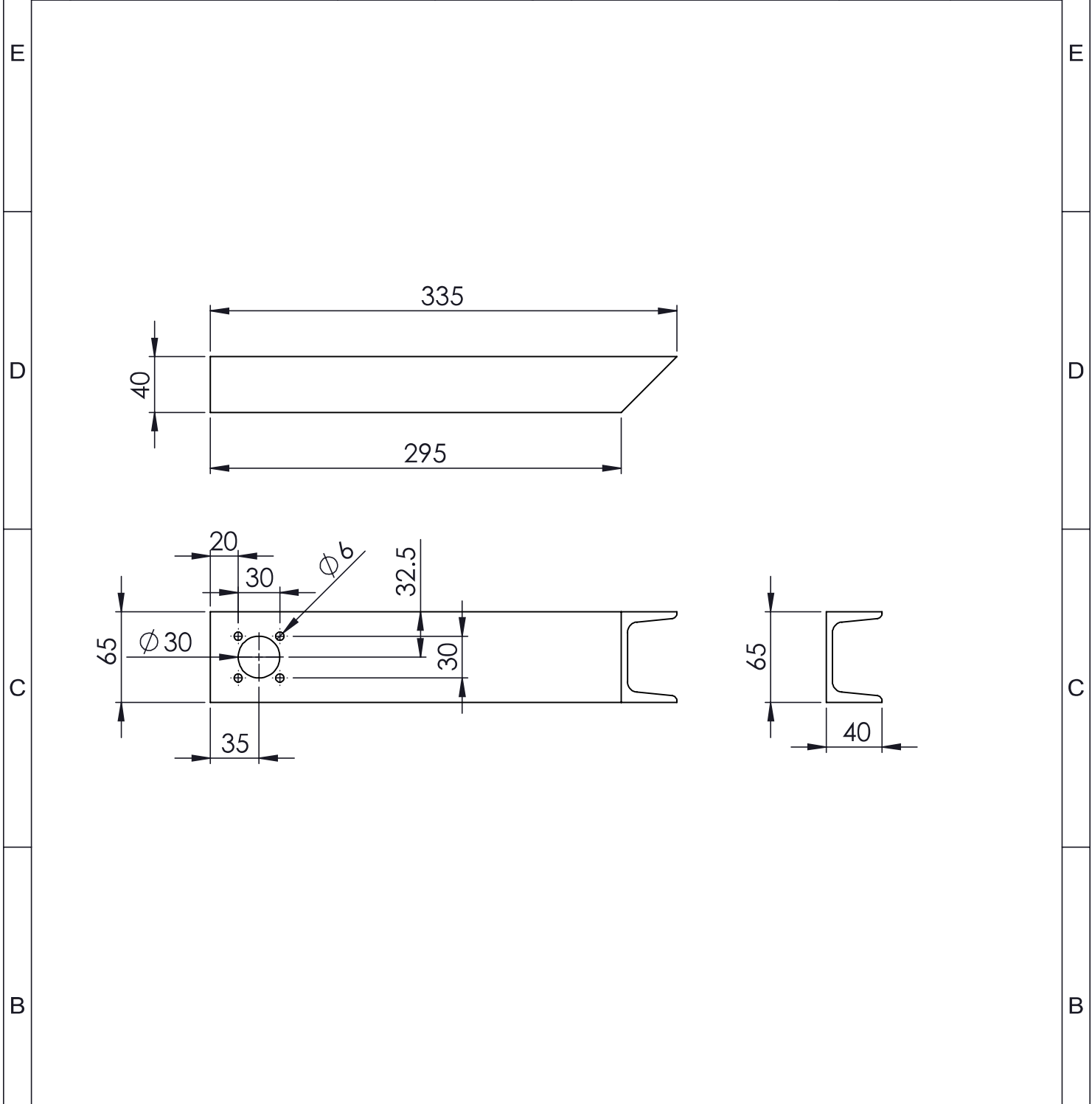

JML	NAMA BAGIAN					POS	BAHAN	UKURAN JADI	UKURAN KASAR	NO. ID	F	
>	0	6	30	120	400	1000	UKURAN LANJUT		NO. ORDER	PROYEKSI		
<	6	30	120	400	1000	2000						
TOL	±0.1	±0.2	±0.3	±0.5	±0.8	±1.2						
NAMA :									SKALA	DIGAMBAR	03-08-2022	GALUH
<p align="center">BRACKET PNEUMATIK</p>									1:3	DIPERIKSA		AGUS
										DISAHKAN		
NO. ASSY. :									FORMAT			
POLITEKNIK NEGERI CILACAP, JURUSAN TEKNIK MESIN JL. dr. SOETOMO, NO. 01, SIDAKAYA, CILACAP, 53212 TELP : 0282 - 533329, E-mail : tmpnc@politeknikcilacap.ac.id									A4			

5		4		3		2		1	
NO	PERUBAHAN	TANGGAL	NAMA	NO	PERUBAHAN	TANGGAL	NAMA		
				△					

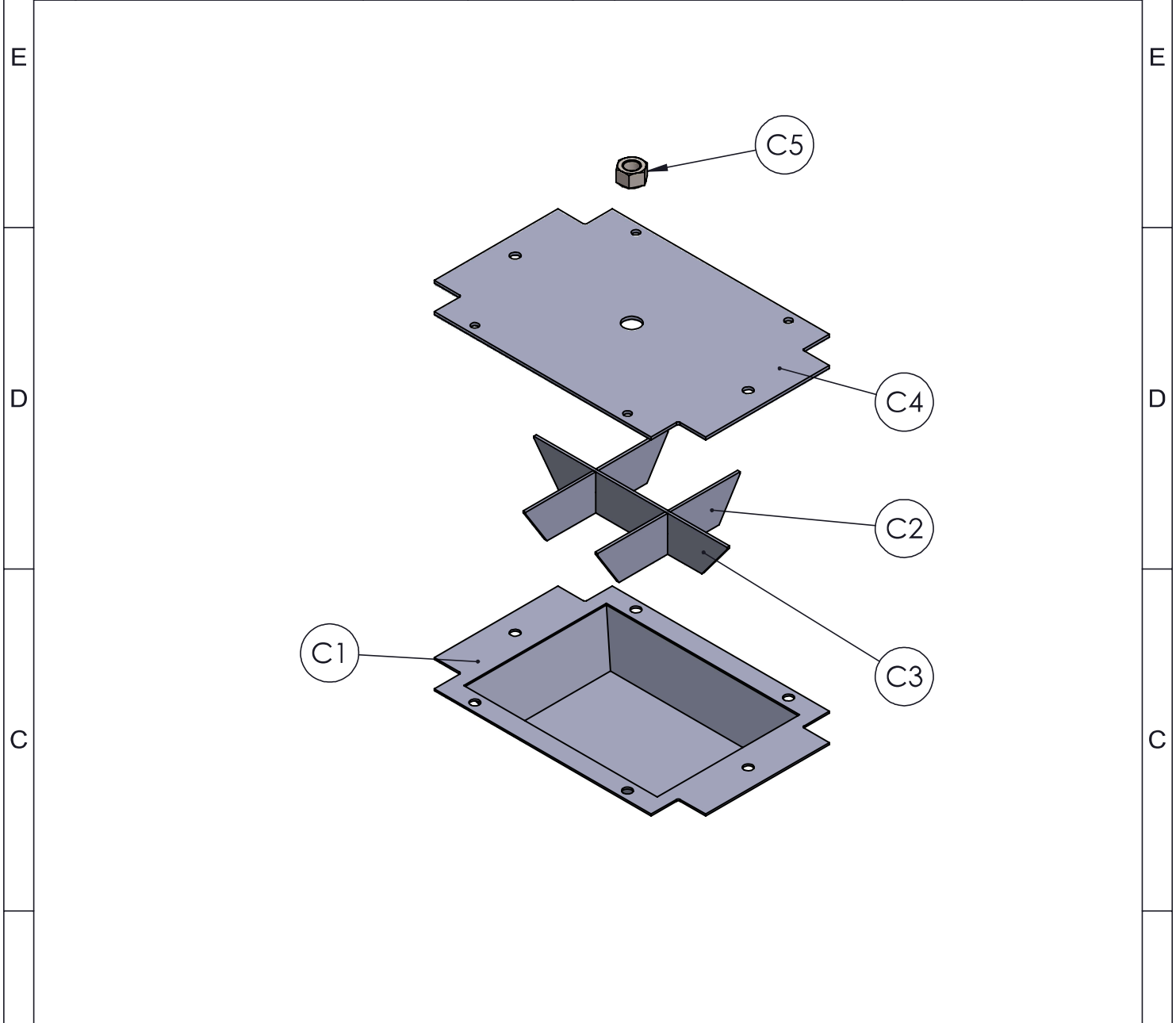

1	PLAT ATAS		Al			C1	
2	FIN MELINTANG		Al			C2	
1	FIN MEMANJANG		Al			C3	
1	TUTUP ATAS		Al			C4	
1	NUT		-			C5	

JML	NAMA BAGIAN						POS	BAHAN	UKURAN JADI	UKURAN KASAR	NO. ID	F
>	0	6	30	120	400	1000	UKURAN LANJUT		NO. ORDER	PROYEKSI		
<	6	30	120	400	1000	2000						
TOL	±0.1	±0.2	±0.3	±0.5	±0.8	±1.2						

NAMA :								SKALA	DIGAMBAR	03-08-2022	GALUH
CETAKAN ATAS								1:5	DIPERIKSA		AGUS
									DISAHKAN		

NO. ASSY. :								FORMAT			
POLITEKNIK NEGERI CILACAP, JURUSAN TEKNIK MESIN JL. dr. SOETOMO, NO. 01, SIDAKAYA, CILACAP, 53212 TELP : 0282 - 533329, E-mail : tmpnc@politeknikcilacap.ac.id								A4			

5		4		3		2		1	
---	--	---	--	---	--	---	--	---	--

PERUBAHAN DARI :

DIGANTI DENGAN :

5		4			3		2		1	
NO	PERUBAHAN	TANGGAL	NAMA	NO	PERUBAHAN	TANGGAL	NAMA			
				△						

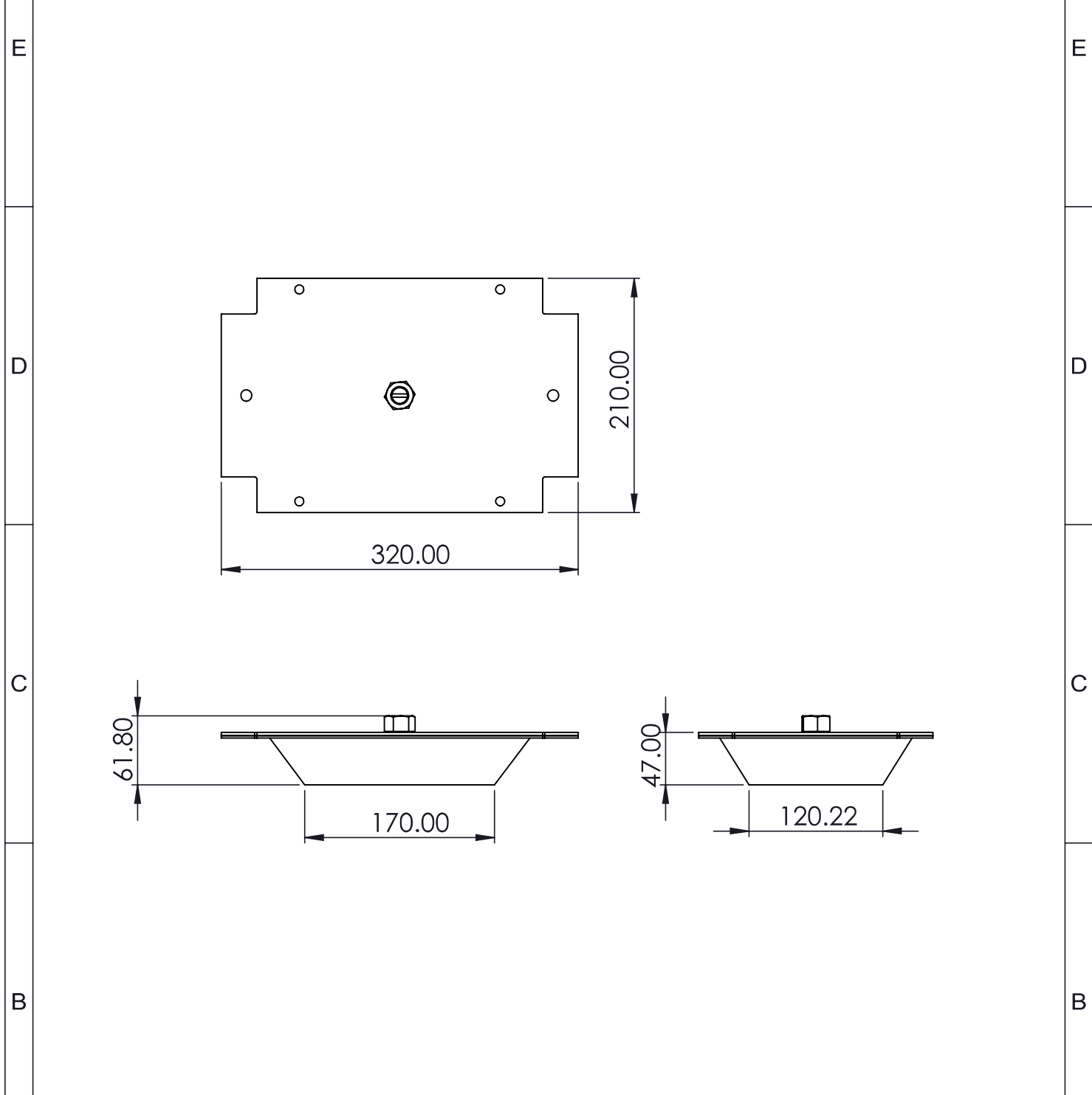

JML	NAMA BAGIAN					POS	BAHAN	UKURAN JADI	UKURAN KASAR	NO. ID	F
>	0	6	30	120	400	1000	UKURAN LANJUT		NO. ORDER		
<	6	30	120	400	1000	2000					
TOL	±0.1	±0.2	±0.3	±0.5	±0.8	±1.2					
NAMA : <h2 style="text-align: center;">CETAKAN ATAS</h2>								SKALA	DIGAMBAR	03-08-2022	GALUH
								1:5	DIPERIKSA		AGUS
									DISAHKAN		
NO. ASSY. : POLITEKNIK NEGERI CILACAP, JURUSAN TEKNIK MESIN JL. dr. SOETOMO, NO. 01, SIDAKAYA, CILACAP, 53212 TELP : 0282 - 533329, E-mail : tmpnc@politeknikcilacap.ac.id								FORMAT			
								A4			

5		4			3		2		1	
NO	PERUBAHAN	TANGGAL	NAMA	NO	PERUBAHAN	TANGGAL	NAMA			

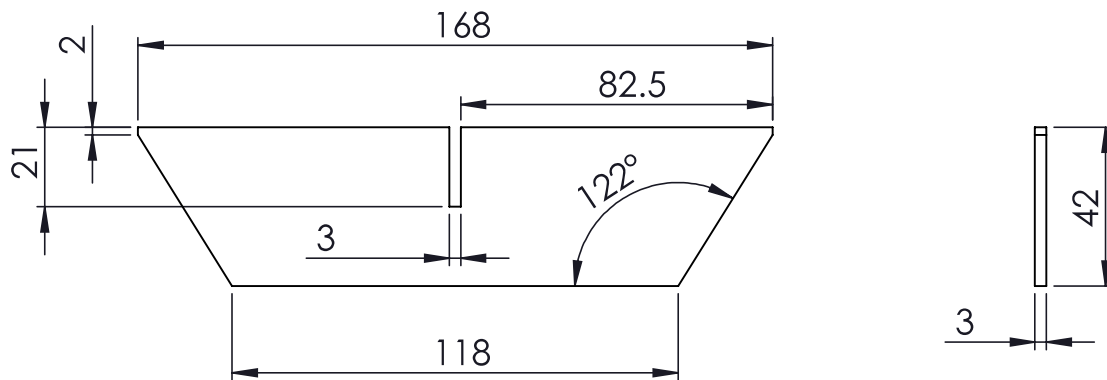

JML	NAMA BAGIAN						POS	BAHAN	UKURAN JADI	UKURAN KASAR	NO. ID	F
>	0	6	30	120	400	1000	UKURAN LANJUT			NO. ORDER	PROYEKSI	
<	6	30	120	400	1000	2000						
TOL	±0.1	±0.2	±0.3	±0.5	±0.8	±1.2						

NAMA :								SKALA	DIGAMBAR	03-08-2022	GALUH
FIN MELINTANG								1:5	DIPERIKSA		AGUS
									DISAHKAN		
NO. ASSY. :											

	POLITEKNIK NEGERI CILACAP, JURUSAN TEKNIK MESIN							FORMAT			
	JL. dr. SOETOMO, NO. 01, SIDAKAYA, CILACAP, 53212							A4			
TELP : 0282 - 533329, E-mail : tmpnc@politeknikcilacap.ac.id											

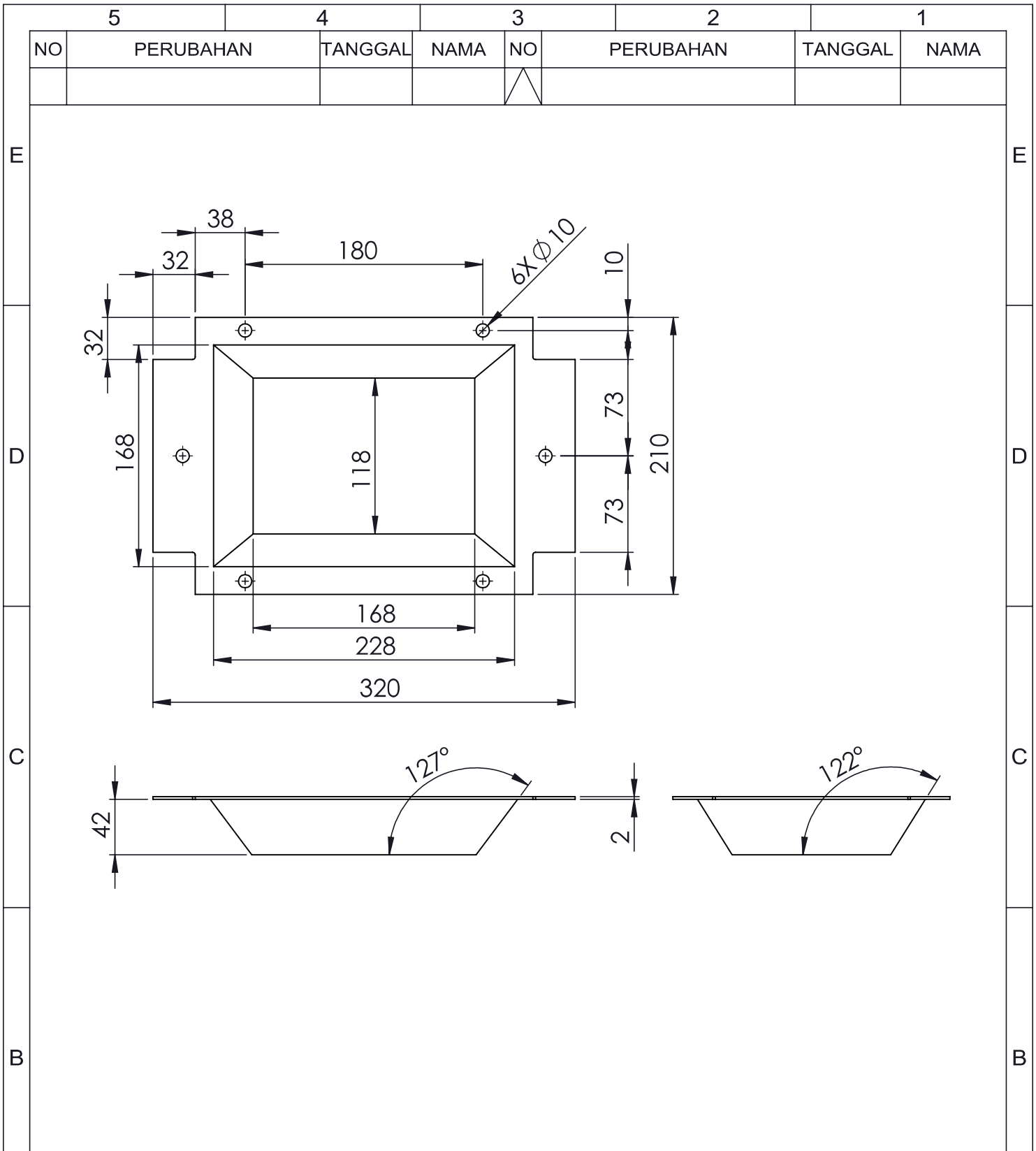

JML	NAMA BAGIAN					POS	BAHAN	UKURAN JADI	UKURAN KASAR	NO. ID	F
>	0	6	30	120	400	1000	UKURAN LANJUT		NO. ORDER	PROYEKSI	
<	6	30	120	400	1000	2000					
TOL	±0.1	±0.2	±0.3	±0.5	±0.8	±1.2					
NAMA :								SKALA	DIGAMBAR	03-08-2022	GALUH
BASE CETAKAN ATAS								1:5	DIPERIKSA		AGUS
									DISAHKAN		
NO. ASSY. :								FORMAT			
POLITEKNIK NEGERI CILACAP, JURUSAN TEKNIK MESIN JL. dr. SOETOMO, NO. 01, SIDAKAYA, CILACAP, 53212 TELP : 0282 - 533329, E-mail : tmpnc@politeknikcilacap.ac.id								A4			

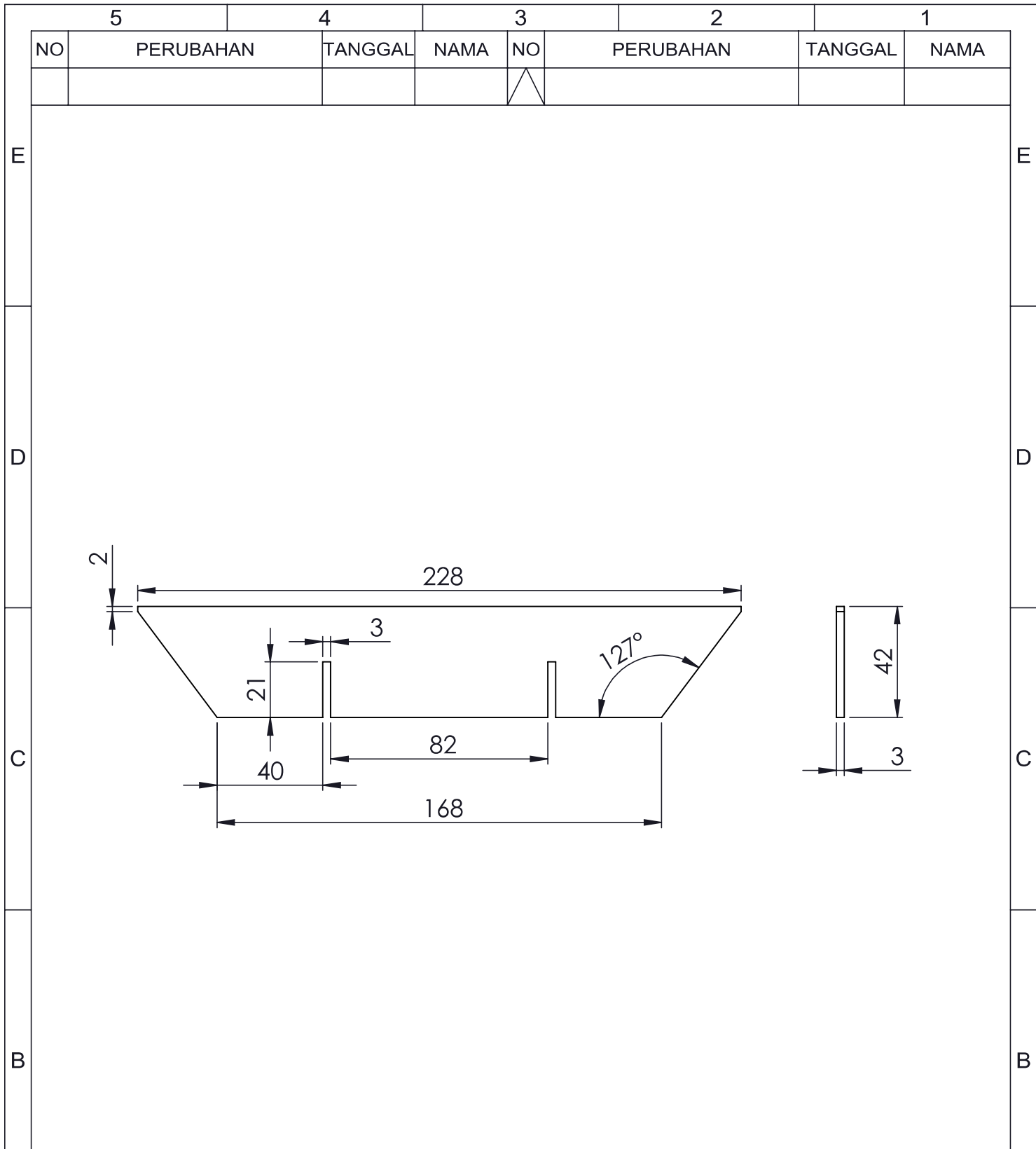

JML	NAMA BAGIAN						POS	BAHAN	UKURAN JADI	UKURAN KASAR	NO. ID	F
>	0	6	30	120	400	1000	UKURAN LANJUT		NO. ORDER	PROYEKSI		
<	6	30	120	400	1000	2000						
TOL	±0.1	±0.2	±0.3	±0.5	±0.8	±1.2						
NAMA :									SKALA	DIGAMBAR	03-08-2022	GALUH
FIN MEMANJANG									1:5	DIPERIKSA		AGUS
										DISAHKAN		
NO. ASSY. :									FORMAT			
POLITEKNIK NEGERI CILACAP, JURUSAN TEKNIK MESIN JL. dr. SOETOMO, NO. 01, SIDAKAYA, CILACAP, 53212 TELP : 0282 - 533329, E-mail : tmpnc@politeknikcilacap.ac.id									A4			

PERUBAHAN DARI :

DIGANTI DENGAN :

5		4		3		2		1	
NO	PERUBAHAN	TANGGAL	NAMA	NO	PERUBAHAN	TANGGAL	NAMA		
				△					

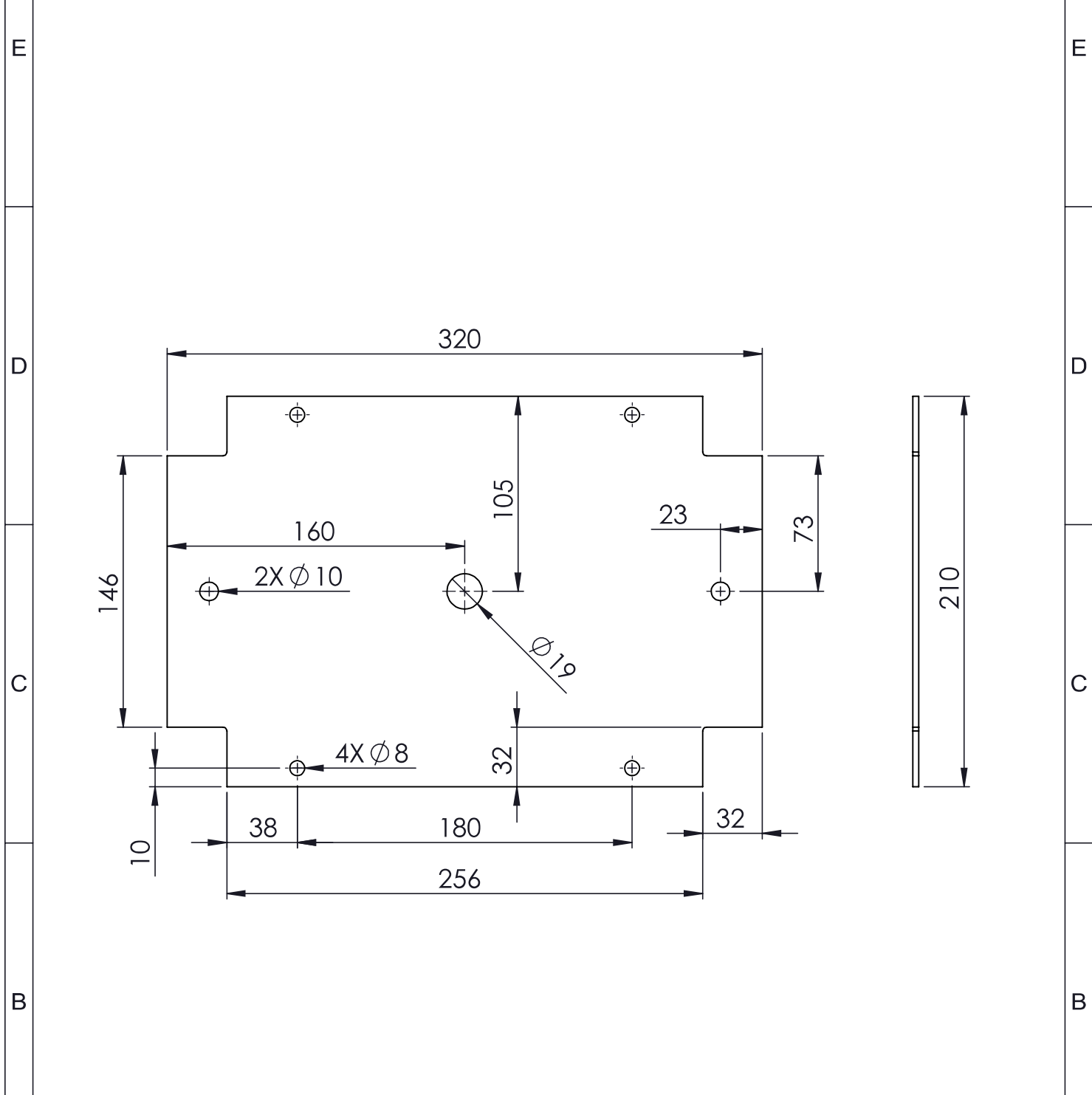

JML	NAMA BAGIAN					POS	BAHAN	UKURAN JADI	UKURAN KASAR	NO. ID	F
>	0	6	30	120	400	1000	UKURAN LANJUT		NO. ORDER	PROYEKSI	
<	6	30	120	400	1000	2000					
TOL	±0.1	±0.2	±0.3	±0.5	±0.8	±1.2					

NAMA : <h2 style="text-align: center;">TUTUP CETAKAN ATAS</h2>	SKALA <h1 style="text-align: center;">1:5</h1>	DIGAMBAR	03-08-2022	GALUH
		DIPERIKSA		AGUS
		DISAHKAN		

POLITEKNIK NEGERI CILACAP, JURUSAN TEKNIK MESIN JL. dr. SOETOMO, NO. 01, SIDAKAYA, CILACAP, 53212 TELP : 0282 - 533329, E-mail : tmpnc@politeknikcilacap.ac.id	FORMAT <h1 style="text-align: center;">A4</h1>			
--	---	--	--	--

5		4		3		2		1	
---	--	---	--	---	--	---	--	---	--

PERUBAHAN DARI :

DIGANTI DENGAN :

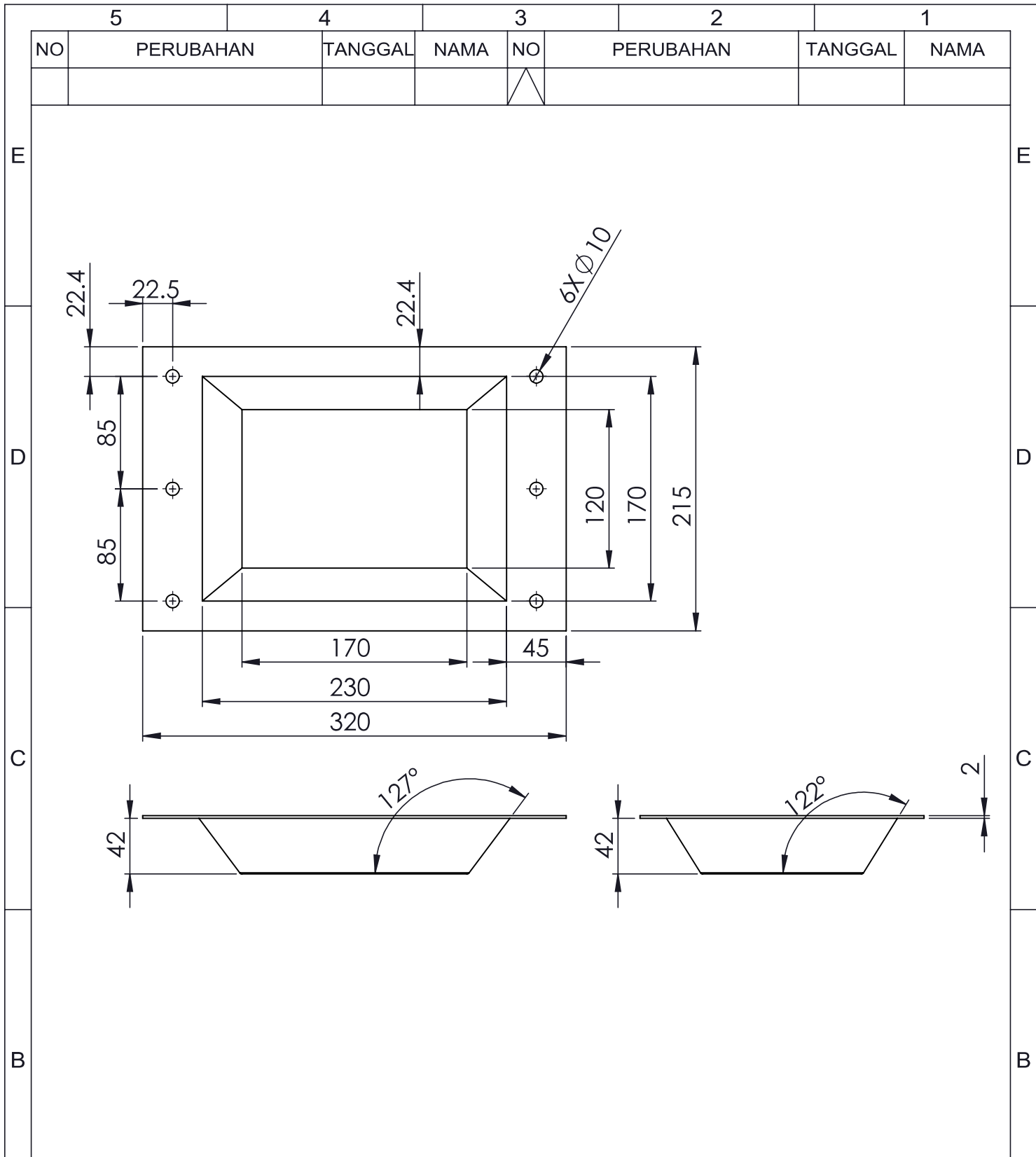





JML	NAMA BAGIAN					POS	BAHAN	UKURAN JADI	UKURAN KASAR	NO. ID	F
>	0	6	30	120	400	1000	UKURAN LANJUT	NO. ORDER	PROYEKSI		
<	6	30	120	400	1000	2000					
TOL	±0.1	±0.2	±0.3	±0.5	±0.8	±1.2					
NAMA :								SKALA 1:5	DIGAMBAR	03-08-2022	GALUH
CETAKAN BAWAH									DIPERIKSA		AGUS
									DISAHKAN		
NO. ASSY. :								FORMAT			
POLITEKNIK NEGERI CILACAP, JURUSAN TEKNIK MESIN JL. dr. SOETOMO, NO. 01, SIDAKAYA, CILACAP, 53212 TELP : 0282 - 533329, E-mail : tmpnc@politeknikcilacap.ac.id								A4			





PERUBAHAN DARI :

DIGANTI DENGAN :

LAMPIRAN 4

Proses Pembuatan Bahan *Biofoam*

No.	Proses	Visual	Alat bahan
1.	Siapkan alat dan bahan		Gelas beker, timbangan, sekam padi, saringan 100 mesh, KOH, etanol, lumping porselen, kertas lakmus, magnesium stearate, kitosan, dan lain- lain.
2.	Lakukan proses pengayakan dengan ukuran 100 mesh pada sekam padi.		Ayakan ukuran 100 mesh
3.	Lakukan maserasi sekam padi selama 7 hari menggunakan etanol 98% dan dilakukan penggantian etanol secara rutin setiap 2 hari sekali		Etanol dan wadah.
4.	Setelah 7 hari dilakukan proses penetralan hasil sekam padi yang telah direndam dengan membilas sekam padi dengan air panas selama 10 kali sampe bening air bilasnya lalu dicek dengan kertas lakmus		Air panas dan kertas lakmus
5.	Dilakukan proses delignifikasi penghilangan lignin menggunakan KOH 10%		Gelas beker, KOH 10%
7.	Selanjutnya di lakukan pemerasan bahan agar dapat menghilangkan KOH.		Kain.
8.	Dilakukan pengeringan sekam padi yang sudah dinetralisir dengan oven atau panas matahari		Oven

			
9.	Kemudian dihaluskan menggunakan lumpang porselen atau blender agar lebih cepat		Lumpang porselen.
10.	Siapkan kitosan yang sudah dicampur dengan aquades		Kitosan, aquades
11.	Campurkan kitosan dengan sekam padi yang sudah di haluskan ditambahkan asam asetat dan sorbitol		Kitosan, sekam padi, asam asetat, sorbitol
12.	Bahan siap dilakukan pencetakan		