

LAMPIRAN 1

Spesifikasi motor penggerak

No	Spesifikasi motor	Nilai	Satuan
1	Daya	746	Watt
2	Kecepatan putar	1400	Rpm
3	Torsi	5,1	Nm
4	Massa	10,5	Kg

LAMPIRAN 2

Material untuk poros

Lambang	Sifat mekanis		
	Batas mulur (kg/mm ²)	Kekuatan tarik (kg/mm ²)	Kekerasan (H _B)
S30C	29	48	137 - 197
S35C	31	52	149 - 207
S40C	33	55	156 - 217
S45C	35	58	169 - 229
S50C	37	62	179 - 235
S55C	40	66	185 - 285

LAMPIRAN 3

Katalog bantalan

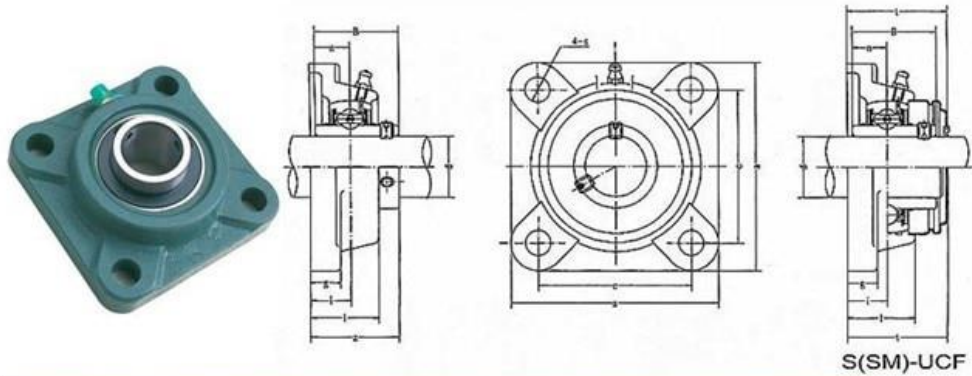

Bearing Numbers		Size											Bolt	weight
new code	old code	d	a	e	i	g	l	s	z	t	B	n		(kg)
UCF201	F90501	12	86	64	15	12	25.5	12	33.3	37.5	31	12.7	M10	0.6
UCF202	F60502	15	86	64	15	12	25.5	12	33.3	37.5	31	12.7	M10	0.59
UCF203	F90503	17	86	64	15	12	25.5	12	33.3	37.5	31	12.7	M10	0.58
UCF204	F90504	20	86	64	15	12	25.5	12	33.3	37.5	34.1	14.3	M10	0.56
UCF205	F90505	25	95	70	16	14	27	12	35.8	40	34.1	14.3	M10	0.8
UCF206	F90506	30	108	83	18	14	31	12	40.2	44.5	38.1	15.9	M10	1.12
UCF207	F90507	35	117	92	19	16	34	14	44.4	48.5	42.9	17.5	M12	1.46
UCF208	F90508	40	130	102	21	16	36	16	51.2	55.5	49.2	19	M14	1.84
UCF209	F90509	45	137	105	22	18	38	16	52.2	56.5	49.2	19	M14	2.15
UCF210	F90510	50	143	111	22	18	40	16	54.6	59.5	51.6	19	M16	2.42
UCF211	F90511	55	162	130	25	20	43	19	58.4	63	55.6	22.2	M16	3.31
UCF212	F90512	60	175	143	29	20	48	19	68.7	73.5	65.1	25.4	M16	4.28
UCF213	F90513	65	187	149	30	22	50	19	69.7	74.5	65.1	25.4	M16	4.99
UCF214	F90514	70	193	152	31	22	54	19	75.4	81.5	74.6	30.2	M16	5.85
UCF215	F90515	75	200	159	34	22	56	19	78.5	83.5	77.8	33.3	M16	6.91
UCF216	F90516	80	208	165	34	22	58	23	83.3	88.5	82.6	33.3	M20	7.5
UCF217	F90517	85	220	175	36	24	63	23	87.6	92.6	85.7	34.1	M20	9.66
UCF218	F90518	90	235	187	40	24	68	23	96.3	101.5	96	39.7	M20	12.06

LAMPIRAN 4

5		4		3		2		1	
NO	PERUBAHAN	TANGGAL	NAMA	NO	PERUBAHAN	TANGGAL	NAMA		
				△					

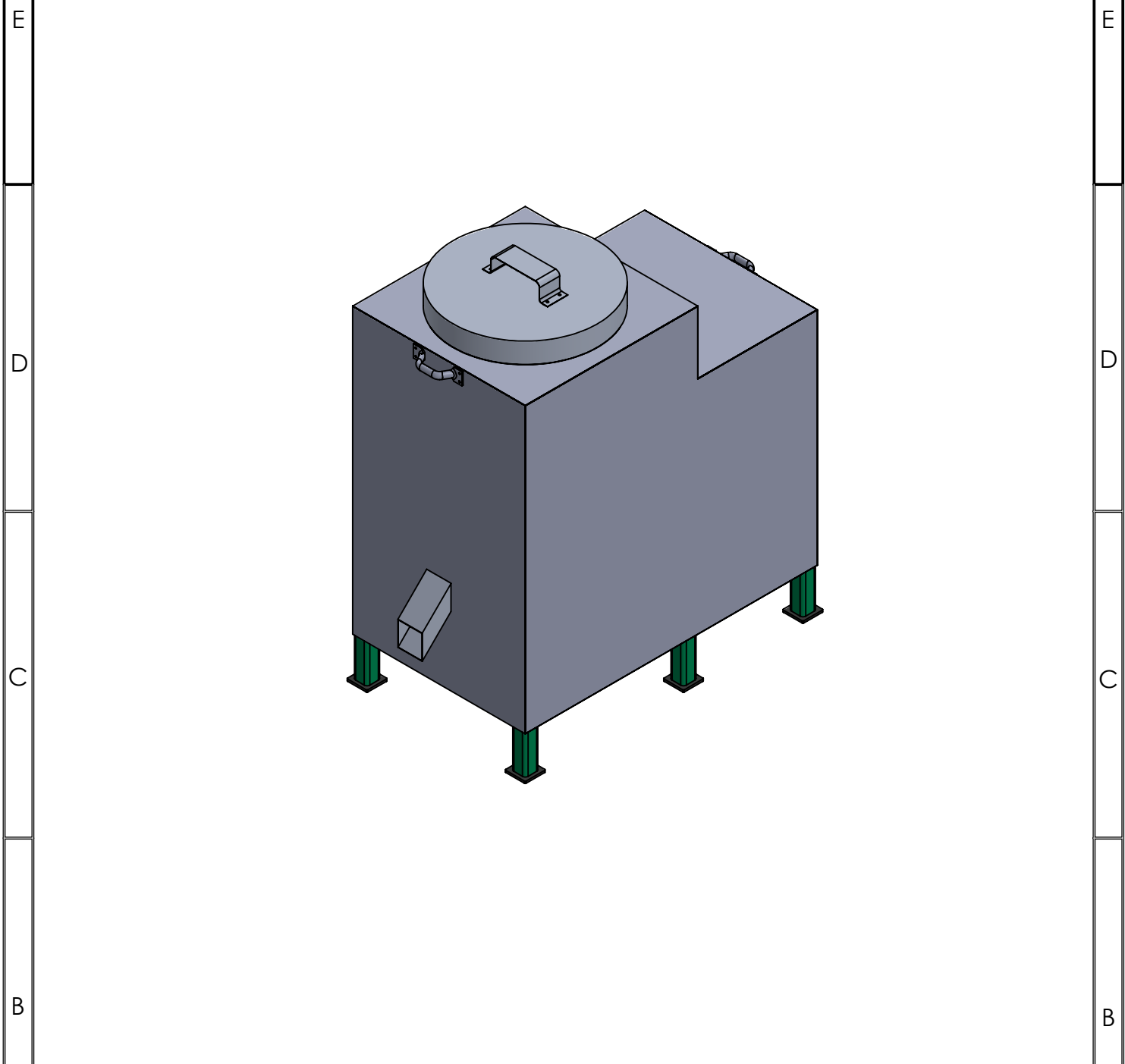

JML	NAMA BAGIAN					POS	BAHAN	UKURAN JADI	UKURAN KASAR	NO. ID	F
>	0	6	30	120	400	1000	PEKERJAAN LANJUT	NO ORDER		PROYEKSI	
<	6	30	120	400	1000	2000					
TOL	±0.1	±0.2	±0.3	±0.5	±0.8	±1.2					
NAMA								SKALA	DIGAMBAR	06/06/22	REYNALDI
MESIN PENYARING AMPAS TAHU								1 : 10	DIPERIKSA		HILAL
									DISAHKAN		
NO. ASSY :								FORMAT	SATUAN	MPAT/01	
POLITEKNIK NEGERI CILACAP, JURUSAN TEKNIK MESIN JL. dr. SOETOMO, NO : 01, SIDAKAYA, CILACAP, 53121 TELP. 0282 - 533329, E-mail : tmpnc@politeknikcilacap.ac.id								A4	mm		

5		4		3		2		1	
---	--	---	--	---	--	---	--	---	--

PERUBAHAN DARI :

DIGANTI DENGAN :

5		4		3		2		1	
NO	PERUBAHAN	TANGGAL	NAMA	NO	PERUBAHAN	TANGGAL	NAMA		
				△					

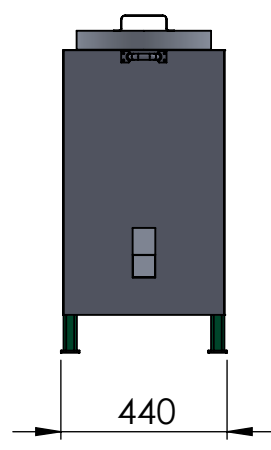
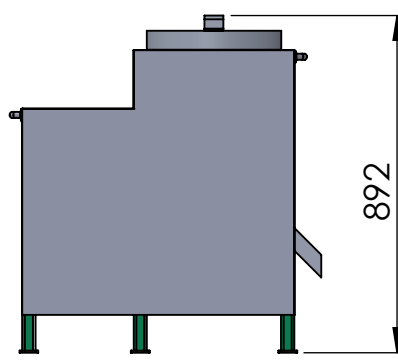
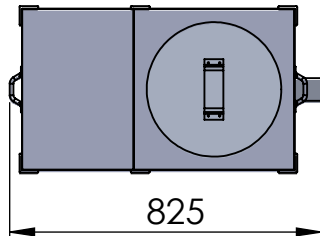

JML	NAMA BAGIAN					POS	BAHAN	UKURAN JADI	UKURAN KASAR	NO. ID	F
>	0	6	30	120	400	1000	PEKERJAAN LANJUT	NO ORDER	PROYEKSI		
<	6	30	120	400	1000	2000					
TOL	±0.1	±0.2	±0.3	±0.5	±0.8	±1.2					
NAMA								SKALA	DIGAMBAR	06/06/22	REYNALDI
MESIN PENYARING AMPAS TAHU								1 : 20	DIPERIKSA		HILAL
									DISAHKAN		
NO. ASSY :								FORMAT	SATUAN	MPAT/02	
POLITEKNIK NEGERI CILACAP, JURUSAN TEKNIK MESIN JL. dr. SOETOMO, NO : 01, SIDAKAYA, CILACAP, 53121 TELP. 0282 - 533329, E-mail : tmpnc@politeknikcilacap.ac.id								A4	mm		

5		4			3		2		1	
NO	PERUBAHAN	TANGGAL	NAMA	NO	PERUBAHAN	TANGGAL	NAMA			
				△						

1	RANGKA			LIHAT DETAIL		A	
1	TRANSMISI			LIHAT DETAIL		B	
1	TABUNG PUTAR			LIHAT DETAIL		C	
1	TABUNG PENAMPUNG			LIHAT DETAIL		D	

JML	NAMA BAGIAN						POS	BAHAN	UKURAN JADI	UKURAN KASAR	NO. ID	F	
>	0	6	30	120	400	1000	PEKERJAAN LANJUT			NO ORDER		PROYEKSI 	
<	6	30	120	400	1000	2000							
TOL	±0.1	±0.2	±0.3	±0.5	±0.8	±1.2							

NAMA				SKALA		DIGAMBAR		06/06/22		REYNALDI	
MESIN PENYARING AMPAS TAHU				1 : 10		DIPERIKSA				HILAL	
						DISAHKAN					
NO. ASSY :				FORMAT		SATUAN		MPAT/03			
POLITEKNIK NEGERI CILACAP, JURUSAN TEKNIK MESIN JL. dr. SOETOMO, NO : 01, SIDAKAYA, CILACAP, 53121 TELP. 0282 - 533329, E-mail : tmpnc@politeknikcilacap.ac.id				A4		mm					

5		4			3		2		1	
PERUBAHAN DARI :		DIGANTI DENGAN :								

5		4		3		2		1	
NO	PERUBAHAN	TANGGAL	NAMA	NO	PERUBAHAN	TANGGAL	NAMA		
				△					

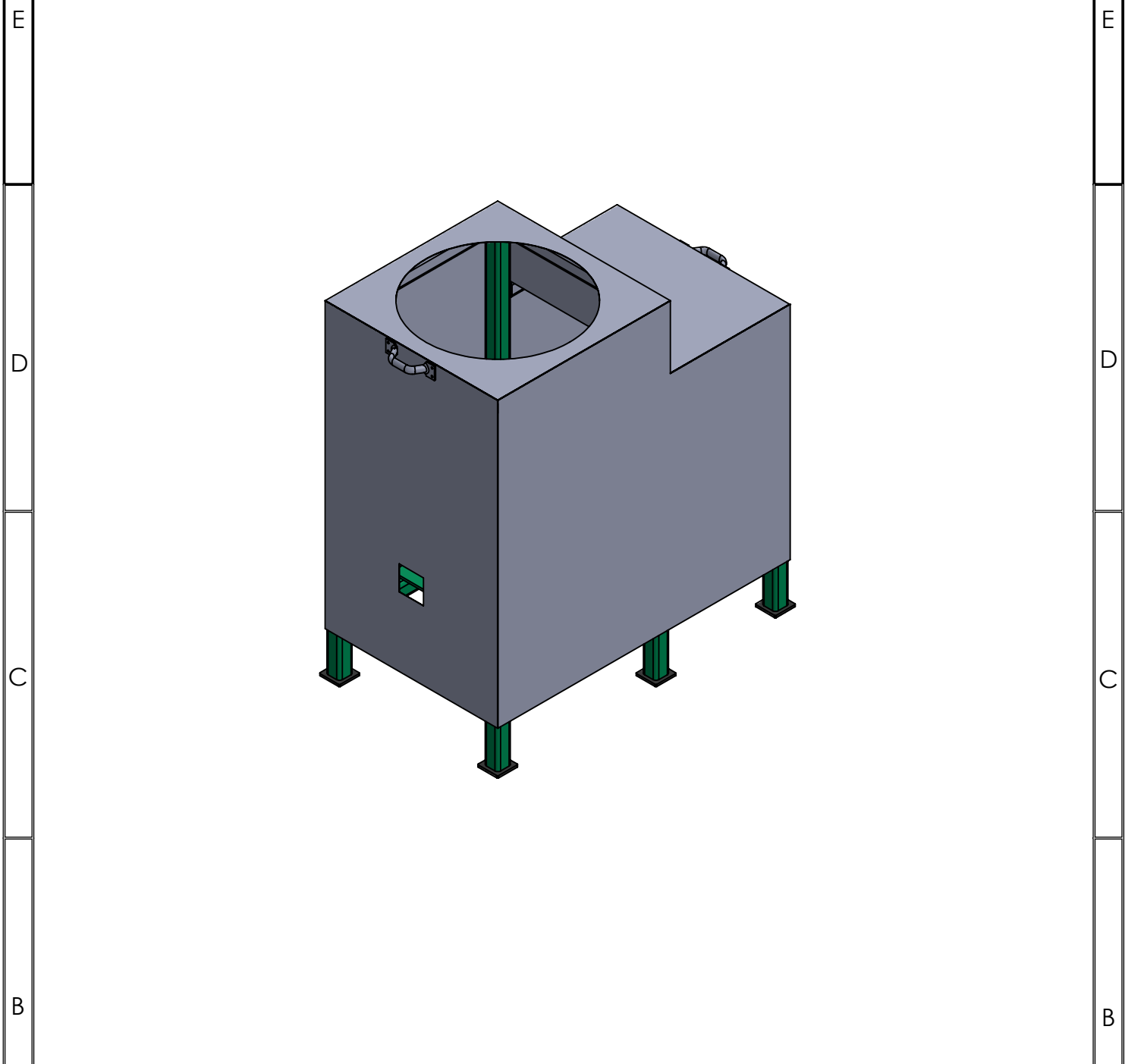

JML	NAMA BAGIAN					POS	BAHAN	UKURAN JADI	UKURAN KASAR	NO. ID	F
>	0	6	30	120	400	1000	PEKERJAAN LANJUT	NO ORDER		PROYEKSI	
<	6	30	120	400	1000	2000					
TOL	±0.1	±0.2	±0.3	±0.5	±0.8	±1.2					
NAMA								SKALA	DIGAMBAR	06/06/22	REYNALDI
SUB ASSEMBLY RANGKA								1 : 10	DIPERIKSA		HILAL
									DISAHKAN		
NO. ASSY :								FORMAT	SATUAN	MPAT/04	
POLITEKNIK NEGERI CILACAP, JURUSAN TEKNIK MESIN JL. dr. SOETOMO, NO : 01, SIDAKAYA, CILACAP, 53121 TELP. 0282 - 533329, E-mail : tmpnc@politeknikcilacap.ac.id								A4	mm		

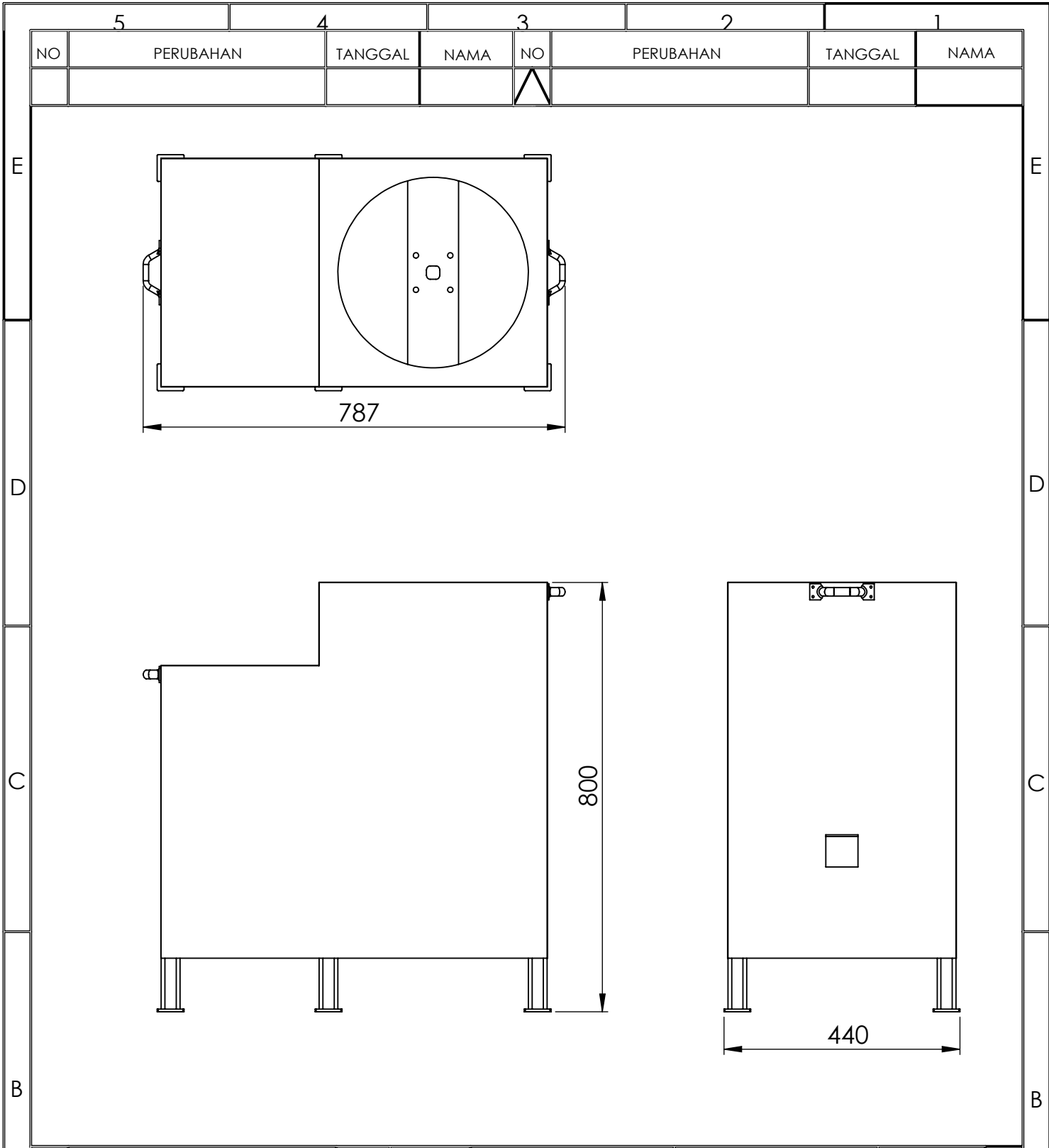

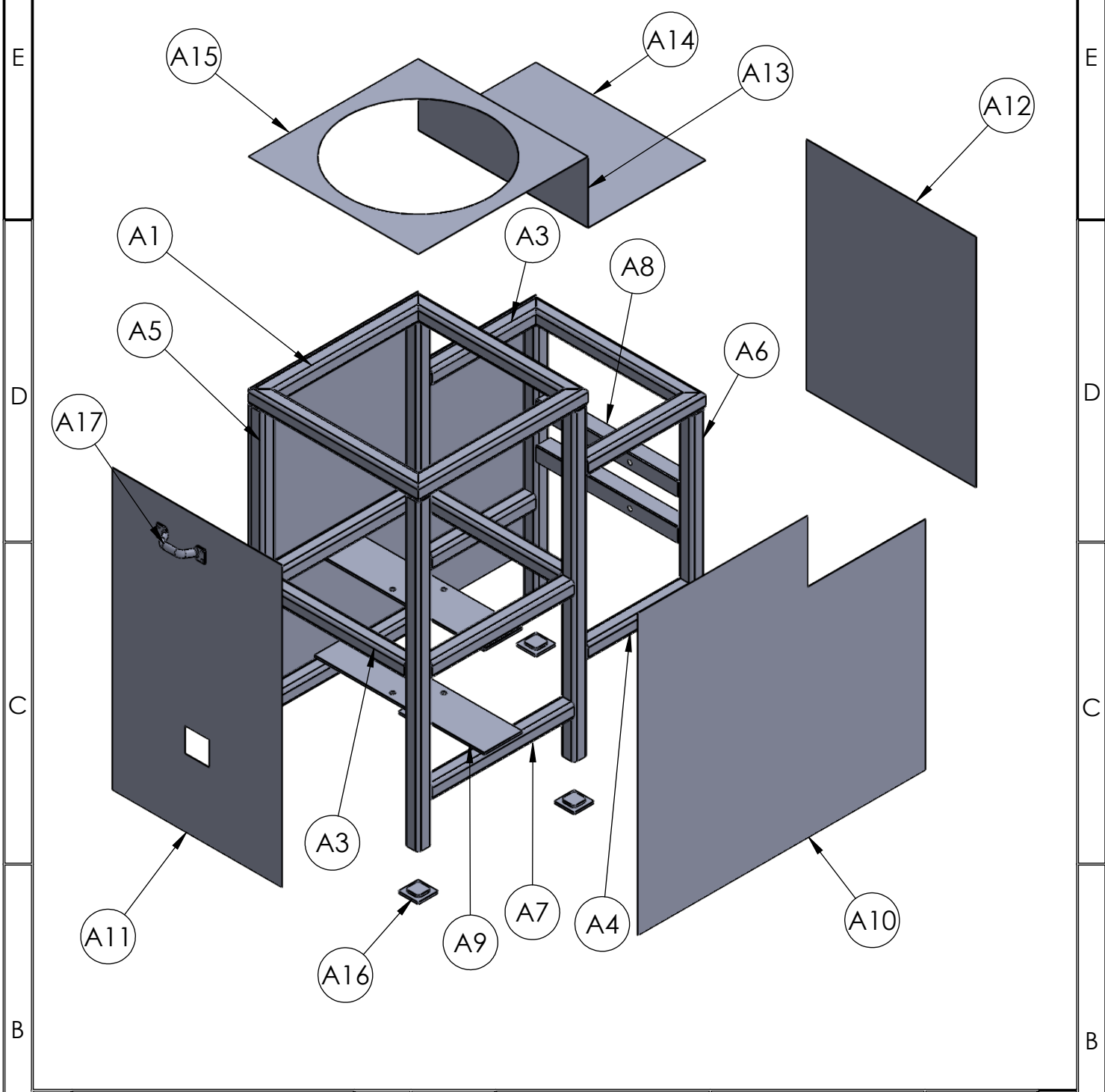

JML	NAMA BAGIAN						POS	BAHAN	UKURAN JADI	UKURAN KASAR	NO. ID	F
>	0	6	30	120	400	1000	PEKERJAAN LANJUT		NO ORDER	PROYEKSI		
<	6	30	120	400	1000	2000						
TOL	±0.1	±0.2	±0.3	±0.5	±0.8	±1.2						
NAMA <h3 style="text-align: center;">SUB ASSEMBLY RANGKA</h3>									SKALA 1 : 10	DIGAMBAR 06/06/22	REYNALDI	
NO. ASSY :									DISAHKAN	HILAL		
POLITEKNIK NEGERI CILACAP, JURUSAN TEKNIK MESIN JL. dr. SOETOMO, NO : 01, SIDAKAYA, CILACAP, 53121 TELP. 0282 - 533329, E-mail : tmpnc@politeknikcilacap.ac.id									FORMAT A4	SATUAN mm	MPAT/05	

5			4			3			2			1			
NO	PERUBAHAN			TANGGAL	NAMA			NO	PERUBAHAN			TANGGAL	NAMA		
								^							

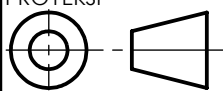

JML	NAMA BAGIAN						POS	BAHAN	UKURAN JADI	UKURAN KASAR	NO. ID	F
>	0	6	30	120	400	1000	PEKERJAAN LANJUT		NO ORDER	PROYEKSI		
<	6	30	120	400	1000	2000						
TOL	±0.1	±0.2	±0.3	±0.5	±0.8	±1.2						

NAMA <h2 style="text-align: center;">SUB ASSEMBLY RANGKA</h2>								SKALA 1 : 10	DIGAMBAR	06/06/22	REYNALDI
NO. ASSY :									DIPERIKSA		HILAL
									DISAHKAN		
POLITEKNIK NEGERI CILACAP, JURUSAN TEKNIK MESIN JL. dr. SOETOMO, NO : 01, SIDAKAYA, CILACAP, 53121 TELP. 0282 - 533329, E-mail : tmpnc@politeknikcilacap.ac.id								FORMAT A4	SATUAN mm	MPAT/06	

5		4		3		2		1		
NO	PERUBAHAN	TANGGAL	NAMA	NO	PERUBAHAN	TANGGAL	NAMA			
E										
5	RANGKA ATAS 1		MILDSTEEL				A1			
2	RANGKA ATAS 2		MILDSTEEL	LIHAT DETAIL			A2			
4	RANGKA TENGAH 1		MILDSTEEL	LIHAT DETAIL			A3			
2	RANGKA TENGAH 2		MILDSTEEL	LIHAT DETAIL			A4			
4	RANGKA KAKI 1		MILDSTEEL	LIHAT DETAIL			A5			
2	RANGKA KAKI 2		MILDSTEEL	LIHAT DETAIL			A6			
2	RANGKA DUDUKAN MOTOR		MILDSTEEL	LIHAT DETAIL			A7			
2	RANGKA BAWAH		MILDSTEEL	LIHAT DETAIL			A8			
2	RANGKA DUDUKAN BEARING		MILDSTEEL	LIHAT DETAIL			A9			
2	COVER 1		GALVALUM	LIHAT DETAIL			A10			
1	COVER 2		GALVALUM	LIHAT DETAIL			A11			
1	COVER 3		GALVALUM	LIHAT DETAIL			A12			
1	COVER 4		GALVALUM	LIHAT DETAIL			A13			
1	COVER 5		GALVALUM	LIHAT DETAIL			A14			
1	COVER 6		GALVALUM	LIHAT DETAIL			A15			
6	KAKI		RUBBER	LIHAT DETAIL			A16			
2	GAGANG		MILDSTEEL	LIHAT DETAIL			A17			
JML	NAMA BAGIAN	POS	BAHAN	UKURAN JADI	UKURAN KASAR	NO. ID	F			
>	0	6	30	120	400	1000	PEKERJAAN LANJUT		NO ORDER	
<	6	30	120	400	1000	2000	PROYEKSI			
TOL	±0.1	±0.2	±0.3	±0.5	±0.8	±1.2				
NAMA					SKALA	DIGAMBAR	06/06/22	REYNALDI		
SUB ASSEMBLY RANGKA					1 : 10	DIPERIKSA		HILAL		
						DISAHKAN				
NO. ASSY :					FORMAT	SATUAN	MPAT/07			
 POLITEKNIK NEGERI CILACAP, JURUSAN TEKNIK MESIN JL. dr. SOETOMO, NO : 01, SIDAKAYA, CILACAP, 53121 Telp. 0282 - 533329, E-mail : tmpnc@politeknikcilacap.ac.id					A4	mm				
5		4		3		2		1		

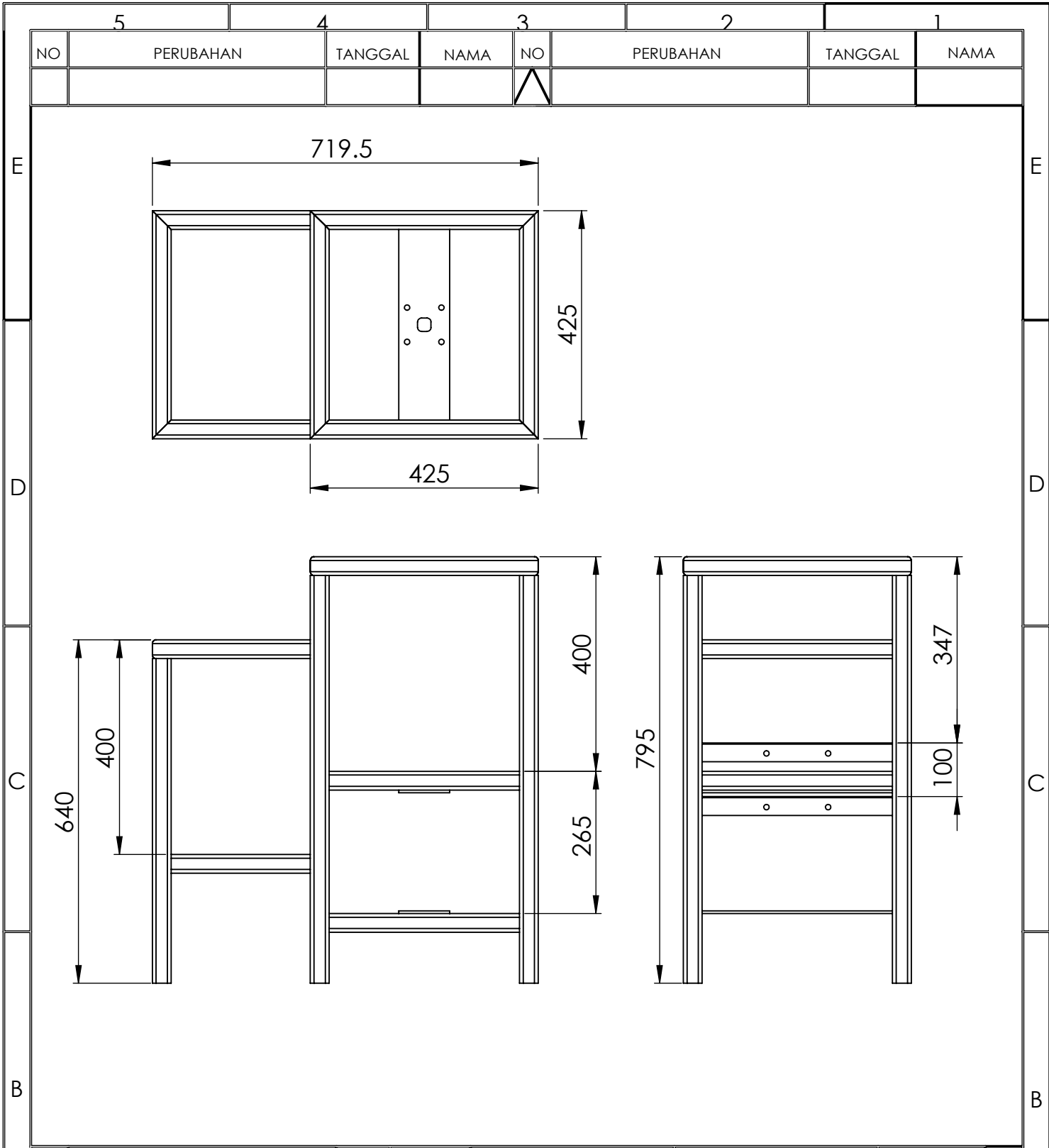

JML	NAMA BAGIAN					POS	BAHAN	UKURAN JADI	UKURAN KASAR	NO. ID	F
>	0	6	30	120	400	1000	PEKERJAAN LANJUT	NO ORDER		REYNALDI	A
<	6	30	120	400	1000	2000					
TOL	±0.1	±0.2	±0.3	±0.5	±0.8	±1.2					
NAMA SUB ASSEMBLY RANGKA								SKALA 1 : 10	DIGAMBAR 06/06/22	REYNALDI	A
NO. ASSY :								DISAHKAN	HILAL		
POLITEKNIK NEGERI CILACAP, JURUSAN TEKNIK MESIN JL. dr. SOETOMO, NO : 01, SIDAKAYA, CILACAP, 53121 Telp. 0282 - 533329, E-mail : tmpnc@politeknikcilacap.ac.id								FORMAT A4	SATUAN mm	MPAT/08	A

PERUBAHAN DARI :

DIGANTI DENGAN :

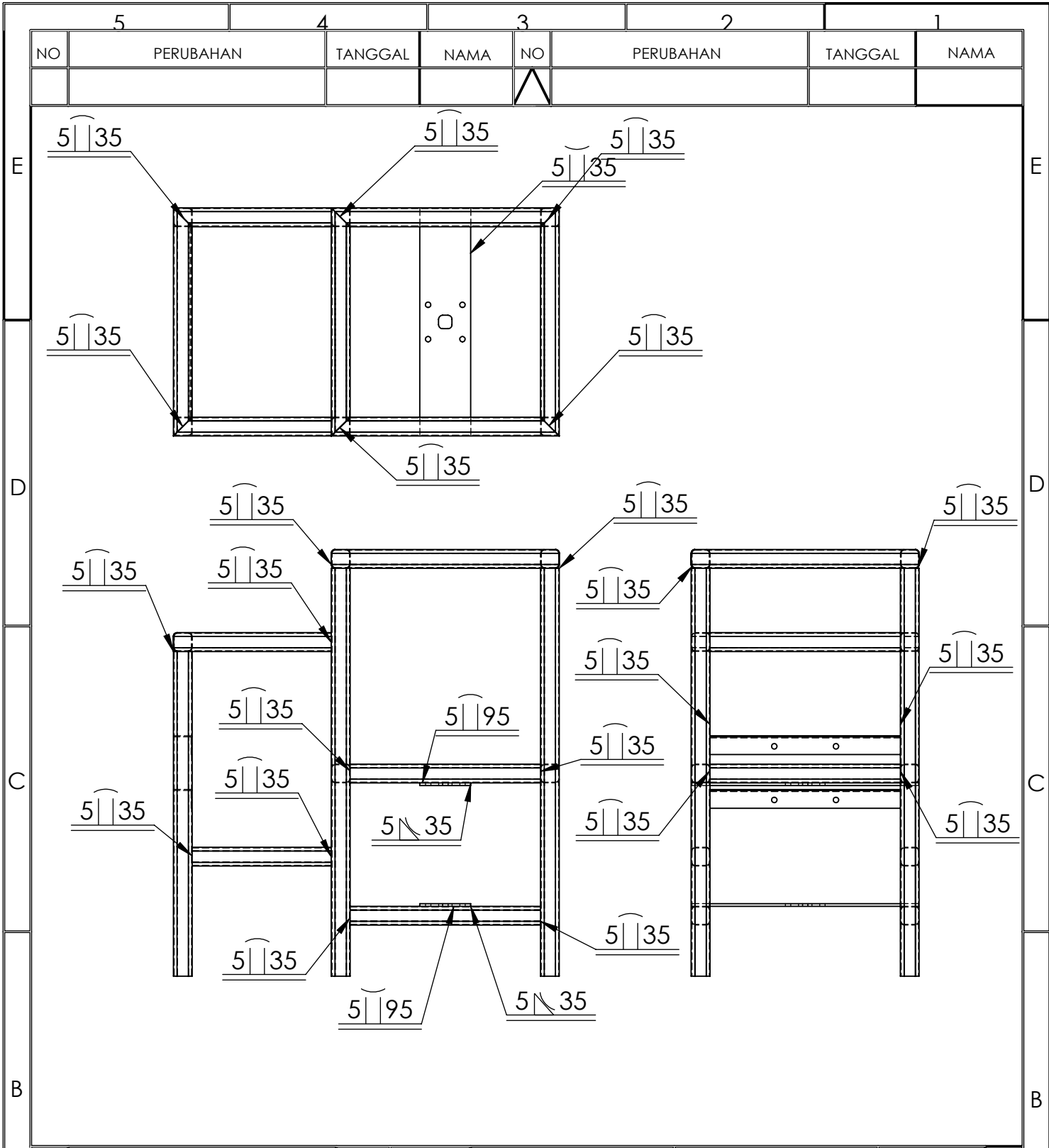

JML	NAMA BAGIAN						POS	BAHAN	UKURAN JADI	UKURAN KASAR	NO. ID	F
>	0	6	30	120	400	1000	PEKERJAAN LANJUT		NO ORDER	PROYEKSI 		
<	6	30	120	400	1000	2000						
TOL	±0.1	±0.2	±0.3	±0.5	±0.8	±1.2						

NAMA SUB ASSEMBLY RANGKA NO. ASSY :	SKALA 1 : 10	DIGAMBAR	06/06/22	REYNALDI
		DIPERIKSA		HILAL
		DISAHKAN		
POLITEKNIK NEGERI CILACAP, JURUSAN TEKNIK MESIN Jl. dr. SOETOMO, NO : 01, SIDAKAYA, CILACAP, 53121 TELP. 0282 - 533329, E-mail : tmpnc@politeknikcilacap.ac.id	FORMAT A4	SATUAN mm	MPAT/09	

PERUBAHAN DARI : DIGANTI DENGAN :



5		4			3		2		1	
NO	PERUBAHAN	TANGGAL	NAMA	NO	PERUBAHAN	TANGGAL	NAMA			
				/						

JML	NAMA BAGIAN					POS	BAHAN	UKURAN JADI	UKURAN KASAR	NO. ID	F
>	0	6	30	120	400	1000	PEKERJAAN LANJUT	NO ORDER			
<	6	30	120	400	1000	2000					
TOL	±0.1	±0.2	±0.3	±0.5	±0.8	±1.2					

NAMA <h2 style="text-align: center;">RANGKA ATAS 1</h2>	SKALA <h3 style="text-align: center;">1 : 5</h3>	DIGAMBAR 06/06/22 DIPERIKSA DISAHKAN 	REYNALDI HILAL
NO. ASSY :	FORMAT A4	SATUAN mm	MPAT/10

5		4			3		2		1	
---	--	---	--	--	---	--	---	--	---	--

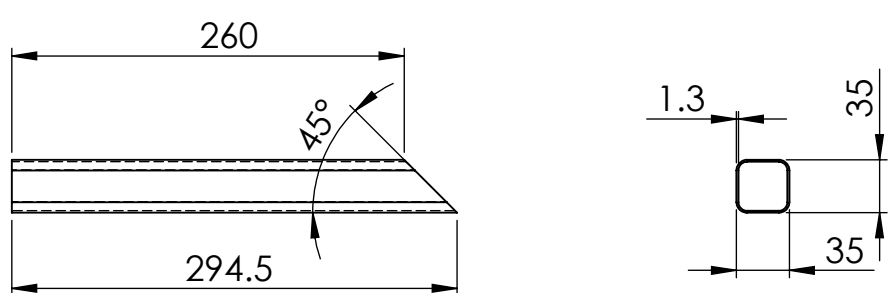
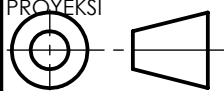
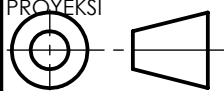
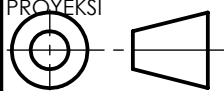
PERUBAHAN DARI : DIGANTI DENGAN :

5		4			3		2			1																																							
NO	PERUBAHAN	TANGGAL	NAMA	NO	PERUBAHAN	TANGGAL	NAMA																																										
				/																																													
<div style="display: flex; justify-content: space-around; align-items: center;">  </div>																																																	
<table border="1" style="width:100%; border-collapse: collapse;"> <tr> <td style="width: 5%;">JML</td> <td colspan="5" style="width: 40%;">NAMA BAGIAN</td> <td style="width: 5%;">POS</td> <td style="width: 10%;">BAHAN</td> <td style="width: 15%;">UKURAN JADI</td> <td style="width: 15%;">UKURAN KASAR</td> <td style="width: 10%;">NO. ID</td> <td style="width: 5%;">F</td> </tr> <tr> <td style="text-align: center;">></td> <td style="text-align: center;">0</td> <td style="text-align: center;">6</td> <td style="text-align: center;">30</td> <td style="text-align: center;">120</td> <td style="text-align: center;">400</td> <td style="text-align: center;">1000</td> <td colspan="2" rowspan="3" style="text-align: center;">PEKERJAAN LANJUT</td> <td colspan="2" rowspan="3" style="text-align: center;">NO ORDER</td> <td rowspan="3" style="text-align: center;">  </td> </tr> <tr> <td style="text-align: center;"><</td> <td style="text-align: center;">6</td> <td style="text-align: center;">30</td> <td style="text-align: center;">120</td> <td style="text-align: center;">400</td> <td style="text-align: center;">1000</td> <td style="text-align: center;">2000</td> </tr> <tr> <td style="text-align: center;">TOL</td> <td style="text-align: center;">±0.1</td> <td style="text-align: center;">±0.2</td> <td style="text-align: center;">±0.3</td> <td style="text-align: center;">±0.5</td> <td style="text-align: center;">±0.8</td> <td style="text-align: center;">±1.2</td> </tr> </table>												JML	NAMA BAGIAN					POS	BAHAN	UKURAN JADI	UKURAN KASAR	NO. ID	F	>	0	6	30	120	400	1000	PEKERJAAN LANJUT		NO ORDER			<	6	30	120	400	1000	2000	TOL	±0.1	±0.2	±0.3	±0.5	±0.8	±1.2
JML	NAMA BAGIAN					POS	BAHAN	UKURAN JADI	UKURAN KASAR	NO. ID	F																																						
>	0	6	30	120	400	1000	PEKERJAAN LANJUT		NO ORDER																																								
<	6	30	120	400	1000	2000																																											
TOL	±0.1	±0.2	±0.3	±0.5	±0.8	±1.2																																											
<p>NAMA</p> <h2 style="margin: 0;">RANGKA ATAS 2</h2> <p>NO. ASSY :</p>								<p>SKALA</p> <h2 style="margin: 0;">1 : 5</h2>		<p>DIGAMBAR</p> <p>06/06/22</p> <p>REYNALDI</p>		<p>DIPERIKSA</p> <p>HILAL</p>		<p>DISAHKAN</p>																																			
 <p>POLITEKNIK NEGERI CILACAP, JURUSAN TEKNIK MESIN</p> <p>JL. dr. SOETOMO, NO : 01, SIDAKAYA, CILACAP, 53121</p> <p>TELP. 0282 - 533329, E-mail : tmpnc@politeknikcilacap.ac.id</p>								<p>FORMAT</p> <h2 style="margin: 0;">A4</h2>		<p>SATUAN</p> <p>mm</p>		<h2 style="margin: 0;">MPAT/11</h2>																																					

5		4			3		2		1	
NO	PERUBAHAN			TANGGAL	NAMA	NO	PERUBAHAN		TANGGAL	NAMA
						△				

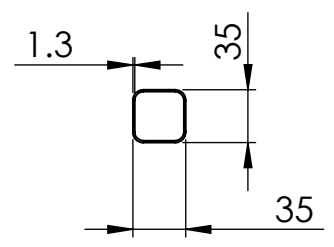
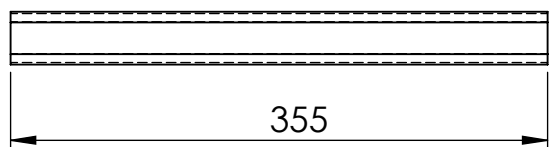

JML	NAMA BAGIAN					POS	BAHAN	UKURAN JADI	UKURAN KASAR	NO. ID	F
>	0	6	30	120	400	1000	PEKERJAAN LANJUT	NO ORDER			
<	6	30	120	400	1000	2000					
TOL	±0.1	±0.2	±0.3	±0.5	±0.8	±1.2					
NAMA								SKALA	DIGAMBAR	06/06/22	REYNALDI
RANGKA TENGAH 1								1 : 5	DIPERIKSA		HILAL
									DISAHKAN		
NO. ASSY :								FORMAT	SATUAN	MPAT/12	
POLITEKNIK NEGERI CILACAP, JURUSAN TEKNIK MESIN JL. dr. SOETOMO, NO : 01, SIDAKAYA, CILACAP, 53121 TELP. 0282 - 533329, E-mail : tmpnc@politeknikcilacap.ac.id								A4	mm		

5		4			3		2		1																																									
NO	PERUBAHAN			TANGGAL	NAMA	NO	PERUBAHAN		TANGGAL	NAMA																																								
						△																																												
<table border="1"> <thead> <tr> <th>JML</th> <th colspan="6">NAMA BAGIAN</th> <th>POS</th> <th>BAHAN</th> <th>UKURAN JADI</th> <th>UKURAN KASAR</th> <th>NO. ID</th> <th>F</th> </tr> </thead> <tbody> <tr> <td>></td> <td>0</td> <td>6</td> <td>30</td> <td>120</td> <td>400</td> <td>1000</td> <td rowspan="3">PEKERJAAN LANJUT</td> <td rowspan="3"></td> <td rowspan="3">NO ORDER</td> <td rowspan="3"> </td> <td rowspan="3"></td> <td rowspan="3"></td> </tr> <tr> <td><</td> <td>6</td> <td>30</td> <td>120</td> <td>400</td> <td>1000</td> <td>2000</td> </tr> <tr> <td>TOL</td> <td>±0.1</td> <td>±0.2</td> <td>±0.3</td> <td>±0.5</td> <td>±0.8</td> <td>±1.2</td> </tr> </tbody> </table>											JML	NAMA BAGIAN						POS	BAHAN	UKURAN JADI	UKURAN KASAR	NO. ID	F	>	0	6	30	120	400	1000	PEKERJAAN LANJUT		NO ORDER				<	6	30	120	400	1000	2000	TOL	±0.1	±0.2	±0.3	±0.5	±0.8	±1.2
JML	NAMA BAGIAN						POS	BAHAN	UKURAN JADI	UKURAN KASAR	NO. ID	F																																						
>	0	6	30	120	400	1000	PEKERJAAN LANJUT		NO ORDER																																									
<	6	30	120	400	1000	2000																																												
TOL	±0.1	±0.2	±0.3	±0.5	±0.8	±1.2																																												
NAMA RANGKA TENGAH 2									SKALA 1 : 5	DIGAMBAR 06/06/22 DIPERIKSA DISAHKAN	REYNALDI HILAL																																							
NO. ASSY :									FORMAT A4	SATUAN mm	MPAT/13																																							
5		4			3		2		1																																									

	5		4		3		2		1
NO	PERUBAHAN	TANGGAL	NAMA	NO	PERUBAHAN	TANGGAL	NAMA	NO	PERUBAHAN
				/					

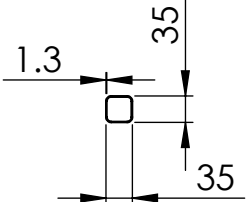
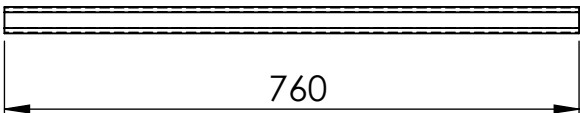

JML	NAMA BAGIAN					POS	BAHAN	UKURAN JADI	UKURAN KASAR	NO. ID	F
>	0	6	30	120	400	1000	PEKERJAAN LANJUT	NO ORDER			
<	6	30	120	400	1000	2000					
TOL	±0.1	±0.2	±0.3	±0.5	±0.8	±1.2					
NAMA								SKALA	DIGAMBAR	06/06/22	REYNALDI
RANGKA KAKI 1								1 : 10	DIPERIKSA	HILAL	
NO. ASSY :								DISAHKAN			
POLITEKNIK NEGERI CILACAP, JURUSAN TEKNIK MESIN JL. dr. SOETOMO, NO : 01, SIDAKAYA, CILACAP, 53121 TELP. 0282 - 533329, E-mail : tmpnc@politeknikcilacap.ac.id								FORMAT	SATUAN	MPAT/14	
A4								mm			

5		4			3		2		1		
NO	PERUBAHAN	TANGGAL	NAMA	NO	PERUBAHAN	TANGGAL	NAMA				
				/							
E											E
D											D
C											C
B											B
A											A

JML	NAMA BAGIAN					POS	BAHAN	UKURAN JADI	UKURAN KASAR	NO. ID	F
>	0	6	30	120	400	1000	PEKERJAAN LANJUT	NO ORDER			
<	6	30	120	400	1000	2000					
TOL	±0.1	±0.2	±0.3	±0.5	±0.8	±1.2					
NAMA								SKALA	DIGAMBAR	06/06/22	REYNALDI
RANGKA KAKI 2								1 : 10	DIPERIKSA	HILAL	
NO. ASSY :								DISAHKAN			
POLITEKNIK NEGERI CILACAP, JURUSAN TEKNIK MESIN JL. dr. SOETOMO, NO : 01, SIDAKAYA, CILACAP, 53121 TELP. 0282 - 533329, E-mail : tmpnc@politeknikcilacap.ac.id								FORMAT	SATUAN	MPAT/15	
								A4	mm		
5		4			3		2		1		

PERUBAHAN DARI :
DIGANTI DENGAN :

5		4			3		2		1	
NO	PERUBAHAN			TANGGAL	NAMA	NO	PERUBAHAN		TANGGAL	NAMA
						△				

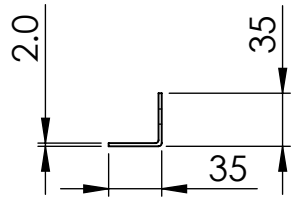
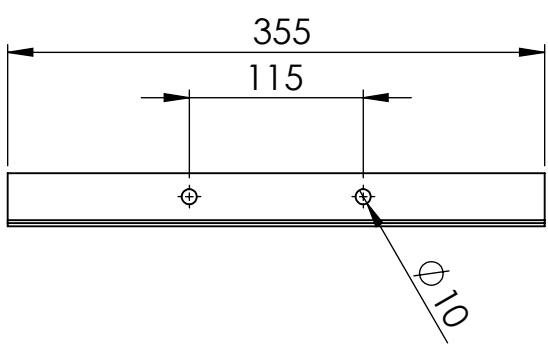

JML	NAMA BAGIAN					POS	BAHAN	UKURAN JADI	UKURAN KASAR	NO. ID	F
>	0	6	30	120	400	1000	PEKERJAAN LANJUT	NO ORDER	PROYEKSI		
<	6	30	120	400	1000	2000					
TOL	±0.1	±0.2	±0.3	±0.5	±0.8	±1.2					
NAMA								SKALA	DIGAMBAR	06/06/22	REYNALDI
RANGKA DUDUKAN MOTOR								1 : 5	DIPERIKSA		HILAL
									DISAHKAN		
NO. ASSY :								FORMAT	SATUAN	MPAT/16	
POLITEKNIK NEGERI CILACAP, JURUSAN TEKNIK MESIN JL. dr. SOETOMO, NO : 01, SIDAKAYA, CILACAP, 53121 TELP. 0282 - 533329, E-mail : tmpnc@politeknikcilacap.ac.id								A4	mm		

PERUBAHAN DARI :

DIGANTI DENGAN :

5		4			3		2			1	
NO	PERUBAHAN			TANGGAL	NAMA	NO	PERUBAHAN			TANGGAL	NAMA

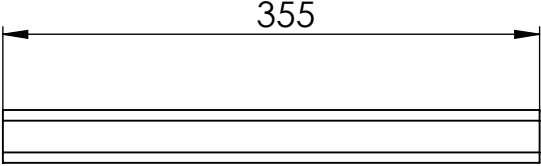

355

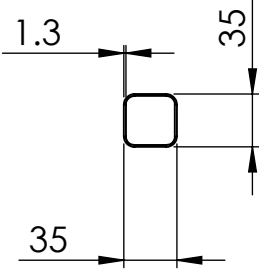

1.3
35
35

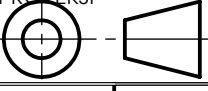
JML	NAMA BAGIAN					POS	BAHAN	UKURAN JADI	UKURAN KASAR	NO. ID	F
>	0	6	30	120	400	1000	PEKERJAAN LANJUT	NO ORDER			
<	6	30	120	400	1000	2000					
TOL	±0.1	±0.2	±0.3	±0.5	±0.8	±1.2					

NAMA RANGKA BAWAH				SKALA 1 : 5	DIGAMBAR 06/06/22 DIPERIKSA DISAHKAN	REYNALDI HILAL
NO. ASSY :				FORMAT A4	SATUAN mm	MPAT/16

5		4			3		2			1	
---	--	---	--	--	---	--	---	--	--	---	--

	5		4		3		2		1
NO	PERUBAHAN	TANGGAL	NAMA	NO	PERUBAHAN	TANGGAL	NAMA	NO	PERUBAHAN
				/					

JML	NAMA BAGIAN						POS	BAHAN	UKURAN JADI	UKURAN KASAR	NO. ID	F
>	0	6	30	120	400	1000	PEKERJAAN LANJUT	NO ORDER				
<	6	30	120	400	1000	2000						
TOL	±0.1	±0.2	±0.3	±0.5	±0.8	±1.2						

NAMA <h2 style="text-align:center;">RANGKA DUDUKAN BEARING</h2>	SKALA <h3 style="text-align:center;">1 : 5</h3>	DIGAMBAR 06/06/22 DIPERIKSA DISAHKAN 	REYNALDI HILAL
NO. ASSY : POLITEKNIK NEGERI CILACAP, JURUSAN TEKNIK MESIN JL. dr. SOETOMO, NO : 01, SIDAKAYA, CILACAP, 53121 TELP. 0282 - 533329, E-mail : tmpnc@politeknikcilacap.ac.id	FORMAT <h3 style="text-align:center;">A4</h3>	SATUAN mm	<h2 style="font-size: 2em;">MPAT/18</h2>

5		4		3		2		1	
NO	PERUBAHAN	TANGGAL	NAMA	NO	PERUBAHAN	TANGGAL	NAMA		
				△					

JML	NAMA BAGIAN					POS	BAHAN	UKURAN JADI	UKURAN KASAR	NO. ID	F
>	0	6	30	120	400	1000	PEKERJAAN LANJUT	NO ORDER			
<	6	30	120	400	1000	2000					
TOL	±0.1	±0.2	±0.3	±0.5	±0.8	±1.2					
NAMA								SKALA	DIGAMBAR	06/06/22	REYNALDI
COVER 1								1 : 10	DIPERIKSA		HILAL
									DISAHKAN		
NO. ASSY :								FORMAT	SATUAN	MPAT/19	
POLITEKNIK NEGERI CILACAP, JURUSAN TEKNIK MESIN JL. dr. SOETOMO, NO : 01, SIDAKAYA, CILACAP, 53121 TELP. 0282 - 533329, E-mail : tmpnc@politeknikcilacap.ac.id								A4	mm		

PERUBAHAN DARI :

DIGANTI DENGAN :

5		4			3		2		1	
NO	PERUBAHAN	TANGGAL	NAMA	NO	PERUBAHAN	TANGGAL	NAMA			
				^						

E
E

D
D



C
C

B
B

A
A

JML	NAMA BAGIAN					POS	BAHAN	UKURAN JADI	UKURAN KASAR	NO. ID	F
>	0	6	30	120	400	1000	PEKERJAAN LANJUT	NO ORDER			
<	6	30	120	400	1000	2000					
TOL	±0.1	±0.2	±0.3	±0.5	±0.8	±1.2					
NAMA COVER 2								SKALA 1 : 5	DIGAMBAR 06/06/22	REYNALDI	
								DIPERIKSA		HILAL	
								DISAHKAN			
NO. ASSY :								FORMAT A4	SATUAN mm	MPAT/20	

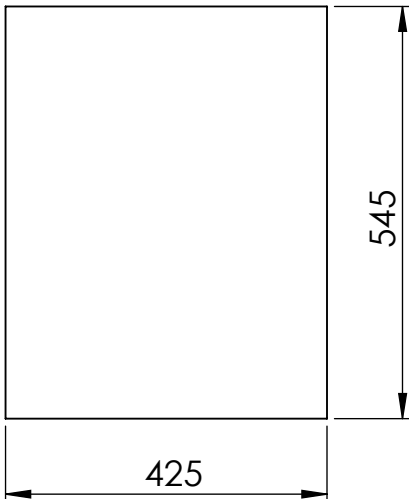
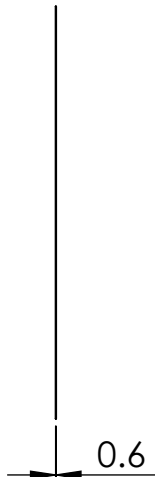
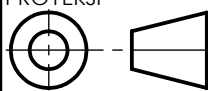
5		4			3		2		1	
PERUBAHAN DARI :		DIGANTI DENGAN :								

5		4			3		2		1			
NO	PERUBAHAN	TANGGAL	NAMA	NO	PERUBAHAN	TANGGAL	NAMA					
				^								
E	<div style="display: flex; justify-content: space-around; align-items: center;"> <div style="text-align: center;">  <p>425</p> <p>545</p> </div> <div style="text-align: center;">  <p>0.6</p> </div> </div>										E	
D											D	
C											C	
B											B	
JML		NAMA BAGIAN					POS	BAHAN	UKURAN JADI	UKURAN KASAR	NO. ID	F
>	0	6	30	120	400	1000	PEKERJAAN LANJUT		NO ORDER	PROYEKSI 		
<	6	30	120	400	1000	2000						
TOL	±0.1	±0.2	±0.3	±0.5	±0.8	±1.2						
NAMA								SKALA	DIGAMBAR	06/06/22	REYNALDI	
COVER 3								1 : 5	DIPERIKSA		HILAL	
									DISAHKAN			
NO. ASSY :								FORMAT	SATUAN	MPAT/21		
 POLITEKNIK NEGERI CILACAP, JURUSAN TEKNIK MESIN JL. dr. SOETOMO, NO : 01, SIDAKAYA, CILACAP, 53121 TELP. 0282 - 533329, E-mail : tmpnc@politeknikcilacap.ac.id								A4	mm			
5		4			3		2		1			

5		4			3		2			1	
NO	PERUBAHAN			TANGGAL	NAMA	NO	PERUBAHAN			TANGGAL	NAMA

JML	NAMA BAGIAN					POS	BAHAN	UKURAN JADI	UKURAN KASAR	NO. ID	F
>	0	6	30	120	400	1000	PEKERJAAN LANJUT	NO ORDER			
<	6	30	120	400	1000	2000					
TOL	±0.1	±0.2	±0.3	±0.5	±0.8	±1.2					

NAMA COVER 4	SKALA 1 : 5	DIGAMBAR 06/06/22 DIPERIKSA DISAHKAN	REYNALDI HILAL	A
----------------------------	--------------------	---	-------------------	---

NO. ASSY : POLITEKNIK NEGERI CILACAP, JURUSAN TEKNIK MESIN JL. dr. SOETOMO, NO : 01, SIDAKAYA, CILACAP, 53121 TELP. 0282 - 533329, E-mail : tmpnc@politeknikcilacap.ac.id	FORMAT A4	SATUAN mm	MPAT/22
---	------------------	------------------	----------------

5		4			3		2			1	
---	--	---	--	--	---	--	---	--	--	---	--

PERUBAHAN DARI :

DIGANTI DENGAN :

5		4			3		2		1			
NO	PERUBAHAN	TANGGAL	NAMA	NO	PERUBAHAN	TANGGAL	NAMA					
				△								
E											E	
D											D	
C											C	
B											B	
JML	NAMA BAGIAN					POS	BAHAN	UKURAN JADI	UKURAN KASAR	NO. ID	F	
>	0	6	30	120	400	1000	PEKERJAAN LANJUT		NO ORDER		PROYEKSI 	
<	6	30	120	400	1000	2000						
TOL	±0.1	±0.2	±0.3	±0.5	±0.8	±1.2						
NAMA								SKALA	DIGAMBAR	06/06/22	REYNALDI	
COVER 5								1 : 5	DIPERIKSA		HILAL	
NO. ASSY :								DISAHKAN				
POLITEKNIK NEGERI CILACAP, JURUSAN TEKNIK MESIN JL. dr. SOETOMO, NO : 01, SIDAKAYA, CILACAP, 53121 TELP. 0282 - 533329, E-mail : tmpnc@politeknikcilacap.ac.id								FORMAT	SATUAN		MPAT/23	
								A4	mm			
5		4			3		2		1			

PERUBAHAN DARI :

DIGANTI DENGAN :

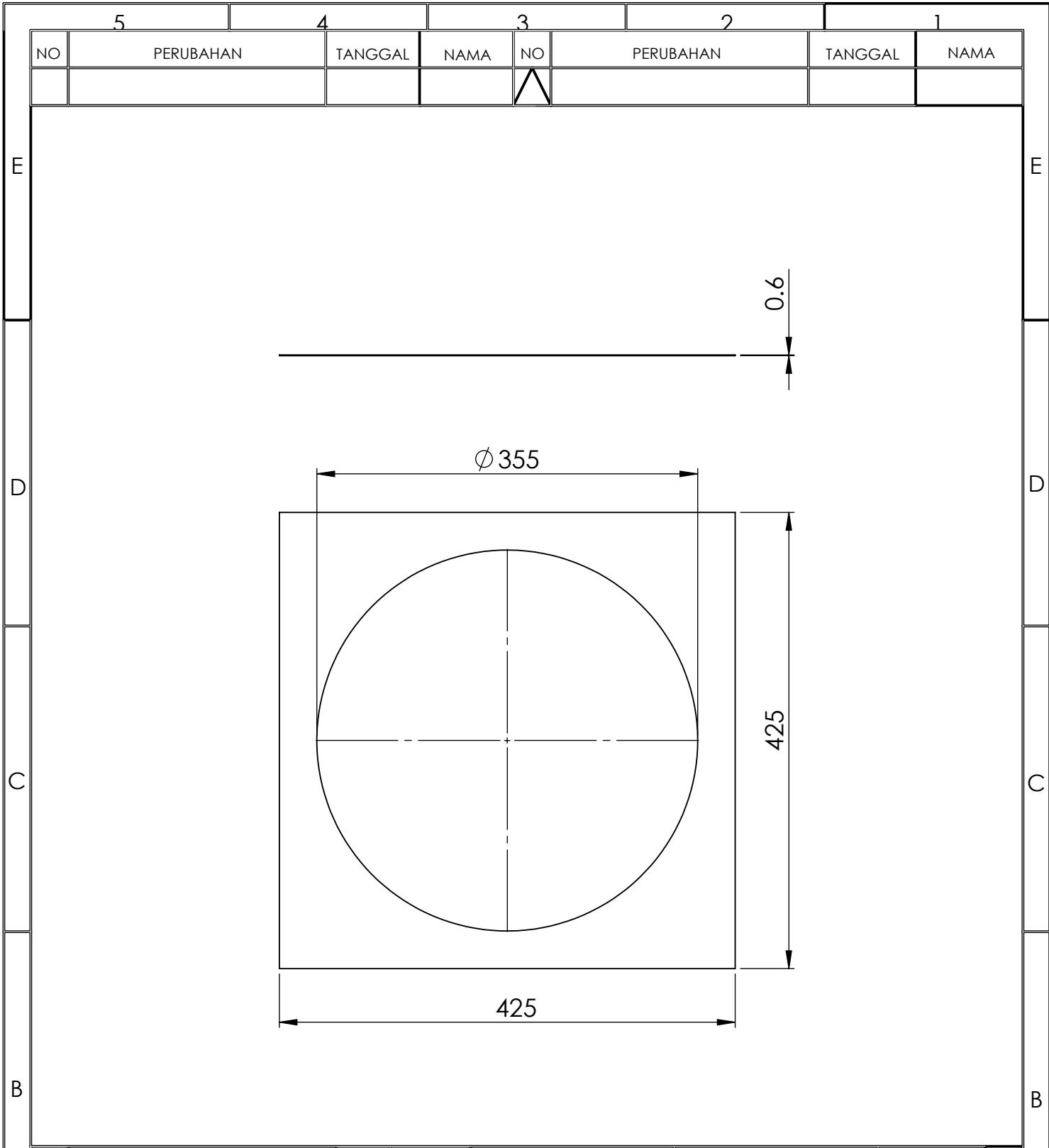

JML	NAMA BAGIAN						POS	BAHAN	UKURAN JADI	UKURAN KASAR	NO. ID	F
>	0	6	30	120	400	1000	PEKERJAAN LANJUT		NO ORDER			
<	6	30	120	400	1000	2000						
TOL	±0.1	±0.2	±0.3	±0.5	±0.8	±1.2						
NAMA COVER 6									SKALA 1 : 10	DIGAMBAR 06/06/22	REYNALDI	
NO. ASSY :										DIPERIKSA		HILAL
										DISAHKAN		
POLITEKNIK NEGERI CILACAP, JURUSAN TEKNIK MESIN JL. dr. SOETOMO, NO : 01, SIDAKAYA, CILACAP, 53121 TELP. 0282 - 533329, E-mail : tmpnc@politeknikcilacap.ac.id									FORMAT A4	SATUAN mm	MPAT/24	

PERUBAHAN DARI :

DIGANTI DENGAN :

5		4		3		2		1	
NO	PERUBAHAN	TANGGAL	NAMA	NO	PERUBAHAN	TANGGAL	NAMA		
				△					

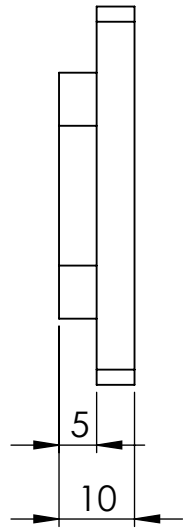
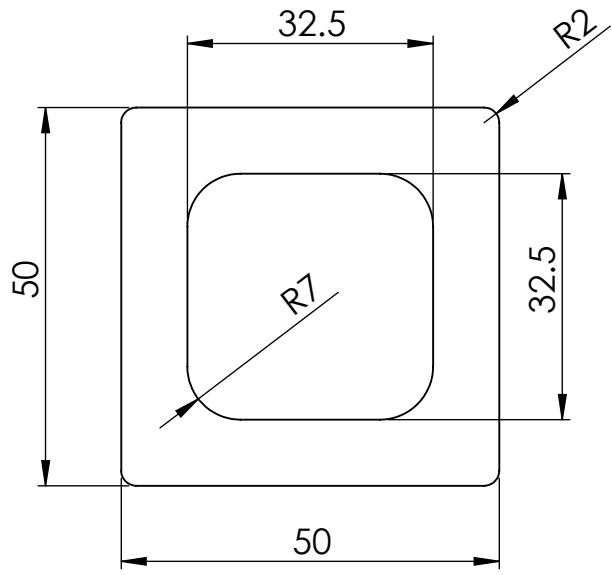

JML	NAMA BAGIAN					POS	BAHAN	UKURAN JADI	UKURAN KASAR	NO. ID	F
>	0	6	30	120	400	1000	PEKERJAAN LANJUT	NO ORDER	PROYEKSI		
<	6	30	120	400	1000	2000					
TOL	±0.1	±0.2	±0.3	±0.5	±0.8	±1.2					
NAMA								SKALA	DIGAMBAR	06/06/22	REYNALDI
KAKI								1 : 1	DIPERIKSA		HILAL
									DISAHKAN		
NO. ASSY :								FORMAT	SATUAN	MPAT/25	
POLITEKNIK NEGERI CILACAP, JURUSAN TEKNIK MESIN JL. dr. SOETOMO, NO : 01, SIDAKAYA, CILACAP, 53121 TELP. 0282 - 533329, E-mail : tmpnc@politeknikcilacap.ac.id								A4	mm		

	5	4	3	2	1		
NO	PERUBAHAN	TANGGAL	NAMA	NO	PERUBAHAN	TANGGAL	NAMA

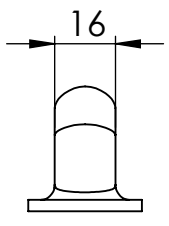
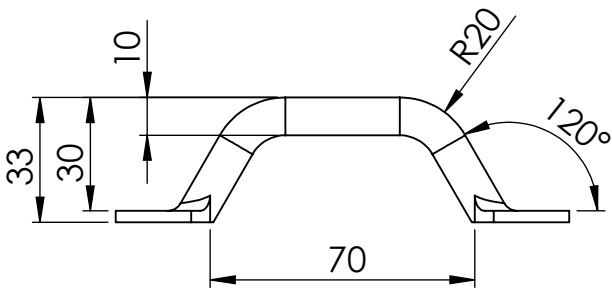
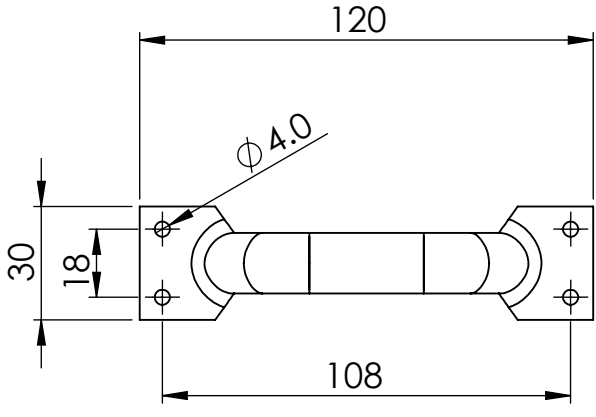

JML	NAMA BAGIAN					POS	BAHAN	UKURAN JADI	UKURAN KASAR	NO. ID	F
>	0	6	30	120	400	1000	PEKERJAAN LANJUT	NO ORDER	PROYEKSI		
<	6	30	120	400	1000	2000					
TOL	±0.1	±0.2	±0.3	±0.5	±0.8	±1.2					
NAMA								SKALA	DIGAMBAR	06/06/22	REYNALDI
GAGANG								1 : 2	DIPERIKSA		HILAL
									DISAHKAN		
NO. ASSY :								FORMAT	SATUAN	MPAT/25	
POLITEKNIK NEGERI CILACAP, JURUSAN TEKNIK MESIN JL. dr. SOETOMO, NO : 01, SIDAKAYA, CILACAP, 53121 TELP. 0282 - 533329, E-mail : tmpnc@politeknikcilacap.ac.id								A4	mm		

PERUBAHAN DARI :

DIGANTI DENGAN :

5		4		3		2		1	
NO	PERUBAHAN	TANGGAL	NAMA	NO	PERUBAHAN	TANGGAL	NAMA		
				△					

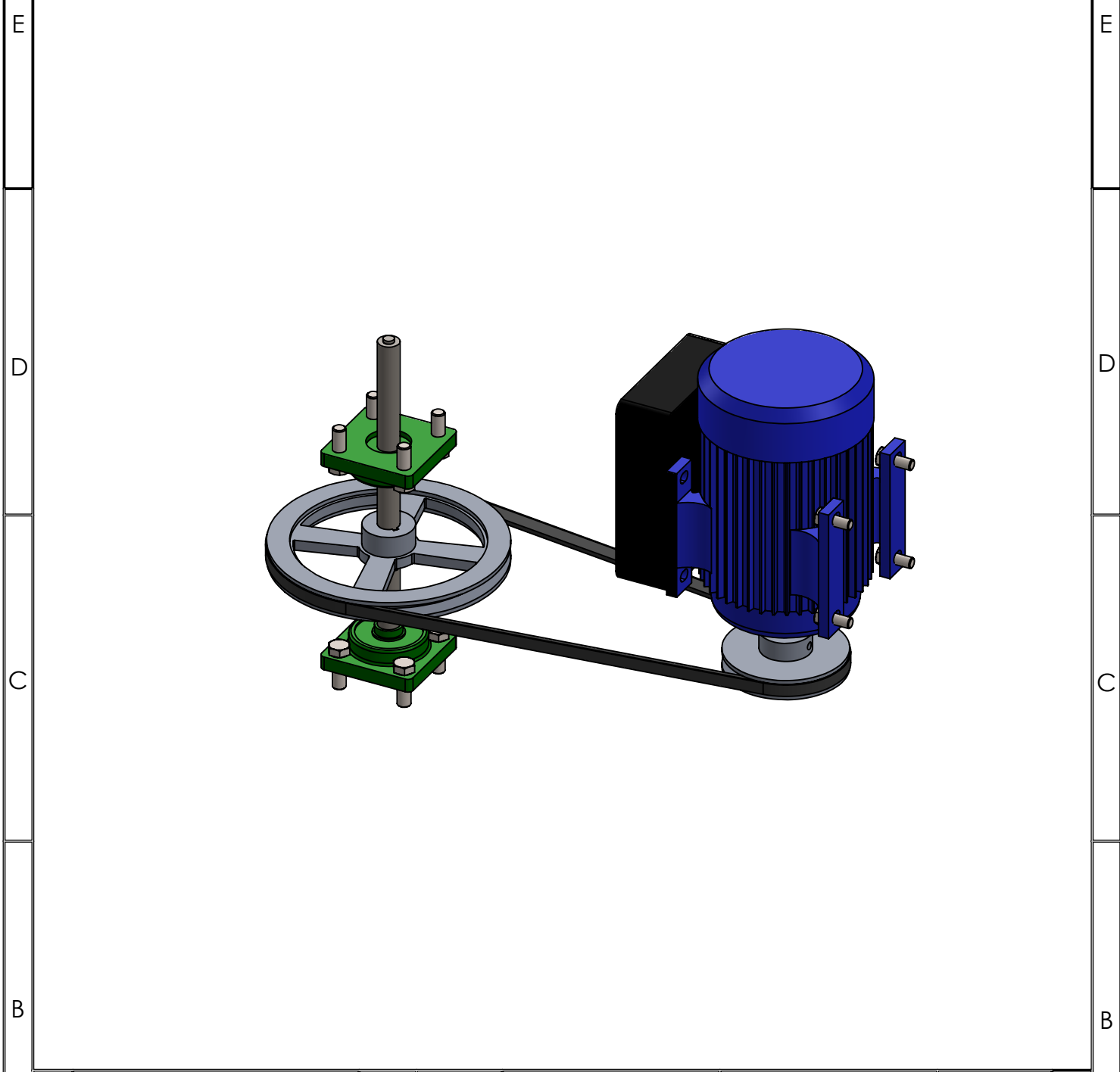

JML	NAMA BAGIAN					POS	BAHAN	UKURAN JADI	UKURAN KASAR	NO. ID	F
>	0	6	30	120	400	1000	PEKERJAAN LANJUT	NO ORDER	PROYEKSI		
<	6	30	120	400	1000	2000					
TOL	±0.1	±0.2	±0.3	±0.5	±0.8	±1.2					
NAMA								SKALA	DIGAMBAR	06/06/22	REYNALDI
SUB ASSEMBLY TRANSMISI								1 : 10	DIPERIKSA		HILAL
									DISAHKAN		
NO. ASSY :								FORMAT	SATUAN	MPAT/26	
POLITEKNIK NEGERI CILACAP, JURUSAN TEKNIK MESIN JL. dr. SOETOMO, NO : 01, SIDAKAYA, CILACAP, 53121 TELP. 0282 - 533329, E-mail : tmpnc@politeknikcilacap.ac.id								A4	mm		

5		4			3		2		1	
NO	PERUBAHAN			TANGGAL	NAMA	NO	PERUBAHAN		TANGGAL	NAMA

JML	NAMA BAGIAN					POS	BAHAN	UKURAN JADI	UKURAN KASAR	NO. ID	F
>	0	6	30	120	400	1000	PEKERJAAN LANJUT	NO ORDER		REYNALDI	
<	6	30	120	400	1000	2000					
TOL	±0.1	±0.2	±0.3	±0.5	±0.8	±1.2					

NAMA <h2 style="text-align: center;">SUB ASSEMBLY TRANSMISI</h2>		SKALA 1 : 10	DIGAMBAR 06/06/22 DIPERIKSA DISAHKAN 	REYNALDI HILAL	
NO. ASSY :		FORMAT A4	SATUAN mm	MPAT/27	

5		4			3		2		1	
---	--	---	--	--	---	--	---	--	---	--

5		4		3		2		1	
NO	PERUBAHAN	TANGGAL	NAMA	NO	PERUBAHAN	TANGGAL	NAMA		
				△					

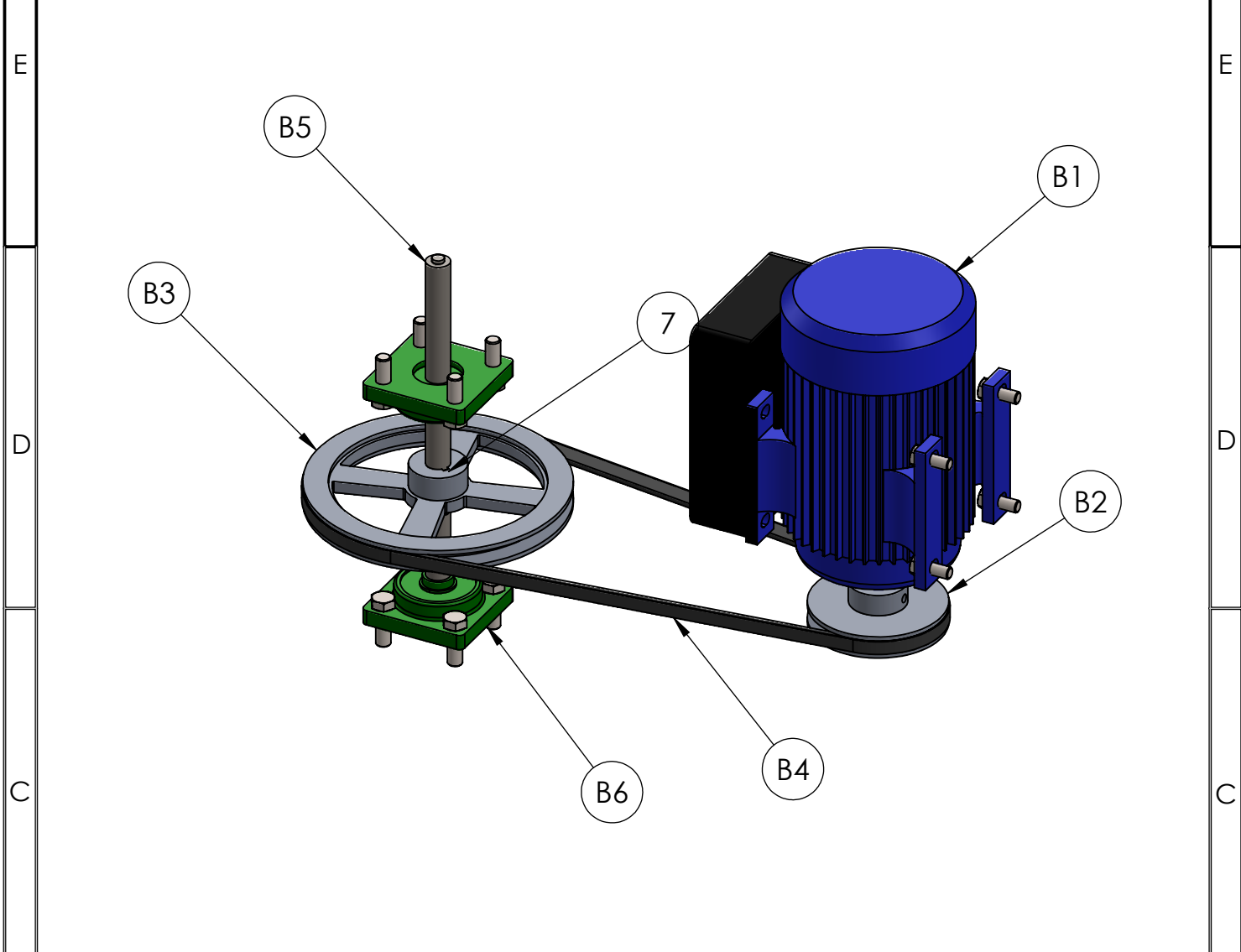

1	MOTOR PENGGERAK			LIHAT DETAIL		B1	
2	PULI PENGGERAK		ALUMINIUM ALLOY	LIHAT DETAIL		B2	
1	PULI YANG DIGERAKKAN		ALUMINIUM ALLOY	LIHAT DETAIL		B3	
1	SABUK V TIPE A NO 50		RUBBER	LIHAT DETAIL		B4	
1	POROS		S45C	LIHAT DETAIL		B5	
1	BEARING			LIHAT DETAIL		B6	
1	PASAK		MILDSTEEL	LIHAT DETAIL		B7	

JML	NAMA BAGIAN					POS	BAHAN	UKURAN JADI	UKURAN KASAR	NO. ID	F
>	0	6	30	120	400	1000	PEKERJAAN LANJUT	NO ORDER	PROYEKSI		
<	6	30	120	400	1000	2000					
TOL	±0.1	±0.2	±0.3	±0.5	±0.8	±1.2					

NAMA				SKALA	DIGAMBAR	06/06/22	REYNALDI
SUB ASSEMBLY TRANSMISI				1 : 5	DIPERIKSA		HILAL
					DISAHKAN		
NO. ASSY :				FORMAT	SATUAN	MPAT/28	
POLITEKNIK NEGERI CILACAP, JURUSAN TEKNIK MESIN JL. dr. SOETOMO, NO : 01, SIDAKAYA, CILACAP, 53121 TELP. 0282 - 533329, E-mail : tmpnc@politeknikcilacap.ac.id				A4	mm		

5		4		3		2		1	
NO	PERUBAHAN	TANGGAL	NAMA	NO	PERUBAHAN	TANGGAL	NAMA		
				△					

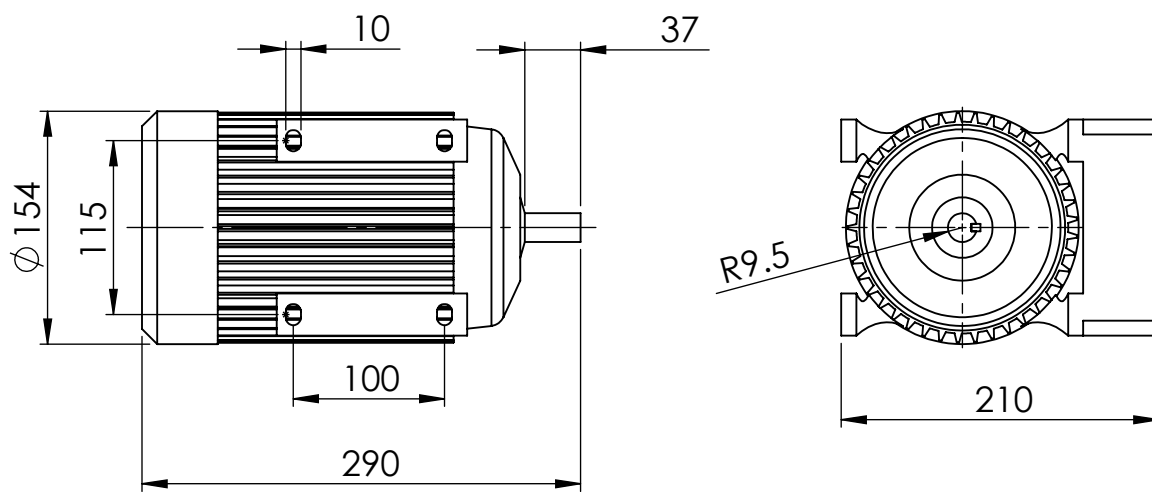

--	--	--	--	--	--	--	--	--	--

JML	NAMA BAGIAN						POS	BAHAN	UKURAN JADI	UKURAN KASAR	NO. ID	F
>	0	6	30	120	400	1000	PEKERJAAN LANJUT		NO ORDER	PROYEKSI		
<	6	30	120	400	1000	2000						
TOL	±0.1	±0.2	±0.3	±0.5	±0.8	±1.2						

NAMA MOTOR PENGGERAK	SKALA	DIGAMBAR	06/06/22	REYNALDI
	1 : 5	DIPERIKSA		HILAL
		DISAHKAN		

NO. ASSY :	POLITEKNIK NEGERI CILACAP, JURUSAN TEKNIK MESIN JL. dr. SOETOMO, NO : 01, SIDAKAYA, CILACAP, 53121 TELP. 0282 - 533329, E-mail : tmpnc@politeknikcilacap.ac.id	FORMAT	SATUAN	MPAT/29
		A4	mm	

5		4		3		2		1	
---	--	---	--	---	--	---	--	---	--

PERUBAHAN DARI : DIGANTI DENGAN :

5		4		3		2		1	
NO	PERUBAHAN	TANGGAL	NAMA	NO	PERUBAHAN	TANGGAL	NAMA		
				△					

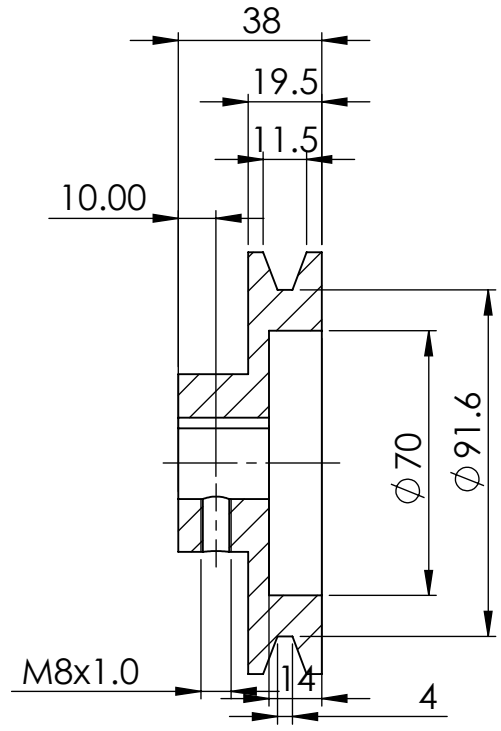
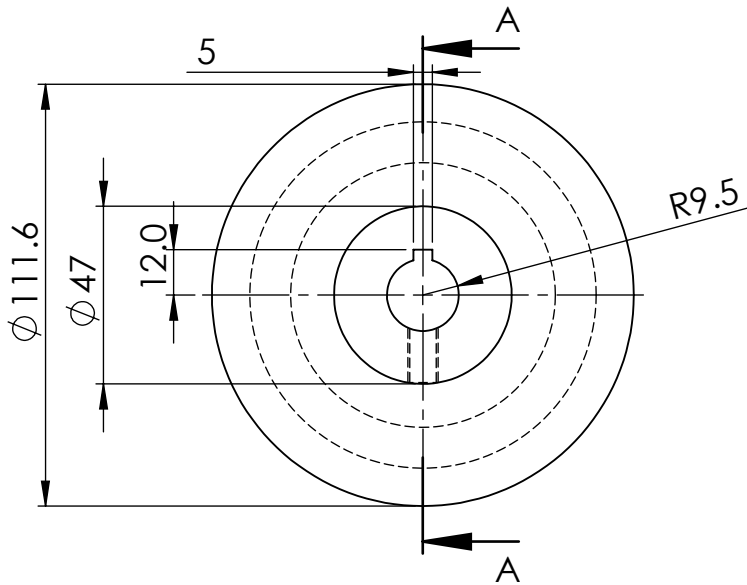

SECTION A-A

JML	NAMA BAGIAN					POS	BAHAN	UKURAN JADI	UKURAN KASAR	NO. ID	F
>	0	6	30	120	400	1000	PEKERJAAN LANJUT	NO ORDER	PROYEKSI		
<	6	30	120	400	1000	2000					
TOL	±0.1	±0.2	±0.3	±0.5	±0.8	±1.2					
NAMA								SKALA	DIGAMBAR	06/06/22	REYNALDI
PULI PENGGERAK								1 : 2	DIPERIKSA		HILAL
									DISAHKAN		
NO. ASSY :								FORMAT	SATUAN	MPAT/30	
POLITEKNIK NEGERI CILACAP, JURUSAN TEKNIK MESIN JL. dr. SOETOMO, NO : 01, SIDAKAYA, CILACAP, 53121 TELP. 0282 - 533329, E-mail : tmpnc@politeknikcilacap.ac.id								A4	mm		

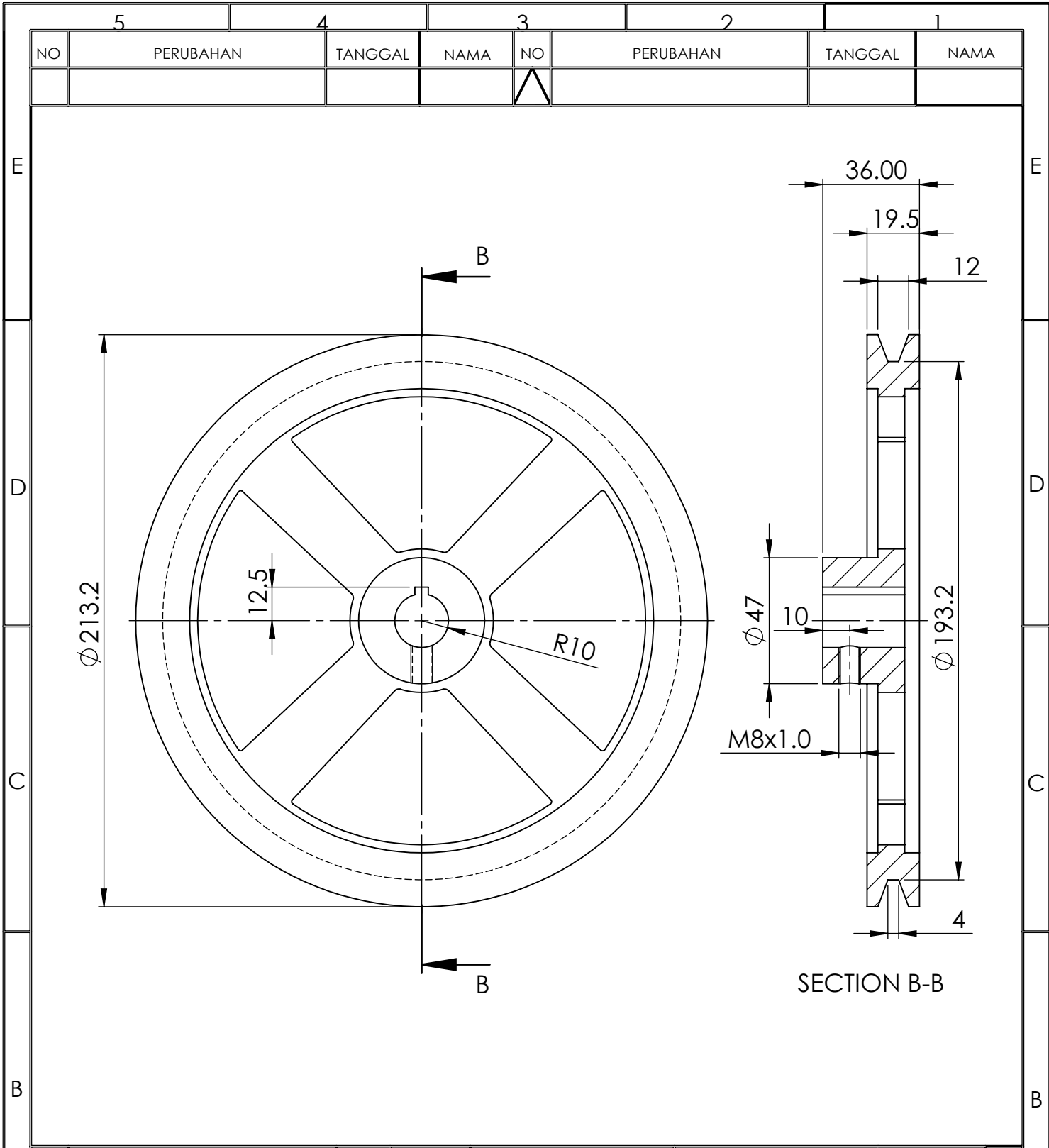

SECTION B-B

JML	NAMA BAGIAN						POS	BAHAN	UKURAN JADI	UKURAN KASAR	NO. ID	F
>	0	6	30	120	400	1000	PEKERJAAN LANJUT		NO ORDER	PROYEKSI		
<	6	30	120	400	1000	2000						
TOL	±0.1	±0.2	±0.3	±0.5	±0.8	±1.2						
NAMA									SKALA	DIGAMBAR	06/06/22	REYNALDI
PULI YANG DIGERAKKAN									1 : 2	DIPERIKSA		HILAL
										DISAHKAN		
NO. ASSY :									FORMAT	SATUAN	MPAT/31	
POLITEKNIK NEGERI CILACAP, JURUSAN TEKNIK MESIN JL. dr. SOETOMO, NO : 01, SIDAKAYA, CILACAP, 53121 TELP. 0282 - 533329, E-mail : tmpnc@politeknikcilacap.ac.id									A4	mm		

5		4		3		2		1	
NO	PERUBAHAN	TANGGAL	NAMA	NO	PERUBAHAN	TANGGAL	NAMA		
				△					

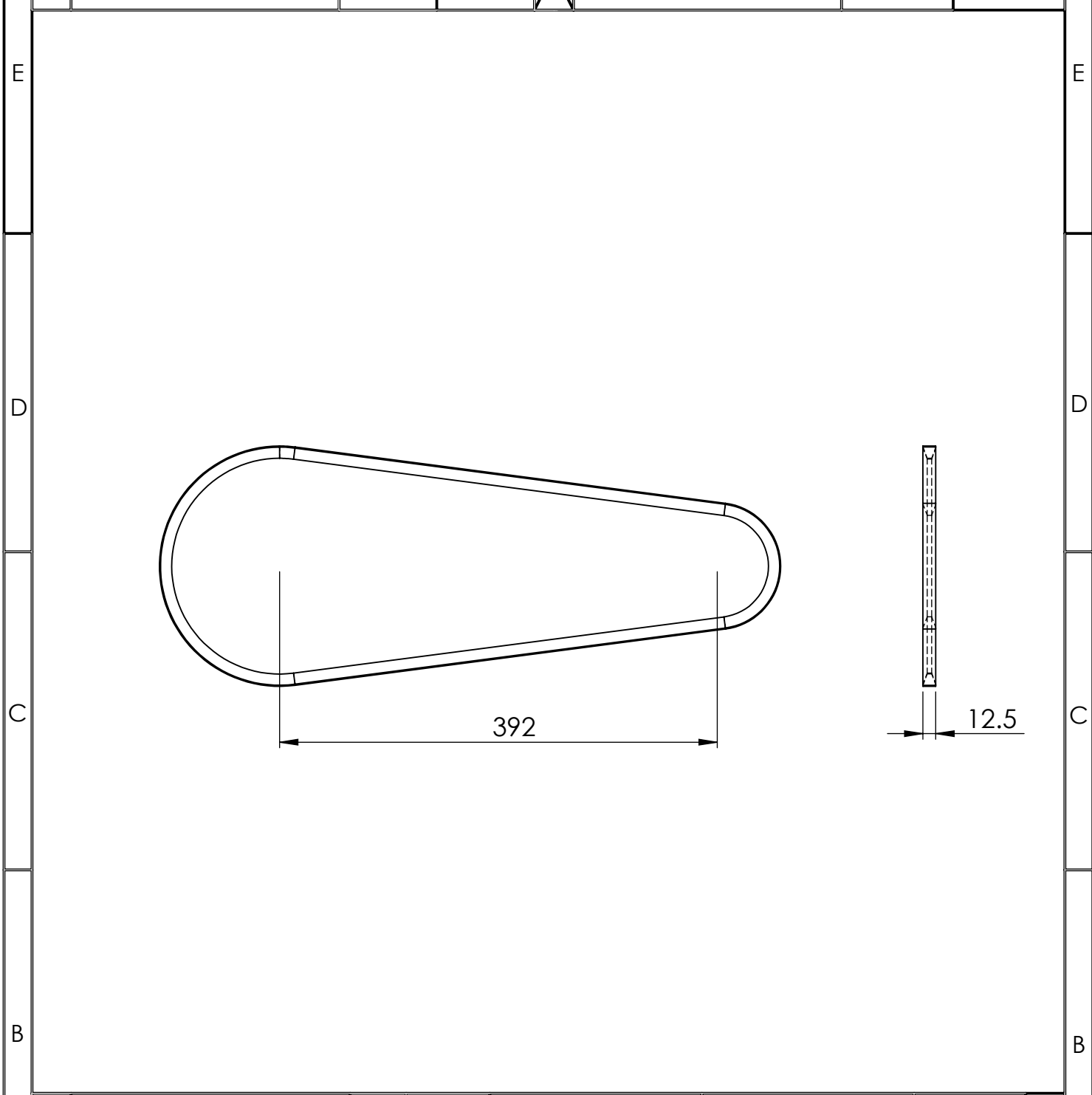

JML	NAMA BAGIAN					POS	BAHAN	UKURAN JADI	UKURAN KASAR	NO. ID	F
>	0	6	30	120	400	1000	PEKERJAAN LANJUT	NO ORDER	PROYEKSI		
<	6	30	120	400	1000	2000					
TOL	±0.1	±0.2	±0.3	±0.5	±0.8	±1.2					
NAMA								SKALA	DIGAMBAR	06/06/22	REYNALDI
SABUK V TIPE A NO 50								1 : 5	DIPERIKSA		HILAL
									DISAHKAN		
NO. ASSY :								FORMAT	SATUAN	MPAT/32	
POLITEKNIK NEGERI CILACAP, JURUSAN TEKNIK MESIN JL. dr. SOETOMO, NO : 01, SIDAKAYA, CILACAP, 53121 TELP. 0282 - 533329, E-mail : tmpnc@politeknikcilacap.ac.id								A4	mm		

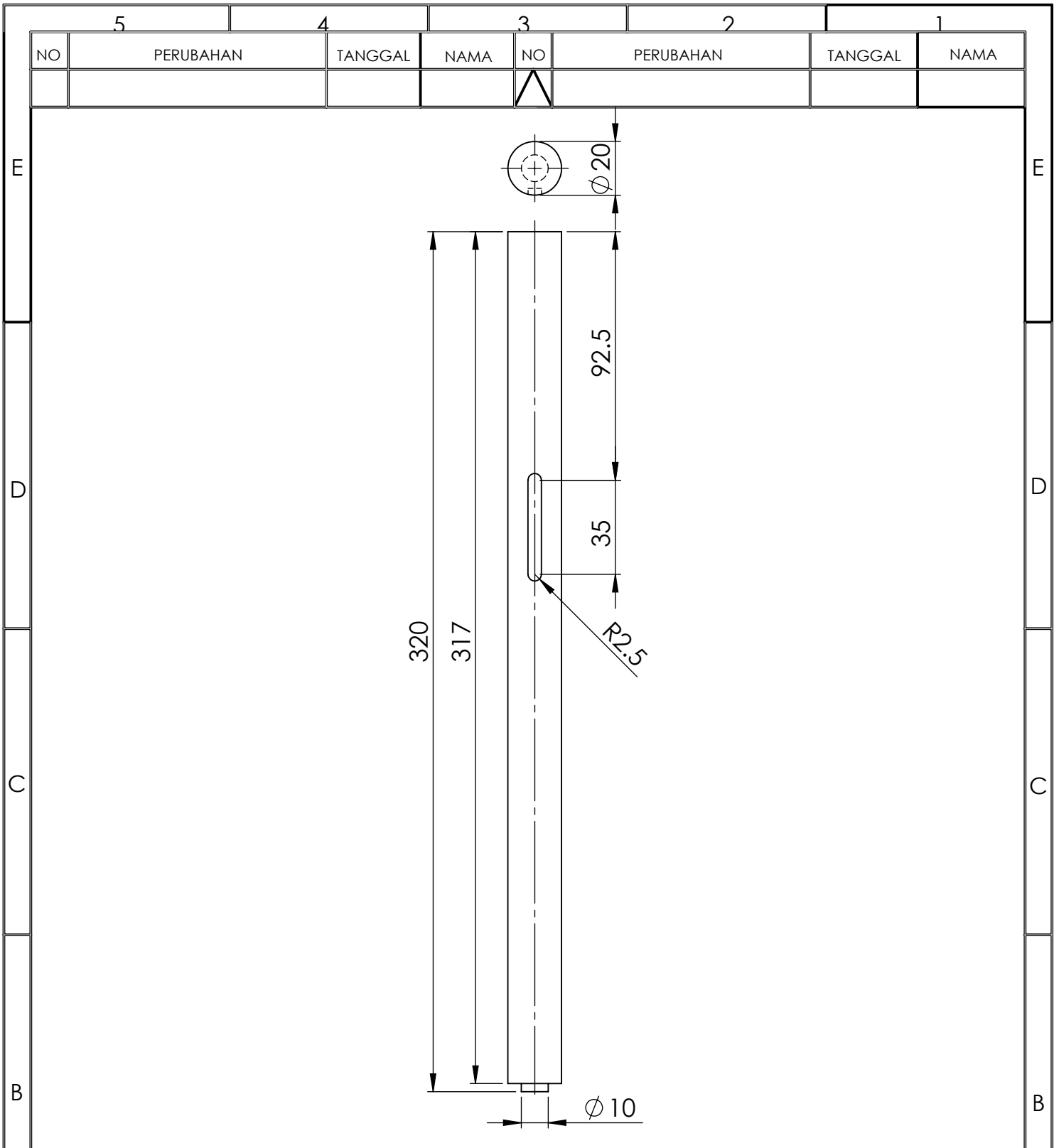

JML	NAMA BAGIAN						POS	BAHAN	UKURAN JADI	UKURAN KASAR	NO. ID	F
>	0	6	30	120	400	1000	PEKERJAAN LANJUT		NO ORDER			
<	6	30	120	400	1000	2000						
TOL	±0.1	±0.2	±0.3	±0.5	±0.8	±1.2						
NAMA POROS									SKALA 1 : 5	DIGAMBAR 06/06/22	REYNALDI	A
NO. ASSY :									DIPERIKSA		HILAL	
									DISAHKAN			
POLITEKNIK NEGERI CILACAP, JURUSAN TEKNIK MESIN JL. dr. SOETOMO, NO : 01, SIDAKAYA, CILACAP, 53121 TELP. 0282 - 533329, E-mail : tmpnc@politeknikcilacap.ac.id									FORMAT A4	SATUAN mm	MPAT/33	

PERUBAHAN DARI :

DIGANTI DENGAN :

5		4		3		2		1	
NO	PERUBAHAN	TANGGAL	NAMA	NO	PERUBAHAN	TANGGAL	NAMA		
				△					

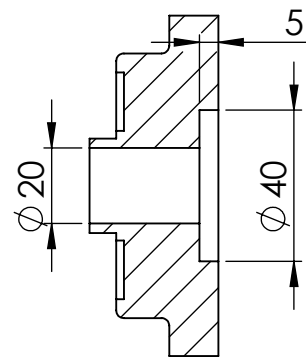
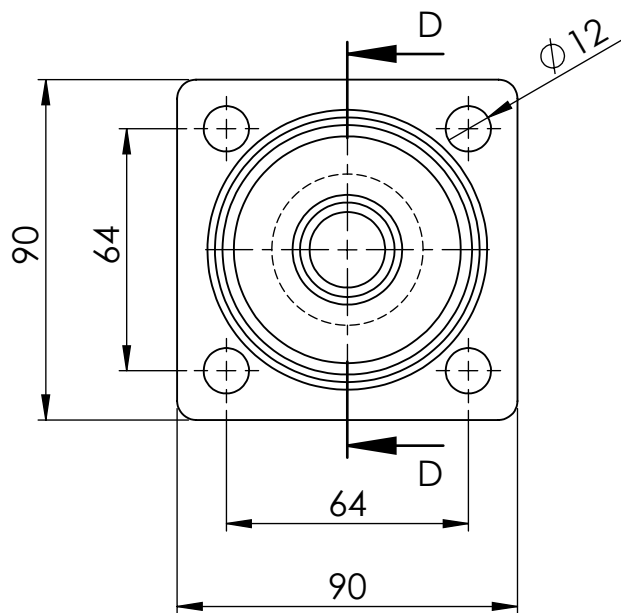

SECTION D-D

--	--	--	--	--	--	--	--	--	--

JML	NAMA BAGIAN						POS	BAHAN	UKURAN JADI	UKURAN KASAR	NO. ID	F
>	0	6	30	120	400	1000	PEKERJAAN LANJUT		NO ORDER	PROYEKSI		
<	6	30	120	400	1000	2000						
TOL	±0.1	±0.2	±0.3	±0.5	±0.8	±1.2						

NAMA	BEARING						SKALA	DIGAMBAR	06/06/22	REYNALDI
								DIPERIKSA		HILAL
								DISAHKAN		



NO. ASSY :	POLITEKNIK NEGERI CILACAP, JURUSAN TEKNIK MESIN						FORMAT	SATUAN	MPAT/34
	JL. dr. SOETOMO, NO : 01, SIDAKAYA, CILACAP, 53121						A4	mm	
	TELP. 0282 - 533329, E-mail : tmpnc@politeknikcilacap.ac.id								

5		4		3		2		1	
---	--	---	--	---	--	---	--	---	--

PERUBAHAN DARI : DIGANTI DENGAN :

	5		4		3		2		1
NO	PERUBAHAN	TANGGAL	NAMA	NO	PERUBAHAN	TANGGAL	NAMA		
				^					

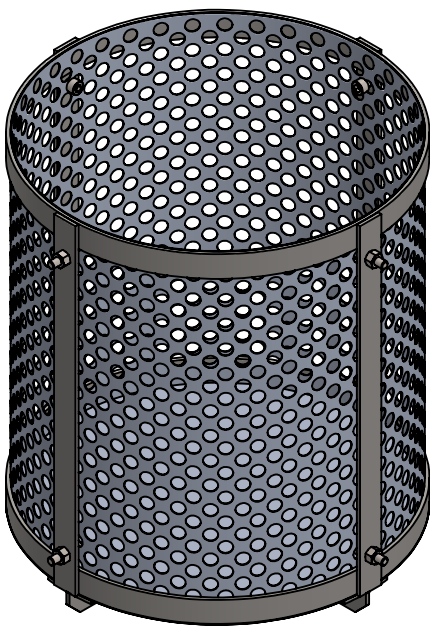
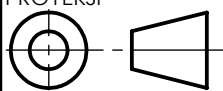
JML	NAMA BAGIAN					POS	BAHAN	UKURAN JADI	UKURAN KASAR	NO. ID	F
>	0	6	30	120	400	1000	PEKERJAAN LANJUT	NO ORDER			
<	6	30	120	400	1000	2000					
TOL	±0.1	±0.2	±0.3	±0.5	±0.8	±1.2					
NAMA								SKALA	DIGAMBAR	06/06/22	REYNALDI
PASAK								2 : 1	DIPERIKSA		HILAL
									DISAHKAN		
NO. ASSY :								FORMAT	SATUAN	MPAT/35	
POLITEKNIK NEGERI CILACAP, JURUSAN TEKNIK MESIN JL. dr. SOETOMO, NO : 01, SIDAKAYA, CILACAP, 53121 TELP. 0282 - 533329, E-mail : tmpnc@politeknikcilacap.ac.id								A4	mm		

5		4			3		2		1			
NO	PERUBAHAN	TANGGAL	NAMA	NO	PERUBAHAN	TANGGAL	NAMA					
				^								
E											E	
D											D	
C											C	
B											B	
JML	NAMA BAGIAN					POS	BAHAN	UKURAN JADI	UKURAN KASAR	NO. ID	F	
>	0	6	30	120	400	1000	PEKERJAAN LANJUT		NO ORDER		PROYEKSI 	
<	6	30	120	400	1000	2000						
TOL	±0.1	±0.2	±0.3	±0.5	±0.8	±1.2						
NAMA								SKALA	DIGAMBAR	06/06/22	REYNALDI	
SUB ASSEMBLY TABUNG PUTAR								1 : 5	DIPERIKSA		HILAL	
									DISAHKAN			
NO. ASSY :								FORMAT	SATUAN	MPAT/36		
 POLITEKNIK NEGERI CILACAP, JURUSAN TEKNIK MESIN JL. dr. SOETOMO, NO : 01, SIDAKAYA, CILACAP, 53121 TELP. 0282 - 533329, E-mail : tmpnc@politeknikcilacap.ac.id								A4	mm			
5		4			3		2		1			

PERUBAHAN DARI :

DIGANTI DENGAN :

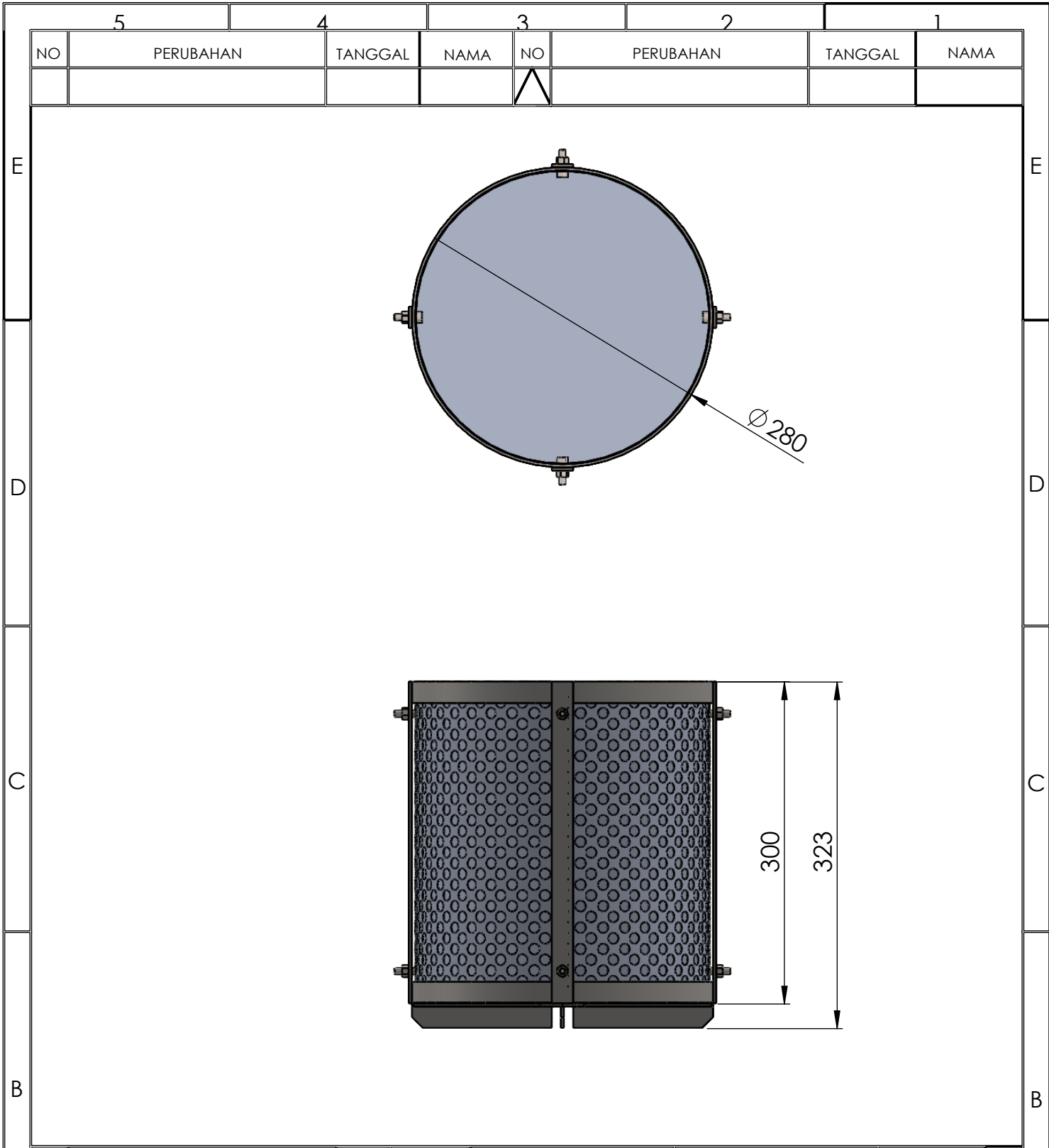

JML	NAMA BAGIAN						POS	BAHAN	UKURAN JADI	UKURAN KASAR	NO. ID	F
>	0	6	30	120	400	1000	PEKERJAAN LANJUT		NO ORDER	PROYEKSI		
<	6	30	120	400	1000	2000						
TOL	±0.1	±0.2	±0.3	±0.5	±0.8	±1.2						
NAMA									SKALA	DIGAMBAR	06/06/22	REYNALDI
SUB ASSEMBLY TABUNG PUTAR									1 : 5	DIPERIKSA		HILAL
										DISAHKAN		
NO. ASSY :									FORMAT	SATUAN	MPAT/37	
POLITEKNIK NEGERI CILACAP, JURUSAN TEKNIK MESIN JL. dr. SOETOMO, NO : 01, SIDAKAYA, CILACAP, 53121 TELP. 0282 - 533329, E-mail : tmpnc@politeknikcilacap.ac.id									A4	mm		

PERUBAHAN DARI :

DIGANTI DENGAN :

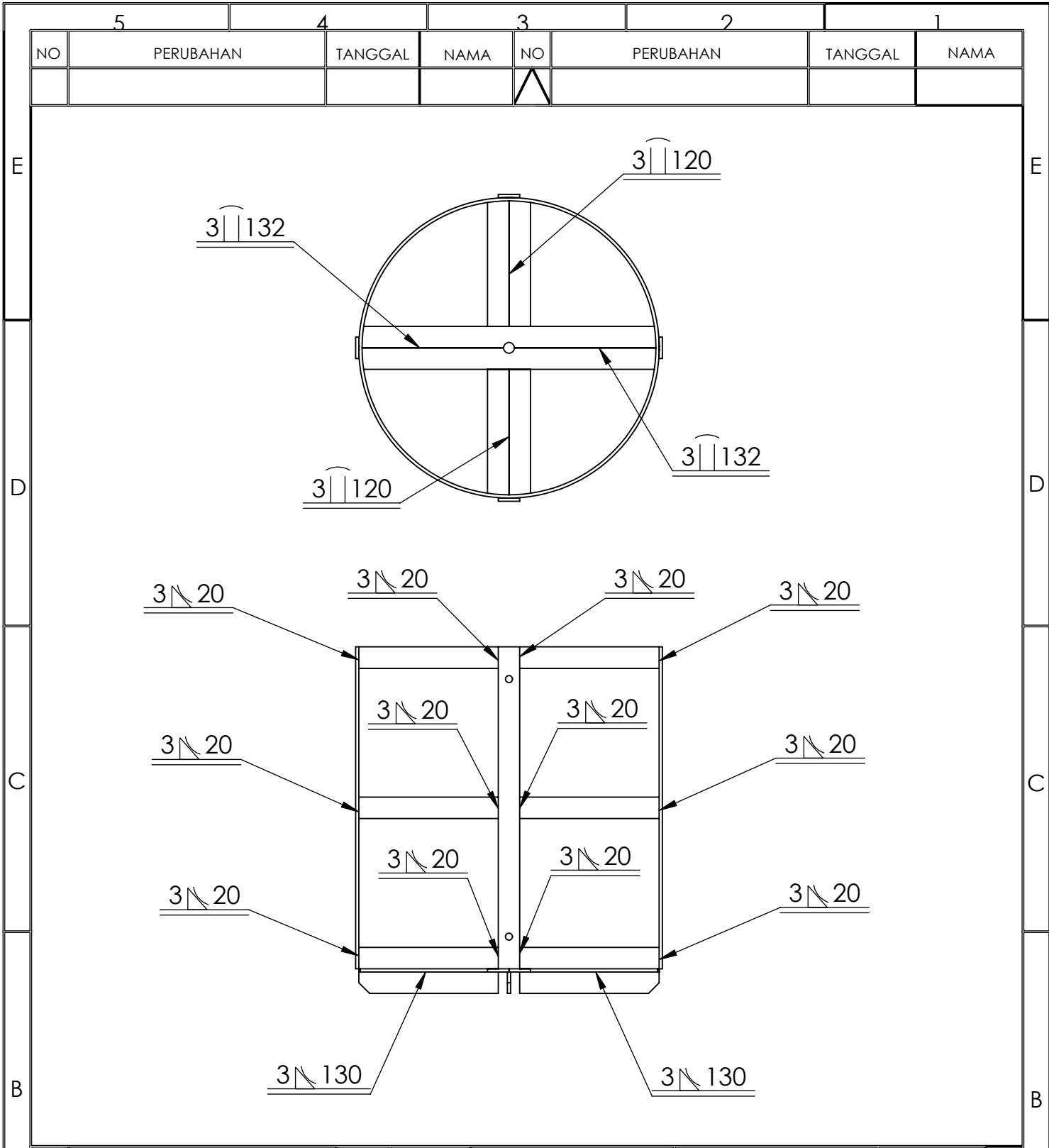

JML	NAMA BAGIAN						POS	BAHAN	UKURAN JADI	UKURAN KASAR	NO. ID	F
>	0	6	30	120	400	1000	PEKERJAAN LANJUT		NO ORDER	PROYEKSI		
<	6	30	120	400	1000	2000						
TOL	±0.1	±0.2	±0.3	±0.5	±0.8	±1.2						

NAMA SUB ASSEMBLY TABUNG PUTAR	SKALA 1 : 5	DIGAMBAR	06/06/22	REYNALDI
		DIPERIKSA		HILAL
		DISAHKAN		
NO. ASSY :	FORMAT A4	SATUAN mm	MPAT/38	

5		4		3		2		1			
NO	PERUBAHAN	TANGGAL	NAMA	NO	PERUBAHAN	TANGGAL	NAMA				
				△							
1	TABUNG PENYARING		ALUMINIUM ALLOY 1100	LIHAT DETAIL			C1				
1	ALAS TABUNG		ALUMINIUM ALLOY 1100	LIHAT DETAIL			C2				
2	RANGKA MELINGKAR		STAINLESS STEEL 304	LIHAT DETAIL			C3				
4	RANGKA VERTIKAL		STAINLESS STEEL 304	LIHAT DETAIL			C4				
2	RANGKA HORIZONTAL 1		STAINLESS STEEL 304	LIHAT DETAIL			C5				
4	RANGKA HORIZONTAL 2		STAINLESS STEEL 304	LIHAT DETAIL			C6				
4	RANGKA HORIZONTAL 3		STAINLESS STEEL 304	LIHAT DETAIL			C7				
JML	NAMA BAGIAN					POS	BAHAN	UKURAN JADI	UKURAN KASAR	NO. ID	F
>	0	6	30	120	400	1000	PEKERJAAN LANJUT	NO ORDER	PROYEKSI 		
<	6	30	120	400	1000	2000					
TOL	±0.1	±0.2	±0.3	±0.5	±0.8	±1.2					
NAMA SUB ASSEMBLY TABUNG PUTAR								SKALA 1 : 10	DIGAMBAR 06/06/22 REYNALDI	DIPERIKSA HILAL	DISAHKAN
NO. ASSY :								FORMAT A4	SATUAN mm	MPAT/39	
POLITEKNIK NEGERI CILACAP, JURUSAN TEKNIK MESIN JL. dr. SOETOMO, NO : 01, SIDAKAYA, CILACAP, 53121 TELP. 0282 - 533329, E-mail : tmpnc@politeknikcilacap.ac.id											
5		4		3		2		1			

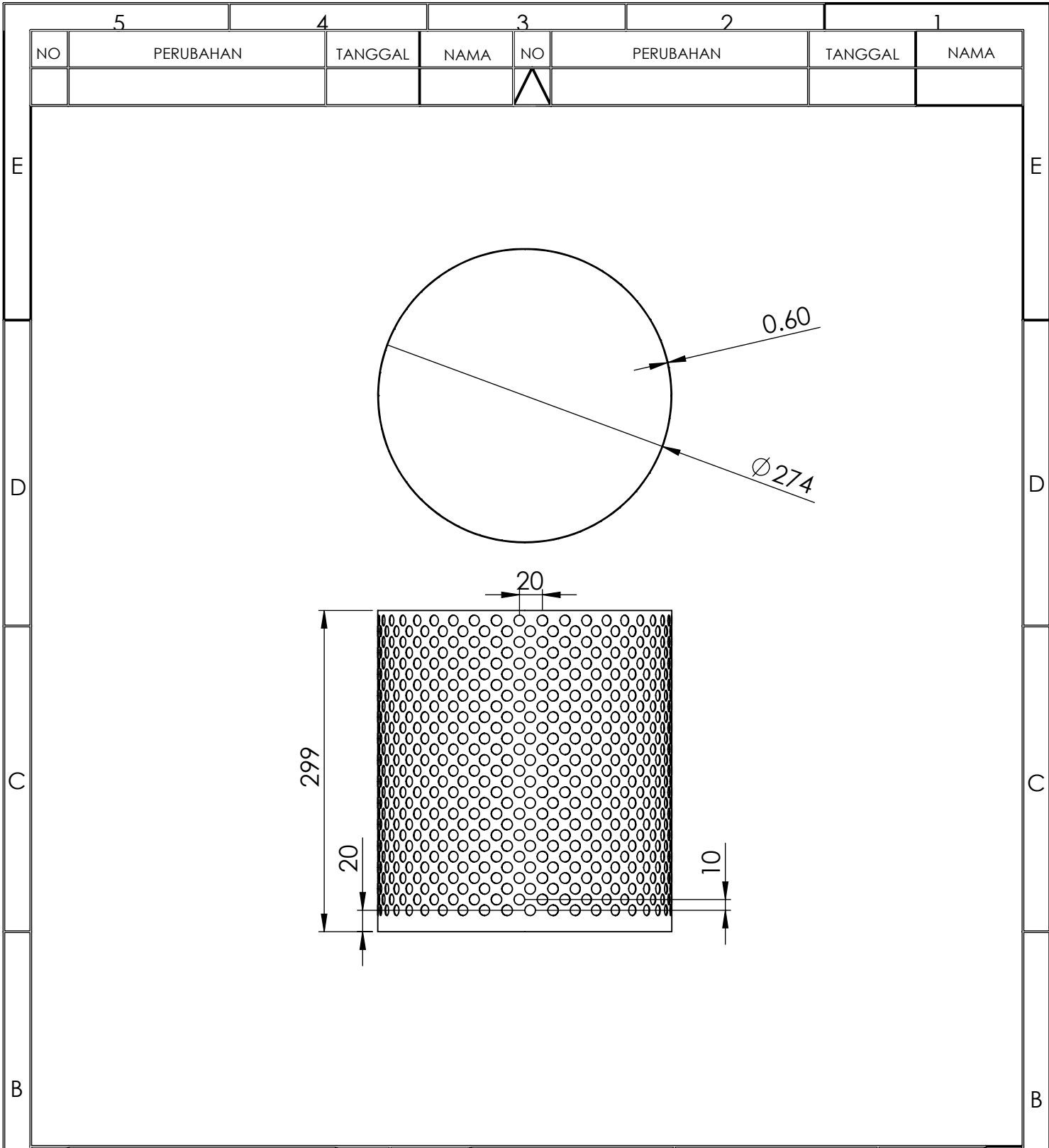

JML	NAMA BAGIAN						POS	BAHAN	UKURAN JADI	UKURAN KASAR	NO. ID	F
>	0	6	30	120	400	1000	PEKERJAAN LANJUT		NO ORDER			
<	6	30	120	400	1000	2000						
TOL	±0.1	±0.2	±0.3	±0.5	±0.8	±1.2						
NAMA TABUNG PENYARING									SKALA 1 : 5	DIGAMBAR 06/06/22 DIPERIKSA DISAHKAN	REYNALDI HILAL	
NO. ASSY :									FORMAT A4	SATUAN mm	MPAT/40	

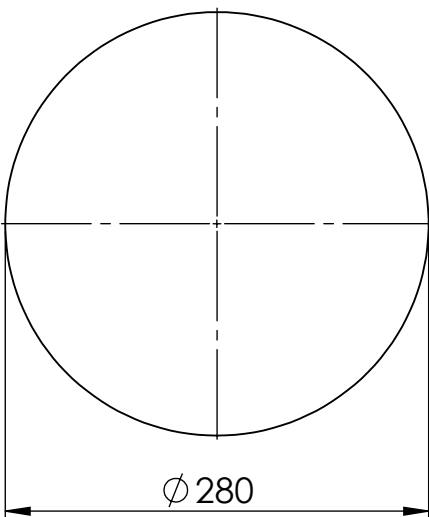

	5	4	3	2	1		
NO	PERUBAHAN	TANGGAL	NAMA	NO	PERUBAHAN	TANGGAL	NAMA

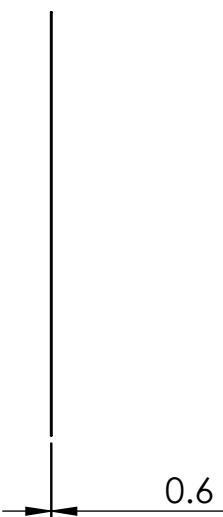

Ø 280

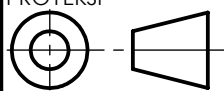

0.6

JML	NAMA BAGIAN					POS	BAHAN	UKURAN JADI	UKURAN KASAR	NO. ID	F
>	0	6	30	120	400	1000	PEKERJAAN LANJUT	NO ORDER		REYNALDI	HILAL
<	6	30	120	400	1000	2000					
TOL	±0.1	±0.2	±0.3	±0.5	±0.8	±1.2					
NAMA ALAS TABUNG								SKALA 1 : 5	DIGAMBAR	06/06/22	REYNALDI
NO. ASSY :								DIPERIKSA			
 POLITEKNIK NEGERI CILACAP, JURUSAN TEKNIK MESIN JL. dr. SOETOMO, NO : 01, SIDAKAYA, CILACAP, 53121 TELP. 0282 - 533329, E-mail : tmpnc@politeknikcilacap.ac.id								FORMAT A4	SATUAN mm	MPAT/41	

PERUBAHAN DARI :

DIGANTI DENGAN :

5		4		3		2		1	
NO	PERUBAHAN	TANGGAL	NAMA	NO	PERUBAHAN	TANGGAL	NAMA		
				△					

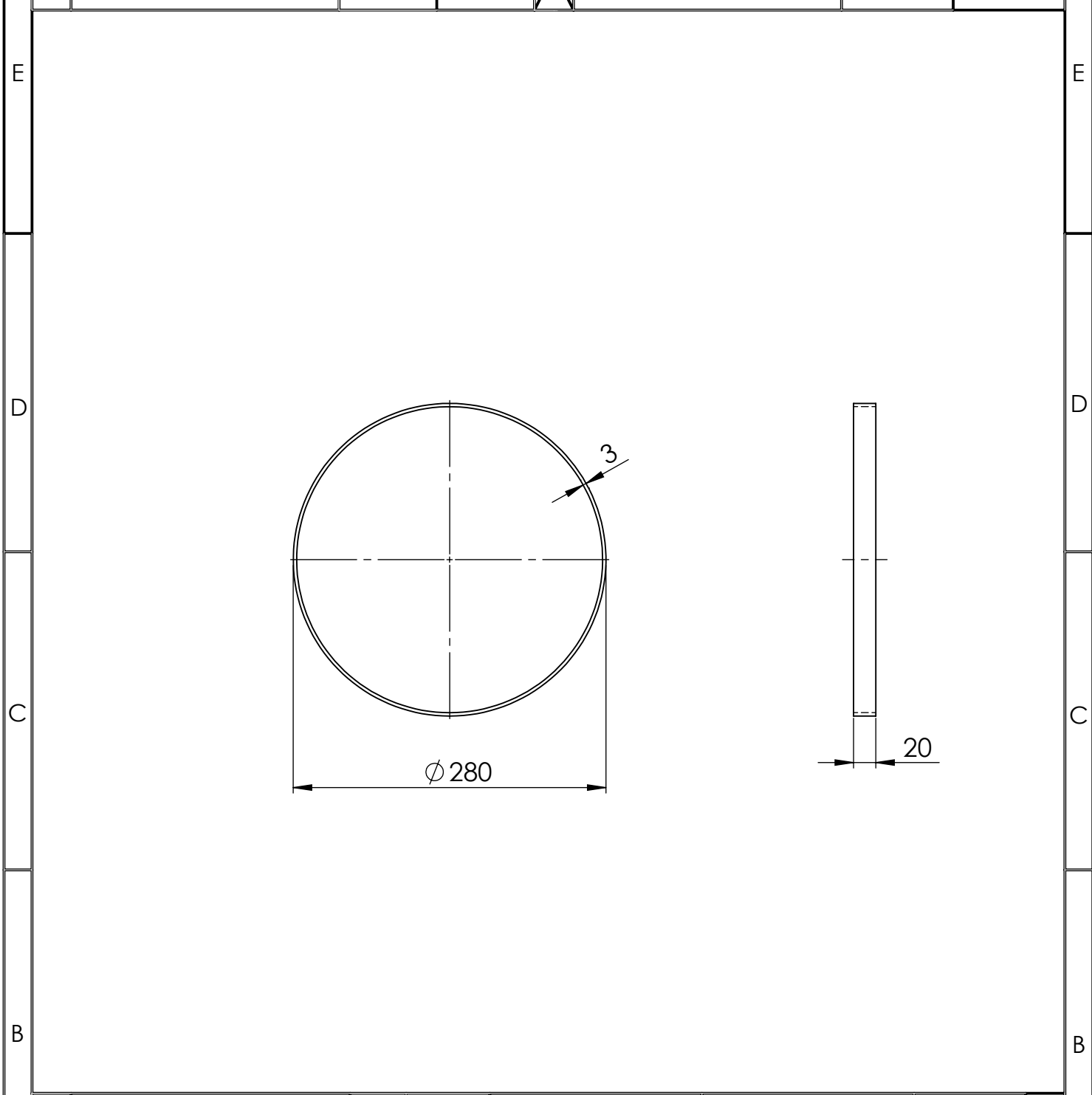

JML	NAMA BAGIAN					POS	BAHAN	UKURAN JADI	UKURAN KASAR	NO. ID	F
>	0	6	30	120	400	1000	PEKERJAAN LANJUT	NO ORDER			
<	6	30	120	400	1000	2000					
TOL	±0.1	±0.2	±0.3	±0.5	±0.8	±1.2					
NAMA								SKALA	DIGAMBAR	06/06/22	REYNALDI
RANGKA MELINGKAR								1 : 5	DIPERIKSA		HILAL
									DISAHKAN		
NO. ASSY :								FORMAT	SATUAN	MPAT/42	
POLITEKNIK NEGERI CILACAP, JURUSAN TEKNIK MESIN JL. dr. SOETOMO, NO : 01, SIDAKAYA, CILACAP, 53121 TELP. 0282 - 533329, E-mail : tmpnc@politeknikcilacap.ac.id								A4	mm		

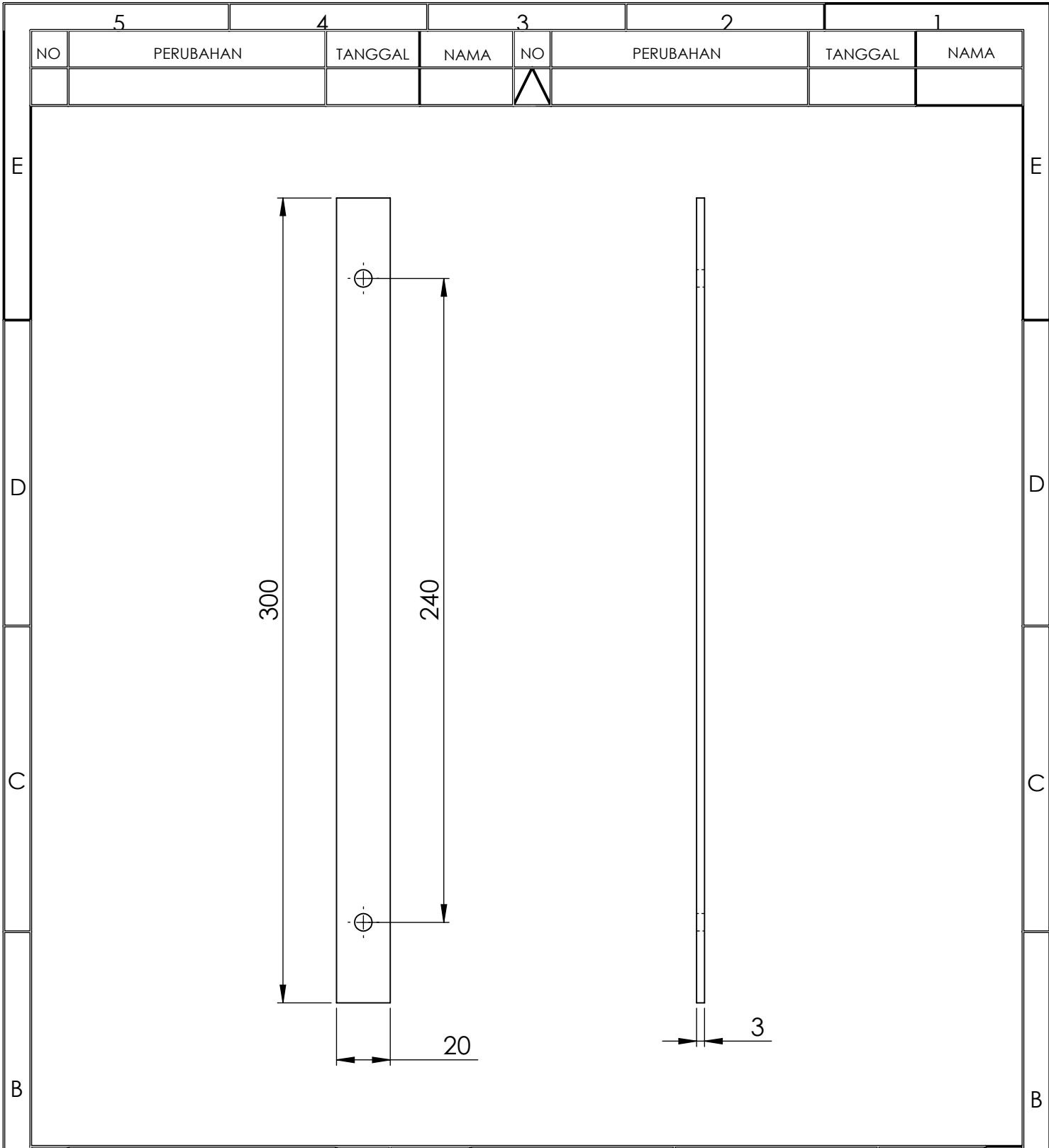

JML	NAMA BAGIAN						POS	BAHAN	UKURAN JADI	UKURAN KASAR	NO. ID	F
>	0	6	30	120	400	1000	PEKERJAAN LANJUT		NO ORDER			
<	6	30	120	400	1000	2000						
TOL	±0.1	±0.2	±0.3	±0.5	±0.8	±1.2						
NAMA									SKALA	DIGAMBAR	06/06/22	REYNALDI
RANGKA VERTIKAL									1 : 5	DIPERIKSA		HILAL
										DISAHKAN		
NO. ASSY :									FORMAT	SATUAN	MPAT/43	
POLITEKNIK NEGERI CILACAP, JURUSAN TEKNIK MESIN JL. dr. SOETOMO, NO : 01, SIDAKAYA, CILACAP, 53121 TELP. 0282 - 533329, E-mail : tmpnc@politeknikcilacap.ac.id									A4	mm		

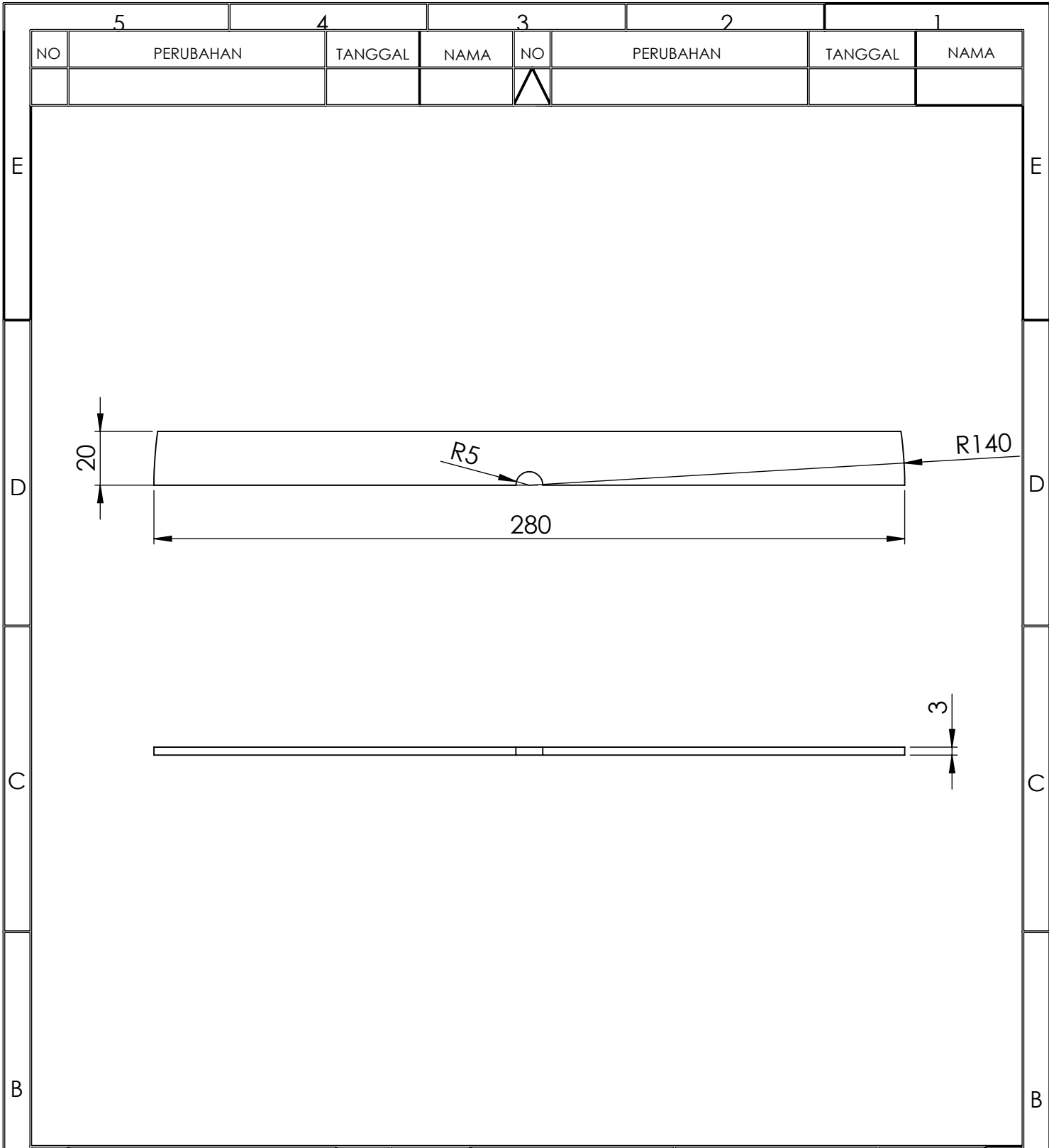

JML	NAMA BAGIAN						POS	BAHAN	UKURAN JADI	UKURAN KASAR	NO. ID	F
>	0	6	30	120	400	1000	PEKERJAAN LANJUT		NO ORDER	PROYEKSI		
<	6	30	120	400	1000	2000						
TOL	±0.1	±0.2	±0.3	±0.5	±0.8	±1.2						
NAMA									SKALA	DIGAMBAR	06/06/22	REYNALDI
RANGKA HORIZONTAL 1									1 : 5	DIPERIKSA		HILAL
										DISAHKAN		
NO. ASSY :									FORMAT	SATUAN	MPAT/ 44	
POLITEKNIK NEGERI CILACAP, JURUSAN TEKNIK MESIN JL. dr. SOETOMO, NO : 01, SIDAKAYA, CILACAP, 53121 TELP. 0282 - 533329, E-mail : tmpnc@politeknikcilacap.ac.id									A4	mm		

5		4		3		2		1	
NO	PERUBAHAN	TANGGAL	NAMA	NO	PERUBAHAN	TANGGAL	NAMA		
				△					

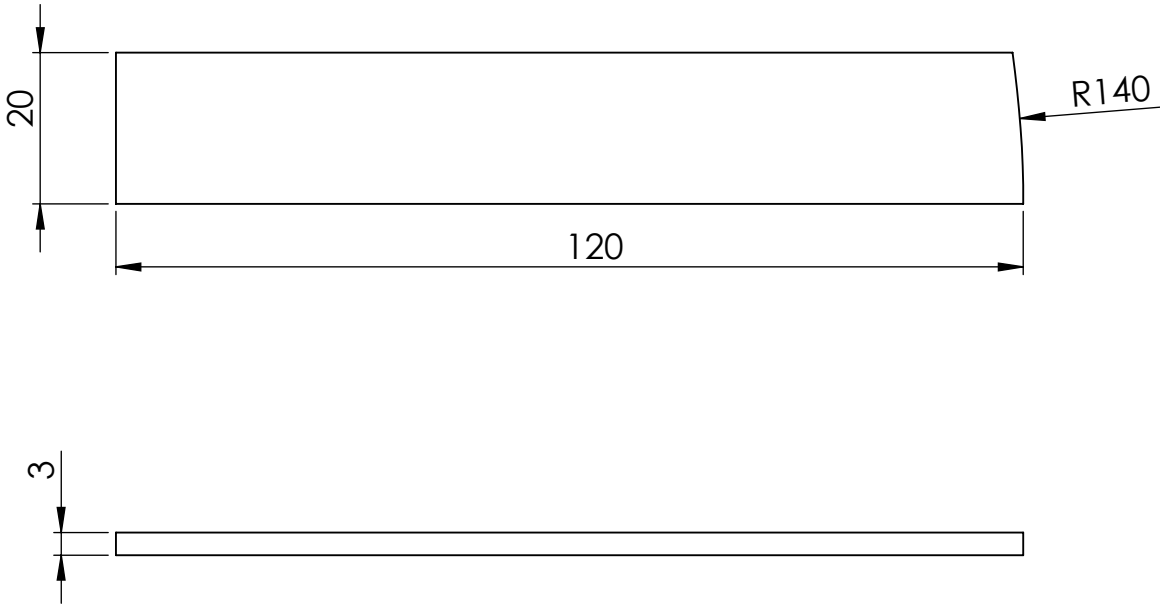

JML	NAMA BAGIAN					POS	BAHAN	UKURAN JADI	UKURAN KASAR	NO. ID	F
>	0	6	30	120	400	1000	PEKERJAAN LANJUT	NO ORDER	PROYEKSI		
<	6	30	120	400	1000	2000					
TOL	±0.1	±0.2	±0.3	±0.5	±0.8	±1.2					
NAMA								SKALA	DIGAMBAR	06/06/22	REYNALDI
RANGKA HORIZONTAL 2								1 : 2	DIPERIKSA		HILAL
									DISAHKAN		
NO. ASSY :								FORMAT	SATUAN	MPAT/45	
POLITEKNIK NEGERI CILACAP, JURUSAN TEKNIK MESIN JL. dr. SOETOMO, NO : 01, SIDAKAYA, CILACAP, 53121 TELP. 0282 - 533329, E-mail : tmpnc@politeknikcilacap.ac.id								A4	mm		

PERUBAHAN DARI :

DIGANTI DENGAN :

	5		4		3		2		1
NO	PERUBAHAN	TANGGAL	NAMA	NO	PERUBAHAN	TANGGAL	NAMA	NO	PERUBAHAN
				/					

E
E

D
D



C
C

B
B

A
A

JML	NAMA BAGIAN					POS	BAHAN	UKURAN JADI	UKURAN KASAR	NO. ID	F	
>	0	6	30	120	400	1000	PEKERJAAN LANJUT		NO ORDER		PROYEKSI	
<	6	30	120	400	1000	2000						
TOL	±0.1	±0.2	±0.3	±0.5	±0.8	±1.2						
NAMA								SKALA	DIGAMBAR	06/06/22	REYNALDI	
RANGKA HORIZONTAL 3								1 : 2	DIPERIKSA		HILAL	
NO. ASSY :								DISAHKAN				
POLITEKNIK NEGERI CILACAP, JURUSAN TEKNIK MESIN JL. dr. SOETOMO, NO : 01, SIDAKAYA, CILACAP, 53121 TELP. 0282 - 533329, E-mail : tmpnc@politeknikcilacap.ac.id								FORMAT	SATUAN	MPAT/46		
								A4	mm			

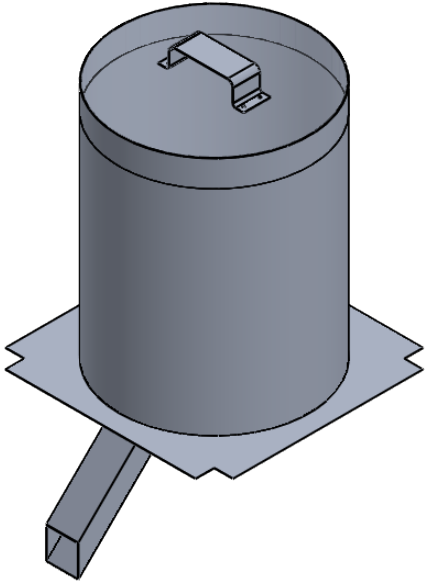
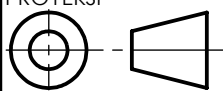
	5		4		3		2		1
PERUBAHAN DARI :									DIGANTI DENGAN :

5		4			3		2		1			
NO	PERUBAHAN	TANGGAL	NAMA	NO	PERUBAHAN	TANGGAL	NAMA					
				^								
E											E	
D											D	
C											C	
B											B	
JML	NAMA BAGIAN					POS	BAHAN	UKURAN JADI	UKURAN KASAR	NO. ID	F	
>	0	6	30	120	400	1000	PEKERJAAN LANJUT		NO ORDER		PROYEKSI 	
<	6	30	120	400	1000	2000						
TOL	±0.1	±0.2	±0.3	±0.5	±0.8	±1.2						
NAMA								SKALA	DIGAMBAR	06/06/22	REYNALDI	
TABUNG PENAMPUNG								1 : 10	DIPERIKSA		HILAL	
									DISAHKAN			
NO. ASSY :								FORMAT	SATUAN	MPAT/47		
 POLITEKNIK NEGERI CILACAP, JURUSAN TEKNIK MESIN JL. dr. SOETOMO, NO : 01, SIDAKAYA, CILACAP, 53121 TELP. 0282 - 533329, E-mail : tmpnc@politeknikcilacap.ac.id								A4	mm			
5		4			3		2		1			

5		4		3		2		1	
NO	PERUBAHAN	TANGGAL	NAMA	NO	PERUBAHAN	TANGGAL	NAMA		
				△					

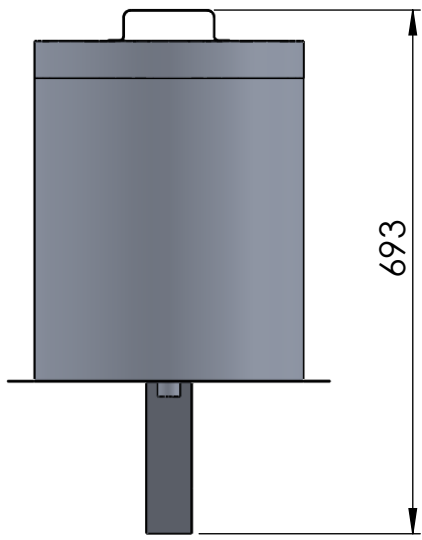
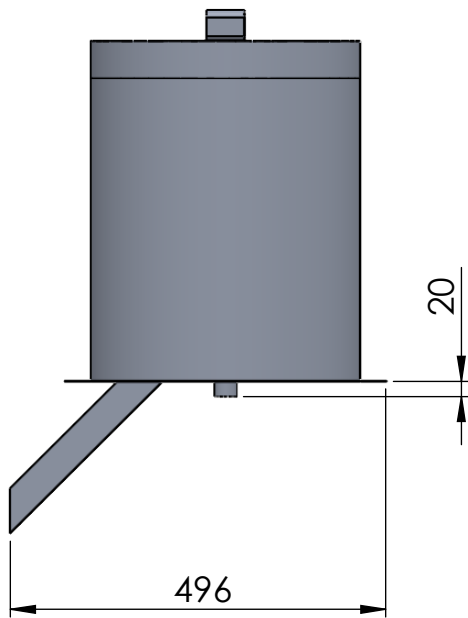
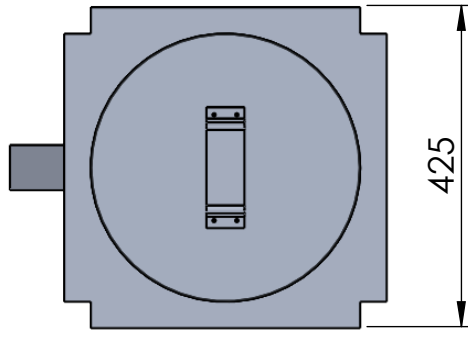

JML	NAMA BAGIAN						POS	BAHAN	UKURAN JADI	UKURAN KASAR	NO. ID	F
>	0	6	30	120	400	1000	PEKERJAAN LANJUT		NO ORDER	PROYEKSI		
<	6	30	120	400	1000	2000						
TOL	±0.1	±0.2	±0.3	±0.5	±0.8	±1.2						
NAMA TABUNG PENAMPUNG									SKALA 1 : 10	DIGAMBAR 06/06/22	REYNALDI	
NO. ASSY :									DIPERIKSA		HILAL	
POLITEKNIK NEGERI CILACAP, JURUSAN TEKNIK MESIN JL. dr. SOETOMO, NO : 01, SIDAKAYA, CILACAP, 53121 TELP. 0282 - 533329, E-mail : tmpnc@politeknikcilacap.ac.id									FORMAT A4	SATUAN mm	MPAT/48	

5		4		3		2		1	
NO	PERUBAHAN	TANGGAL	NAMA	NO	PERUBAHAN	TANGGAL	NAMA		
				△					

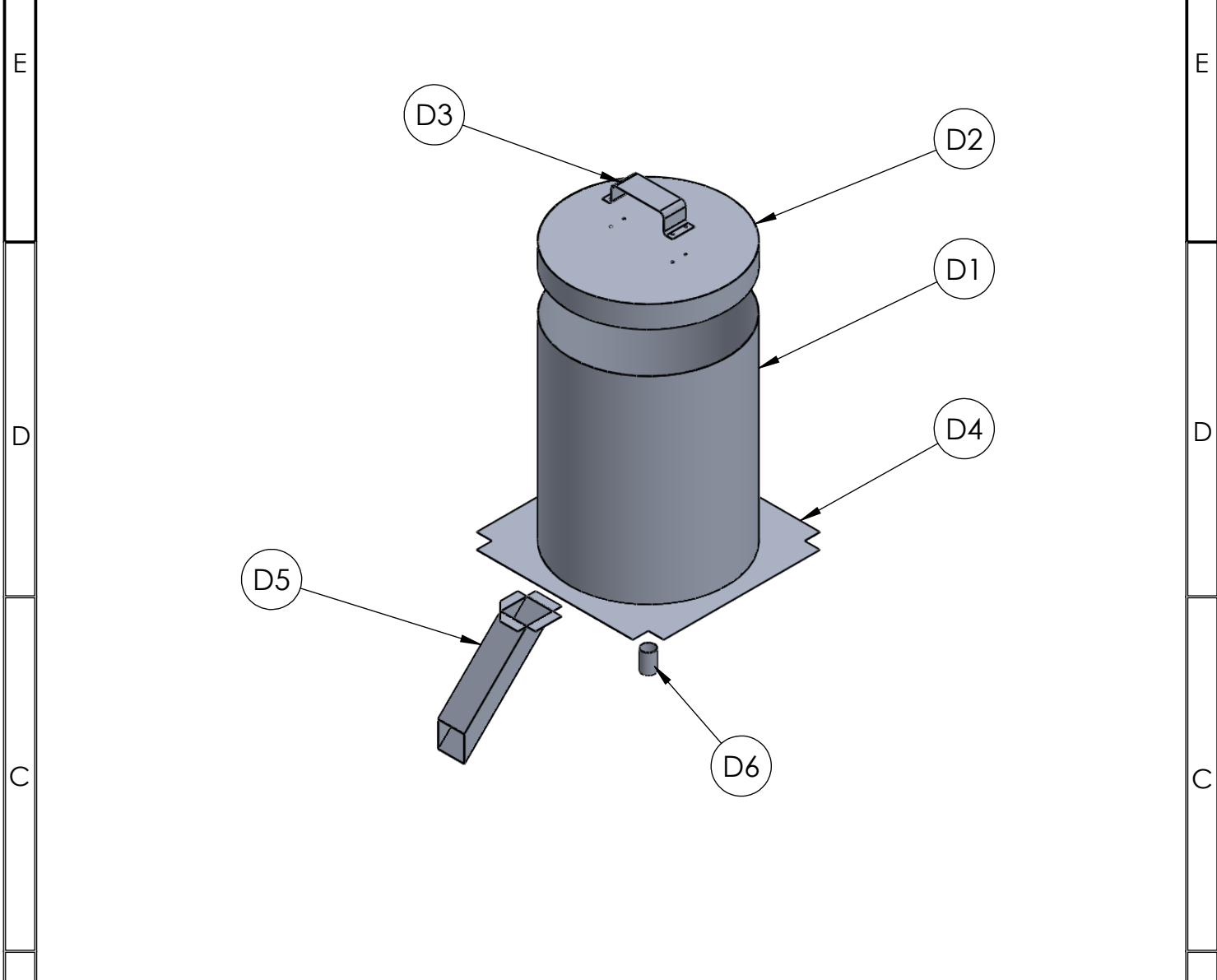

1	TABUNG		ALUMINIUM ALLOY 1100	LIHAT DETAIL		D1	
1	TUTUP		ALUMINIUM ALLOY 1100	LIHAT DETAIL		D2	
1	PEGANGAN		ALUMINIUM ALLOY 1100	LIHAT DETAIL		D3	
1	ALAS		ALUMINIUM ALLOY 1100	LIHAT DETAIL		D4	
1	SALURAN KELUAR		ALUMINIUM ALLOY 1100	LIHAT DETAIL		D5	
1	PENUTUP POROS		ALUMINIUM ALLOY 1100	LIHAT DETAIL		D6	

JML	NAMA BAGIAN					POS	BAHAN	UKURAN JADI	UKURAN KASAR	NO. ID	F
>	0	6	30	120	400	1000	PEKERJAAN LANJUT	NO ORDER	PROYEKSI		
<	6	30	120	400	1000	2000					
TOL	±0.1	±0.2	±0.3	±0.5	±0.8	±1.2					

NAMA								SKALA	DIGAMBAR	06/06/22	REYNALDI
TABUNG PENAMPUNG								1 : 10	DIPERIKSA		HILAL
									DISAHKAN		

NO. ASSY :								FORMAT	SATUAN	MPAT/49	
POLITEKNIK NEGERI CILACAP, JURUSAN TEKNIK MESIN JL. dr. SOETOMO, NO : 01, SIDAKAYA, CILACAP, 53121 TELP. 0282 - 533329, E-mail : tmpnc@politeknikcilacap.ac.id								A4	mm		

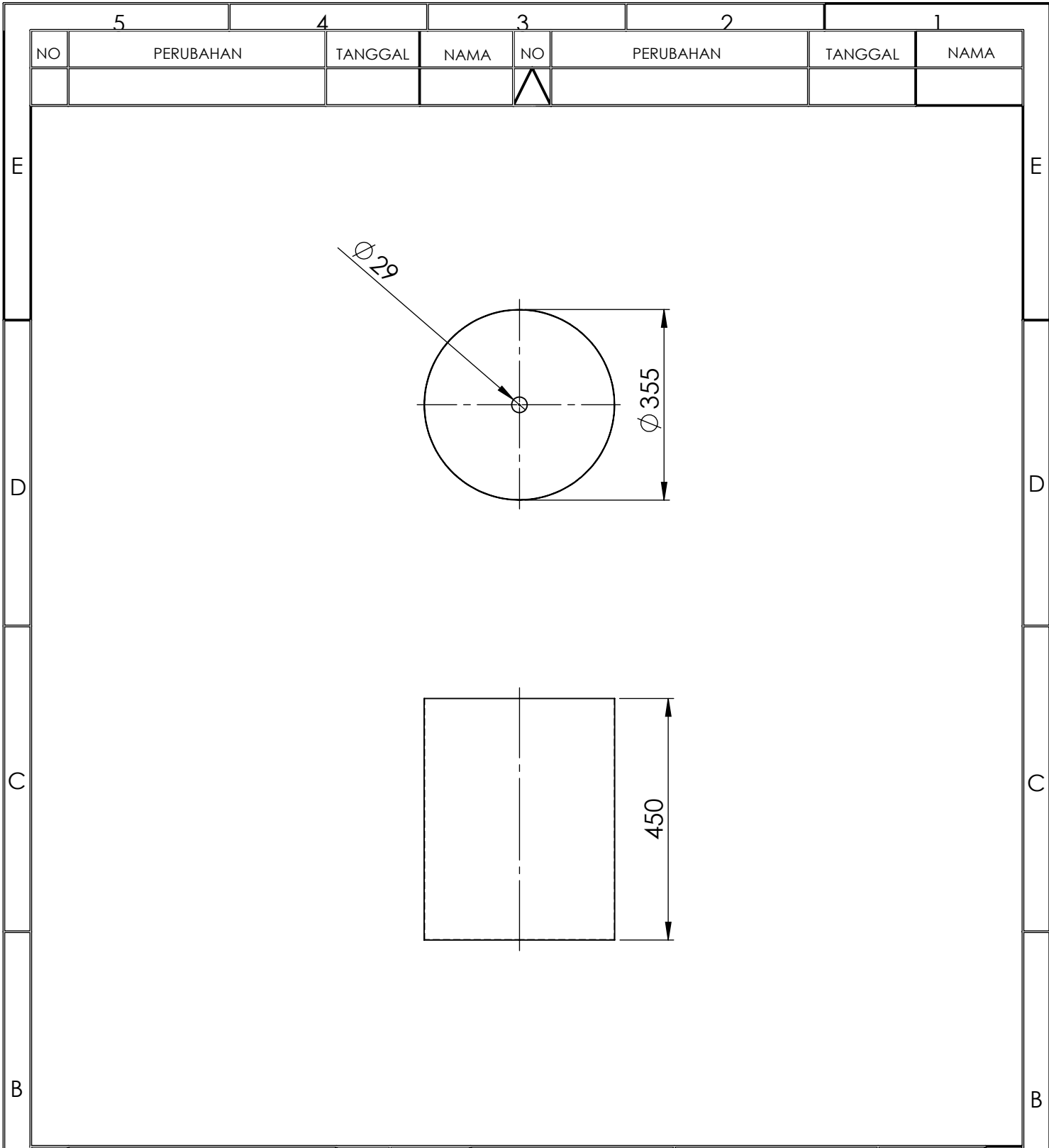

JML	NAMA BAGIAN						POS	BAHAN	UKURAN JADI	UKURAN KASAR	NO. ID	F
>	0	6	30	120	400	1000	PEKERJAAN LANJUT		NO ORDER			
<	6	30	120	400	1000	2000						
TOL	±0.1	±0.2	±0.3	±0.5	±0.8	±1.2						
NAMA TABUNG									SKALA 1 : 10	DIGAMBAR 06/06/22	REYNALDI	A
NO. ASSY :									DIPERIKSA		HILAL	
									DISAHKAN			
POLITEKNIK NEGERI CILACAP, JURUSAN TEKNIK MESIN JL. dr. SOETOMO, NO : 01, SIDAKAYA, CILACAP, 53121 TELP. 0282 - 533329, E-mail : tmpnc@politeknikcilacap.ac.id									FORMAT A4	SATUAN mm	MPAT/50	

5		4		3		2		1	
NO	PERUBAHAN	TANGGAL	NAMA	NO	PERUBAHAN	TANGGAL	NAMA		
				△					

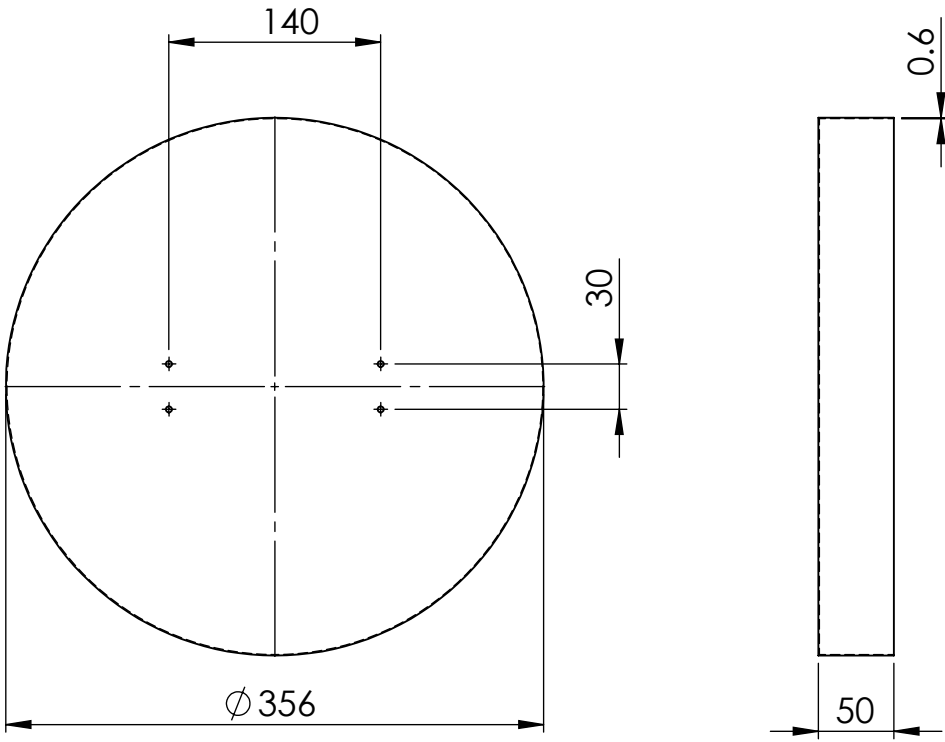

JML	NAMA BAGIAN					POS	BAHAN	UKURAN JADI	UKURAN KASAR	NO. ID	F
>	0	6	30	120	400	1000	PEKERJAAN LANJUT	NO ORDER		REYNALDI	A
<	6	30	120	400	1000	2000					
TOL	±0.1	±0.2	±0.3	±0.5	±0.8	±1.2					
NAMA								SKALA	DIGAMBAR	06/06/22	
TUTUP								1 : 5	DIPERIKSA		HILAL
									DISAHKAN		
NO. ASSY :								FORMAT	SATUAN	MPAT/51	
POLITEKNIK NEGERI CILACAP, JURUSAN TEKNIK MESIN JL. dr. SOETOMO, NO : 01, SIDAKAYA, CILACAP, 53121 TELP. 0282 - 533329, E-mail : tmpnc@politeknikcilacap.ac.id								A4	mm		

5		4			3		2		1	
NO	PERUBAHAN			TANGGAL	NAMA	NO	PERUBAHAN		TANGGAL	NAMA
						△				

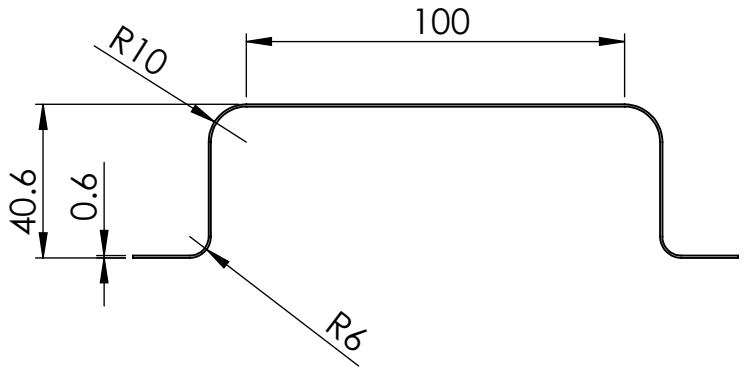
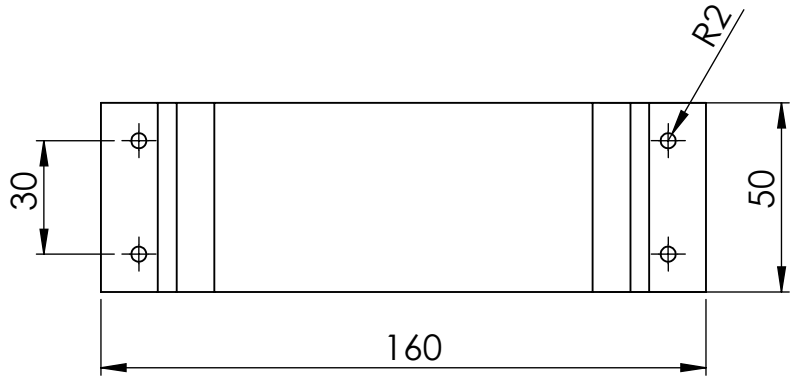

JML	NAMA BAGIAN					POS	BAHAN	UKURAN JADI	UKURAN KASAR	NO. ID	F
>	0	6	30	120	400	1000	PEKERJAAN LANJUT	NO ORDER			
<	6	30	120	400	1000	2000					
TOL	±0.1	±0.2	±0.3	±0.5	±0.8	±1.2					
NAMA								SKALA	DIGAMBAR	06/06/22	REYNALDI
PEGANGAN								1 : 2	DIPERIKSA		HILAL
									DISAHKAN		
NO. ASSY :								FORMAT	SATUAN	MPAT/52	
POLITEKNIK NEGERI CILACAP, JURUSAN TEKNIK MESIN JL. dr. SOETOMO, NO : 01, SIDAKAYA, CILACAP, 53121 Telp. 0282 - 533329, E-mail : tmpnc@politeknikcilacap.ac.id								A4	mm		

PERUBAHAN DARI :

DIGANTI DENGAN :

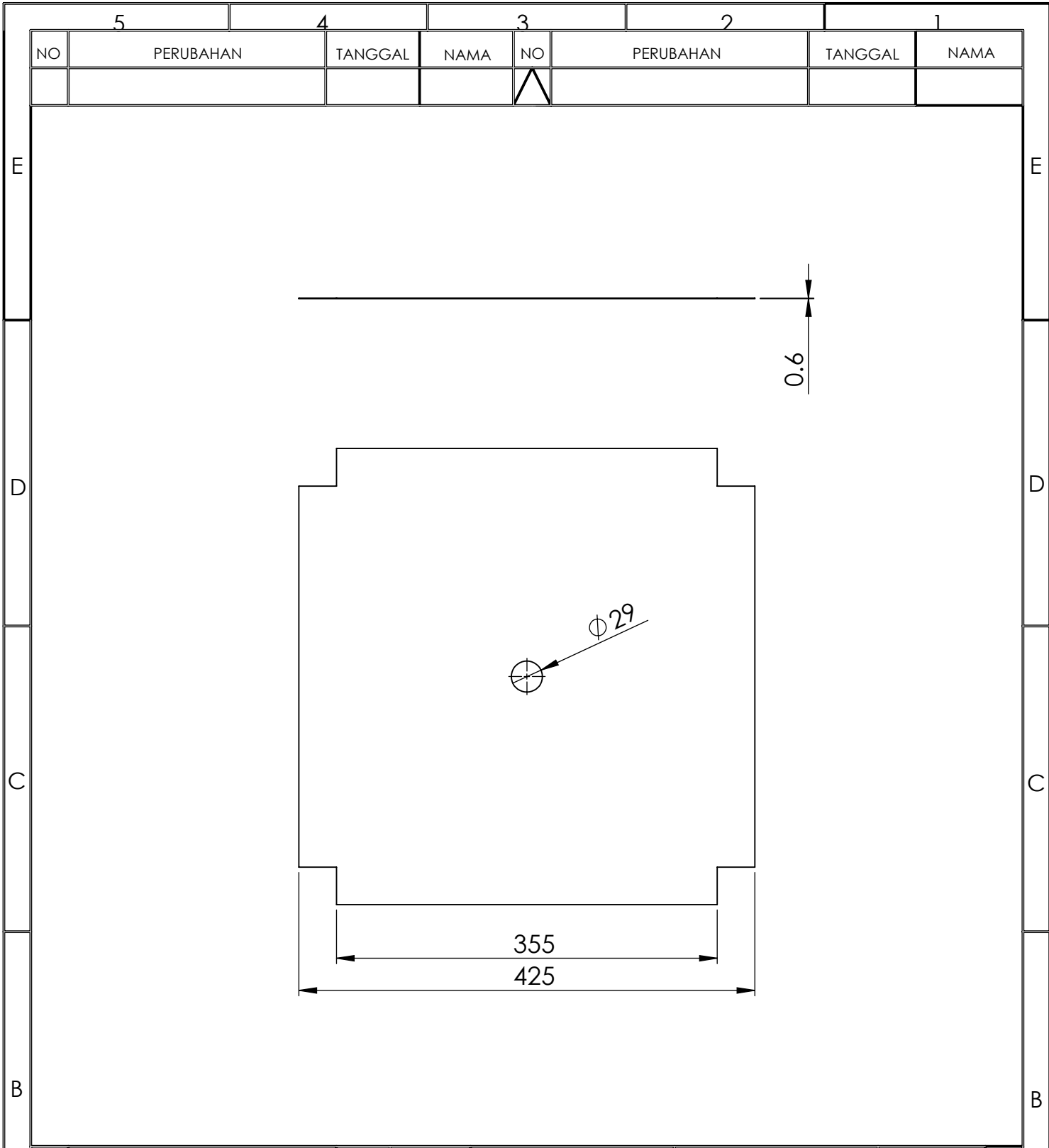

JML	NAMA BAGIAN						POS	BAHAN	UKURAN JADI	UKURAN KASAR	NO. ID	F
>	0	6	30	120	400	1000	PEKERJAAN LANJUT		NO ORDER			
<	6	30	120	400	1000	2000						
TOL	±0.1	±0.2	±0.3	±0.5	±0.8	±1.2						
NAMA ALAS									SKALA 1 : 5	DIGAMBAR 06/06/22	REYNALDI	A
NO. ASSY :									DIPERIKSA		HILAL	
									DISAHKAN			
POLITEKNIK NEGERI CILACAP, JURUSAN TEKNIK MESIN JL. dr. SOETOMO, NO : 01, SIDAKAYA, CILACAP, 53121 TELP. 0282 - 533329, E-mail : tmpnc@politeknikcilacap.ac.id									FORMAT A4	SATUAN mm	MPAT/53	

5		4			3		2		1	
NO	PERUBAHAN	TANGGAL	NAMA	NO	PERUBAHAN	TANGGAL	NAMA			

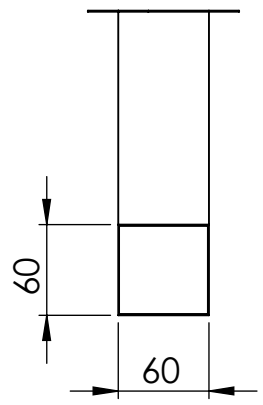
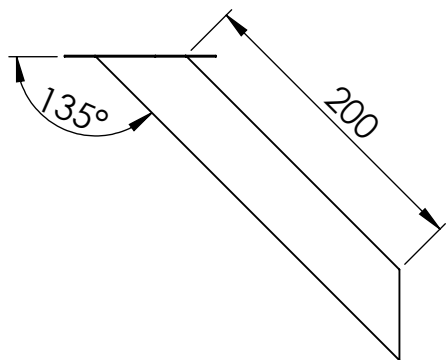
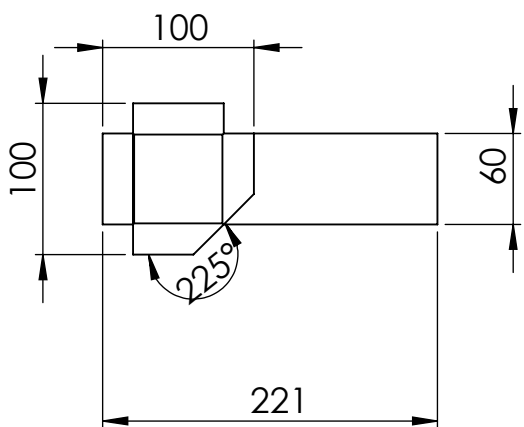

JML	NAMA BAGIAN						POS	BAHAN	UKURAN JADI	UKURAN KASAR	NO. ID	F
>	0	6	30	120	400	1000	PEKERJAAN LANJUT		NO ORDER	PROYEKSI		
<	6	30	120	400	1000	2000						
TOL	±0.1	±0.2	±0.3	±0.5	±0.8	±1.2						
NAMA									SKALA	DIGAMBAR	06/06/22	REYNALDI
SALURAN KELUAR									1 : 5	DIPERIKSA		HILAL
										DISAHKAN		
NO. ASSY :									FORMAT	SATUAN	MPAT/54	
POLITEKNIK NEGERI CILACAP, JURUSAN TEKNIK MESIN JL. dr. SOETOMO, NO : 01, SIDAKAYA, CILACAP, 53121 TELP. 0282 - 533329, E-mail : tmpnc@politeknikcilacap.ac.id									A4	mm		

PERUBAHAN DARI :

DIGANTI DENGAN :

	5	4	3	2	1		
NO	PERUBAHAN	TANGGAL	NAMA	NO	PERUBAHAN	TANGGAL	NAMA
				/			

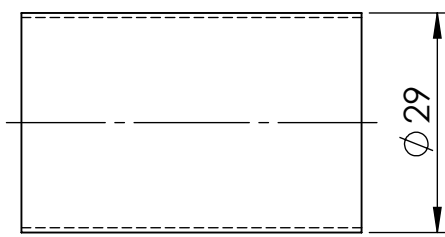
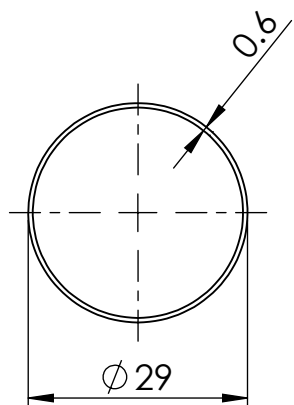

JML	NAMA BAGIAN					POS	BAHAN	UKURAN JADI	UKURAN KASAR	NO. ID	F	
>	0	6	30	120	400	1000	PEKERJAAN LANJUT		NO ORDER		PROYEKSI	
<	6	30	120	400	1000	2000						
TOL	± 0.1	± 0.2	± 0.3	± 0.5	± 0.8	± 1.2						
NAMA PENUTUP POROS								SKALA 1 : 1	DIGAMBAR DIPERIKSA DISAHKAN	06/06/22	REYNALDI HILAL	
NO. ASSY :								FORMAT A4	SATUAN mm	MPAT/55		