

LAMPIRAN 1
Daftar Riwayat Hidup

DAFTAR RIWAYAT HIDUP

Bahwa yang bertanda tangan di bawah ini:

Nama : Rendi Karisma Putra
Jenis Kelamin : Laki-Laki
Tempat, Tanggal Lahir : Semarang, 4 Oktober 2001
Kewarganegaraan : Indonesia
Agama : Islam
Nomor Handphone : 0822-4118-3434
Alamat : Jl. Nusantara RT02/Rw08, Cilacap Utara, Cilacap
Email : rendi.karis04@gmail.com
Motto Hidup : Berani mencoba, menerima tantangan dan lakukan yang terbaik



PENDIDIKAN

- Politeknik Negeri Cilacap (2019 – 2022)
- SMK Negeri 2 Cilacap (2016 – 2019)
- SMP Negeri 6 Cilacap (2013 – 2016)
- SD Negeri Sidanegara 09 (2007 – 2013)

PENGALAMAN ORGANISASI

- 2020-2021 : Badan Eksekutif Mahasiswa PNC (Sekretaris Jenderal)
- 2020-2021 : UKM Tae Kwon Do PNC (Penanggungjawab)
- 2020-2021 : UKM Merpati Putih (Koordinator Humas)
- 2019-2020 : Badan Eksekutif Mahasiswa PNC (Deputi Persidangan)
- 2019-2020 : UKM Tae Kwon Do (Ketua)
- 2019-2020 : UKM Merpati Putih (Kominfo)

Demikian daftar riwayat hidup ini saya buat dengan sebenarnya.

Saya yang bersangkutan,

(Rendi Karisma Putra)

LAMPIRAN 2

Tabel 1-35 (*Design Manual Timing Belt*, hal. 26)

Table 1-35

Nominal length	Number of teeth	Pitch length(mm)	Manufacturable Size	
			GB	U
S2M 184	92	184	S	
S2M 186	93	186	S	
S2M 188	94	188	S	
S2M 190	95	190	S	S
S2M 192	96	192	S	
S2M 194	97	194	S	S
S2M 196	98	196	S	
S2M 198	99	198	S	
S2M 200	100	200	S	S
S2M 202	101	202	S	
S2M 204	102	204	S	
S2M 206	103	206	S	
S2M 208	104	208	S	
S2M 210	105	210	S	S
S2M 212	106	212	S	S
S2M 214	107	214	S	
S2M 216	108	216	S	
S2M 218	109	218		S
S2M 220	110	220	S	S
S2M 224	112	224	S	S
S2M 226	113	226	S	
S2M 230	115	230	S	S
S2M 232	116	232	S	
S2M 234	117	234	S	
S2M 236	118	236	S	S
S2M 238	119	238	S	
S2M 240	120	240	S	S
S2M 242	121	242		S
S2M 244	122	244	S	S
S2M 246	123	246	S	S
S2M 248	124	248	S	
S2M 250	125	250	S	S
S2M 252	126	252	S	
S2M 254	127	254	S	
S2M 256	128	256	S	
S2M 258	129	258	S	
S2M 260	130	260	S	S
S2M 262	131	262	S	
S2M 264	132	264	S	
S2M 266	133	266	S	
S2M 268	134	268	S	
S2M 270	135	270	S	
S2M 272	136	272	S	
S2M 276	138	276	S	
S2M 278	139	278	S	
S2M 280	140	280	S	S
S2M 284	142	284	S	
S2M 286	143	286	S	
S2M 288	144	288	S	
S2M 290	145	290	S	S

LAMPIRAN 3

Tabel 1-95 (*Design Manual Timing Belt*, hal. 47)

Table 1-95

Tooth Profile		MXL-Rod shape			
No. of teeth	Length (mm)	Material	OD (mm)	PD (mm)	Product Code
10	100	High-Strength Aluminum Alloy	5.96	6.47	P10 MXL 100
12			7.25	7.76	P12 MXL 100
13			7.90	8.41	P13 MXL 100
14			8.55	9.06	P14 MXL 100
15			9.19	9.70	P15 MXL 100
16			9.84	10.35	P16 MXL 100
17			10.49	11.00	P17 MXL 100
18			11.13	11.64	P18 MXL 100
19			11.78	12.29	P19 MXL 100
20			12.43	12.94	P20 MXL 100
21			13.07	13.58	P21 MXL 100
22			13.72	14.23	P22 MXL 100
23			14.37	14.88	P23 MXL 100
24			15.02	15.52	P24 MXL 100
25			15.66	16.17	P25 MXL 100
26			16.31	16.82	P26 MXL 100
27			16.96	17.46	P27 MXL 100
28			17.60	18.11	P28 MXL 100
30			18.90	19.40	P30 MXL 100
32			20.19	20.70	P32 MXL 100
34			21.48	21.99	P34 MXL 100
36			22.78	23.29	P36 MXL 100
38			24.07	24.58	P38 MXL 100
40			25.36	25.87	P40 MXL 100
42			26.66	27.17	P42 MXL 100
44			27.95	28.46	P44 MXL 100
48			30.54	31.05	P48 MXL 100
50			31.83	32.34	P50 MXL 100
52			33.13	33.63	P52 MXL 100
54			34.42	34.93	P54 MXL 100
56			35.71	36.22	P56 MXL 100
60			38.30	38.81	P60 MXL 100
64	40.89	41.40	P64 MXL 100		
70	44.77	45.28	P70 MXL 100		
72	46.06	46.57	P72 MXL 100		
80	51.24	51.74	P80 MXL 100		
84	53.82	54.33	P84 MXL 100		
96	61.59	62.09	P96 MXL 100		
100	64.17	64.68	P100 MXL 100		
120	77.11	77.62	P120 MXL 100		

LAMPIRAN 4

**Tabel Jenis Turbin Air dan Kisaran Kecepatan
(Luknanto, D, hal. 1-7)**

Jenis Turbin		N_s (metrik)
1. Turbin Impuls	a. Satu jet (turbin Pelton)	4–30
	b. Banyak jet (turbin Doble)	30–70
2. Turbin Reaksi	a. Francis	50–125
	N_s rendah	125–200
	N_s normal	200–350
	N_s tinggi	350–500
	N_s express	
	b. Propeller	
	Sudu tetap (turbin Nagler)	400–800
	Sudu dapat diatur (turbin Kaplan)	500–1000

LAMPIRAN 5

Tabel Spesifikasi Bantalan (Sularso, hal.143)

Nomor Bantalan	Diameter Dalam	Diameter Luar	Kapasitas Nominal Dinamis Spesifik C (kg)
6000	10	26	360
6001	12	28	400
6002	15	32	440
6003	17	35	470
6004	20	40	735

LAMPIRAN 6

Tabel Rekomendasi nilai K_m dan K_t

(*Machine Design*, hal. 531)

<i>Nature of load</i>	K_m	K_f
1. Stationary shafts		
(a) Gradually applied load	1.0	1.0
(b) Suddenly applied load	1.5 to 2.0	1.5 to 2.0
2. Rotating shafts		
(a) Gradually applied or steady load	1.5	1.0
(b) Suddenly applied load with minor shocks only	1.5 to 2.0	1.5 to 2.0
(c) Suddenly applied load with heavy shocks	2.0 to 3.0	1.5 to 3.0

LAMPIRAN 7

Assembly Purwarupa PLTPH

4		3		2		1	
No.	Perubahan	Tanggal	Nama	No.	Perubahan	Tanggal	Nama
△				△			

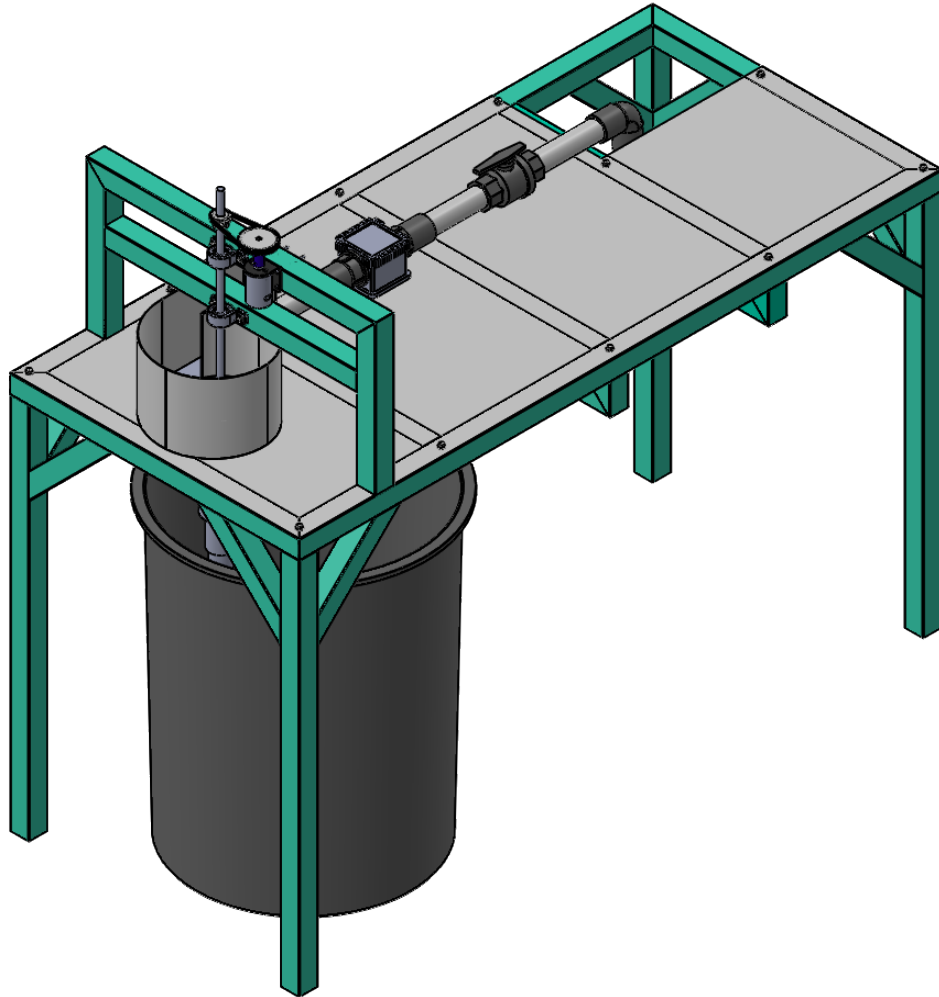

1	Assembly Purwarupa PLTPH						-	Lihat Detail	Lihat Detail	Dibuat
Jml	Nama Bagian						No.Id	Bahan	Ukuran	Keterangan
>	0	6	30	120	400	1000	Ukuran Lanjut:	No. Order:	Proyeksi:	
<	6	30	120	400	1000	2000				
Tol	±0.1	±0.2	±0.3	±0.5	±0.8	±1.2				

Nama:

ASSEMBLY PURWARUPA PLTPH

No. Assy:

Skala 1:10	Digambar	1-8-22	Rendi
	Diperiksa		Radhi
	Disahkan		Bayu



Politeknik Negeri Cilacap, Jurusan Teknik Mesin
 Jl. Dr. Soetomo, No. 01, Sidakaya, Cilacap, 53212
 Telp: 0282-533329, E-mail: tmpnc@politeknikcilacap.ac.id

Format
A4

Satuan
mm

4		3		2		1	
No.	Perubahan	Tanggal	Nama	No.	Perubahan	Tanggal	Nama
△				△			

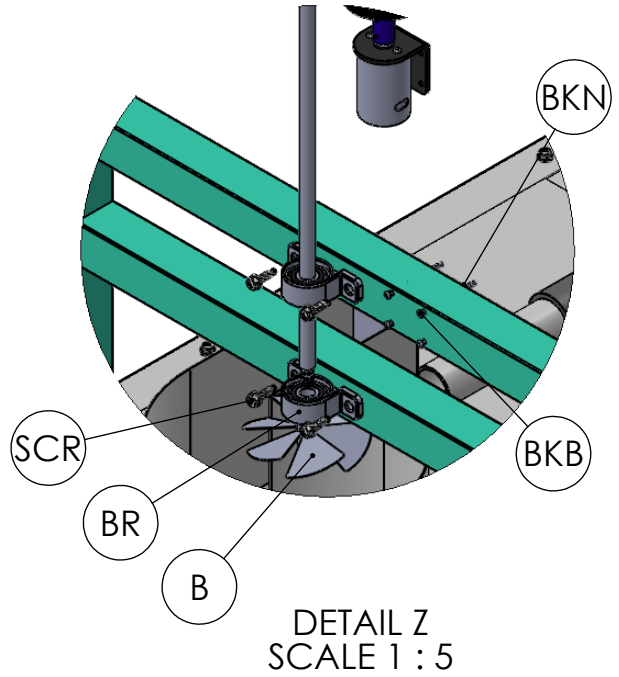
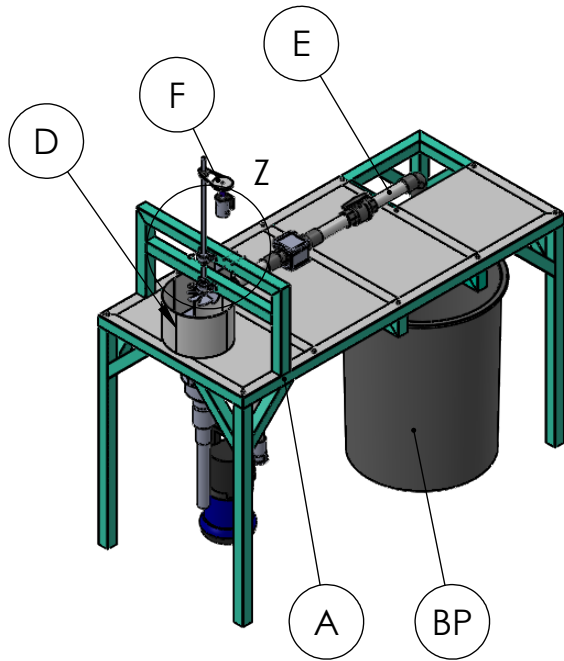

1	Submersible Pump	SP	Lihat Detail	Lihat Detail	Dibeli
19	Screw M5	SCR	Lihat Detail	Lihat Detail	Dibeli
2	Clamp Pipe	CP	Lihat Detail	Lihat Detail	Dibeli
4	Bracket Nut	BKN	Lihat Detail	Lihat Detail	Dibeli
4	Bracket Bolt	BKB	Lihat Detail	Lihat Detail	Dibeli
1	Bak Penampungan Air	BPA	Lihat Detail	Lihat Detail	Dibeli
2	Bearing	BR	Lihat Detail	Lihat Detail	Dibeli
1	Transmission	F	Lihat Detail	Lihat Detail	Dibeli
1	Penstock	E	Lihat Detail	Lihat Detail	Dibuat
1	Spiral Casing	D	Lihat Detail	Lihat Detail	Dibuat
1	Guide Vanes	C	Lihat Detail	Lihat Detail	Dibuat
1	Runner	B	Lihat Detail	Lihat Detail	Dibuat
1	Kerangka	A	Lihat Detail	Lihat Detail	Dibuat

B	Jml	Nama Bagian					No.Id	Bahan	Ukuran	Keterangan
	>	0	6	30	120	400	1000	Ukuran Lanjut:	No. Order:	Proyeksi:
	<	6	30	120	400	1000	2000			
	Tol	±0.1	±0.2	±0.3	±0.5	±0.8	±1.2			

Nama:				Skala 1:20	Digambar	1-8-22	Rendi
EXPLODE SUB ASSEMBLY					Diperiksa		Radhi
					Disahkan		Bayu
No. Assy:				Format A4	Satuan		
 Politeknik Negeri Cilacap, Jurusan Teknik Mesin Jl. Dr. Soetomo, No. 01, Sidakaya, Cilacap, 53212 Telp: 0282-533329, E-mail: tmpnc@politeknikcilacap.ac.id					mm		

DILARANG MENGGANDAKAN, MENYALIN, MEMINDAHTANGANKAN GAMBAR INI TANPA IZIN TERTULIS DARI POLITEKNIK NEGERI CILACAP

4		3		2		1	
No.	Perubahan	Tanggal	Nama	No.	Perubahan	Tanggal	Nama
△				△			

F

E

D

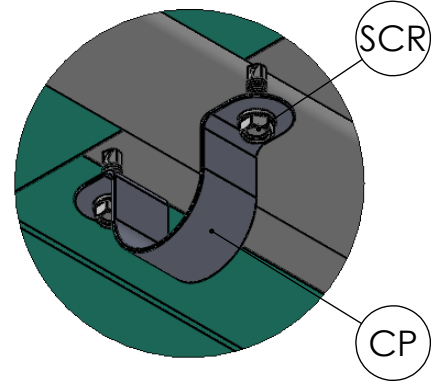
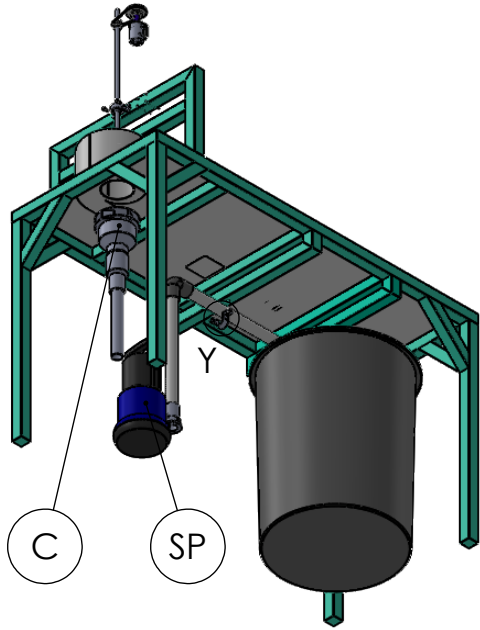

DETAIL Y
SCALE 1 : 2

1	Submersible Pump	SP	Lihat Detail	Lihat Detail	Dibeli
19	Screw M5	SCR	Lihat Detail	Lihat Detail	Dibeli
2	Clamp Pipe	CP	Lihat Detail	Lihat Detail	Dibeli
4	Bracket Nut	BKN	Lihat Detail	Lihat Detail	Dibeli
4	Bracket Bolt	BKB	Lihat Detail	Lihat Detail	Dibeli
1	Bak Penampungan Air	BPA	Lihat Detail	Lihat Detail	Dibeli
2	Bearing	BR	Lihat Detail	Lihat Detail	Dibeli
1	Transmission	F	Lihat Detail	Lihat Detail	Dibeli
1	Penstock	E	Lihat Detail	Lihat Detail	Dibuat
1	Spiral Casing	D	Lihat Detail	Lihat Detail	Dibuat
1	Guide Vanes	C	Lihat Detail	Lihat Detail	Dibuat
1	Runner	B	Lihat Detail	Lihat Detail	Dibuat
1	Kerangka	A	Lihat Detail	Lihat Detail	Dibuat

C

B

Jml	Nama Bagian						No.Id	Bahan	Ukuran	Keterangan
>	0	6	30	120	400	1000	Ukuran Lanjut:	No. Order:	Proyeksi:	
<	6	30	120	400	1000	2000				
Tol	±0.1	±0.2	±0.3	±0.5	±0.8	±1.2				

A

Nama:

EXPLODE SUB ASSEMBLY PLTPH

No. Assy:

Skala 1:20	Digambar	1-8-22	Rendi
	Diperiksa		Radhi
	Disahkan		Bayu

Politeknik Negeri Cilacap, Jurusan Teknik Mesin
 Jl. Dr. Soetomo, No. 01, Sidakaya, Cilacap, 53212
 Telp: 0282-533329, E-mail: tmpnc@politeknikcilacap.ac.id

Format
A4

Satuan
mm

DILARANG MENGGANDAKAN, MENYALIN, MEMINDAHTANGANKAN GAMBAR INI TANPA IZIN TERTULIS DARI POLITEKNIK NEGERI CILACAP

4

3

2

1

F

E

D

C

B

A

LAMPIRAN 8

Kerangka

4

3

2

1

No.	Perubahan	Tanggal	Nama	No.	Perubahan	Tanggal	Nama
△				△			

F

F

E

E

D

D

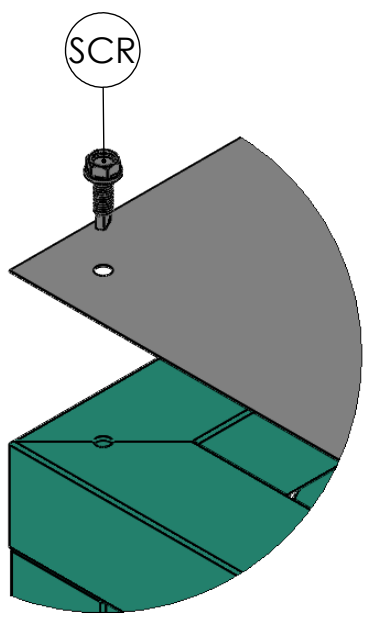

DETAIL U
SCALE 1 : 2

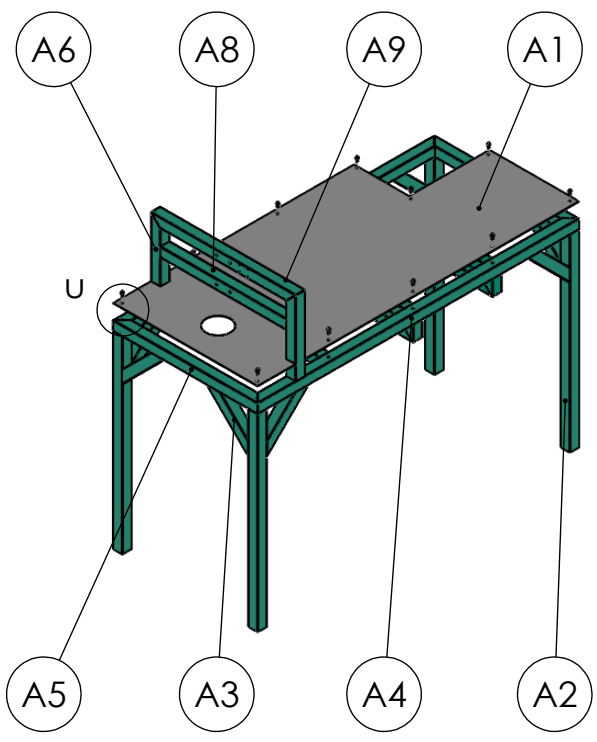

4	Dudukan Clamp Pipa 2	A11	Galvanis	Lihat Detail	Dibuat
2	Dudukan Clamp Pipa 1	A10	Galvanis	Lihat Detail	Dibuat
1	Dudukan Bantalan 2	A9	Galvanis	Lihat Detail	Dibuat
1	Dudukan Bantalan 1	A8	Galvanis	Lihat Detail	Dibuat
3	Palang Penguat Meja	A7	Galvanis	Lihat Detail	Dibuat
2	Penyangga Transmisi	A6	Galvanis	Lihat Detail	Dibuat
2	Rusuk Meja 2	A5	Galvanis	Lihat Detail	Dibuat
2	Rusuk Meja 1	A4	Galvanis	Lihat Detail	Dibuat
8	Penguat Meja 45°	A3	Galvanis	Lihat Detail	Dibuat
4	Kaki Meja	A2	Galvanis	Lihat Detail	Dibuat
1	Daun Meja	A1	Stainless 304	Lihat Detail	Dibuat
11	Screw M5	SCR	Mild Steel	Lihat Detail	Dibeli
Jml	Nama Bagian	No.Id	Bahan	Ukuran	Keterangan

>	0	6	30	120	400	1000	Ukuran Lanjut:	No. Order:	Proyeksi:
<	6	30	120	400	1000	2000			
Tol	±0.1	±0.2	±0.3	±0.5	±0.8	±1.2			

Nama:				Skala 1:20	Digambar	1-8-22	Rendi
SUB ASSEMBLY KERANGKA					Diperiksa		Radhi
					Disahkan		Bayu
No. Assy:							

 Politeknik Negeri Cilacap, Jurusan Teknik Mesin Jl. Dr. Soetomo, No. 01, Sidakaya, Cilacap, 53212 Telp: 0282-533329, E-mail: tmpnc@politeknikcilacap.ac.id				Format A4	Satuan mm		
---	--	--	--	--------------	--------------	--	--

DILARANG MENGGANDAKAN, MENYALIN, MEMINDAHTANGKAN GAMBAR INI TANPA IZIN TERTULIS DARI POLITEKNIK NEGERI CILACAP

4

3

2

1

A

A

No.	Perubahan	Tanggal	Nama	No.	Perubahan	Tanggal	Nama
△				△			

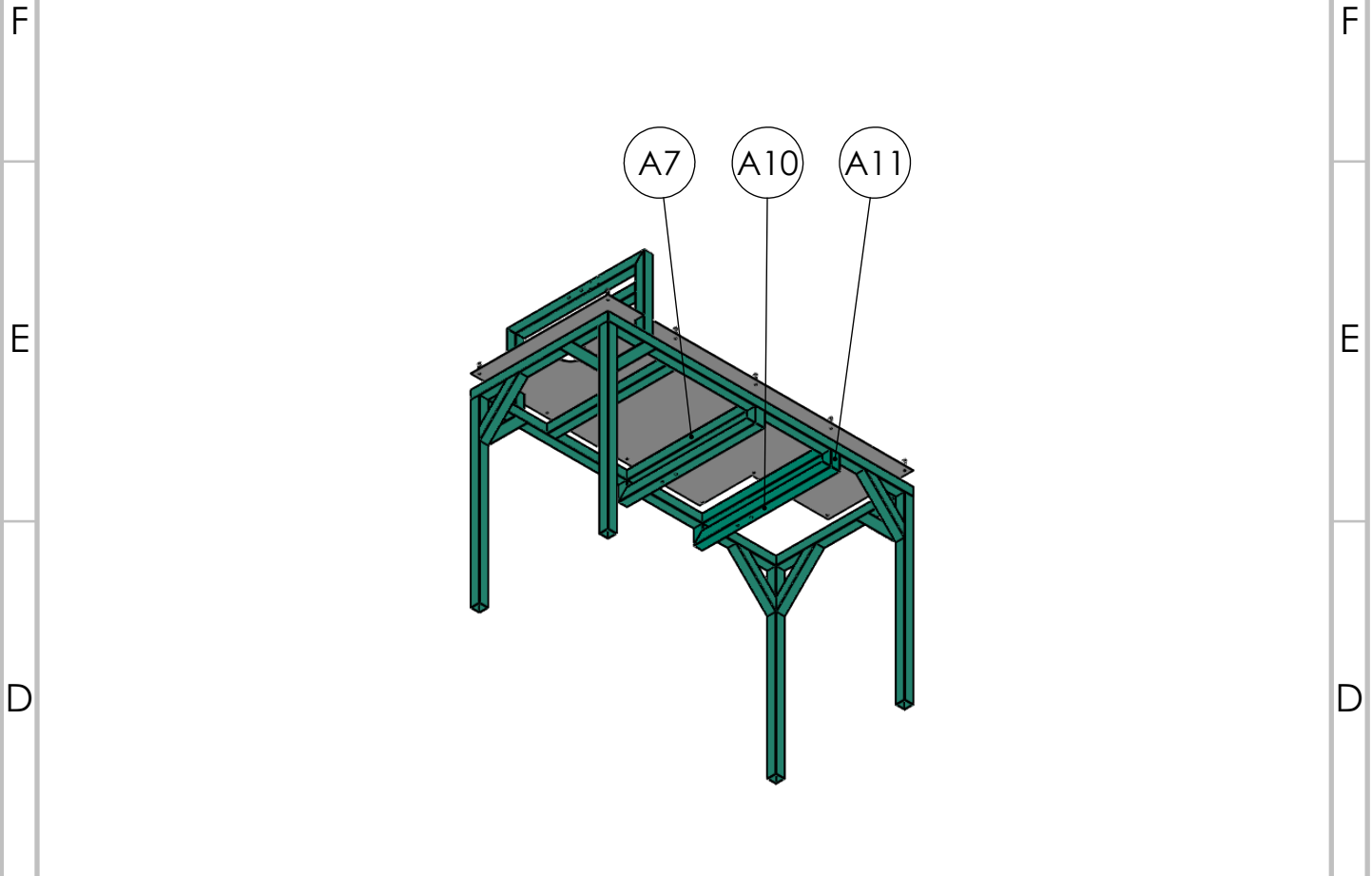

4	Dudukan Clamp Pipa 2					A11	Galvanis	Lihat Detail	Dibuat
2	Dudukan Clamp Pipa 1					A10	Galvanis	Lihat Detail	Dibuat
1	Dudukan Bantalan 2					A9	Galvanis	Lihat Detail	Dibuat
1	Dudukan Bantalan 1					A8	Galvanis	Lihat Detail	Dibuat
3	Palang Penguat Meja					A7	Galvanis	Lihat Detail	Dibuat
2	Penyangga Transmisi					A6	Galvanis	Lihat Detail	Dibuat
2	Rusuk Meja 2					A5	Galvanis	Lihat Detail	Dibuat
2	Rusuk Meja 1					A4	Galvanis	Lihat Detail	Dibuat
8	Penguat Meja 45°					A3	Galvanis	Lihat Detail	Dibuat
4	Kaki Meja					A2	Galvanis	Lihat Detail	Dibuat
1	Daun Meja					A1	Stainless 330	Lihat Detail	Dibuat
11	Screw M5					SCR	Mild Steel	Lihat Detail	Dibeli
Jml	Nama Bagian					No.Id	Bahan	Ukuran	Keterangan
>	0	6	30	120	400	1000	Ukuran Lanjut:	No. Order:	Proyeksi:
<	6	30	120	400	1000	2000			
Tol	±0.1	±0.2	±0.3	±0.5	±0.8	±1.2			

Nama:	Skala 1:20	Digambar	1-8-22	Rendi
SUB ASSEMBLY KERANGKA		Diperiksa		Radhi
		Disahkan		Bayu
No. Assy:	Format A4	Satuan mm		

DILARANG MENGGANDAKAN, MENYALIN, MEMINDAHKANGANKAN GAMBAR INI
TANPA IZIN TERTULIS DARI POLITEKNIK NEGERI CILACAP

4		3		2		1	
No.	Perubahan	Tanggal	Nama	No.	Perubahan	Tanggal	Nama
△				△			

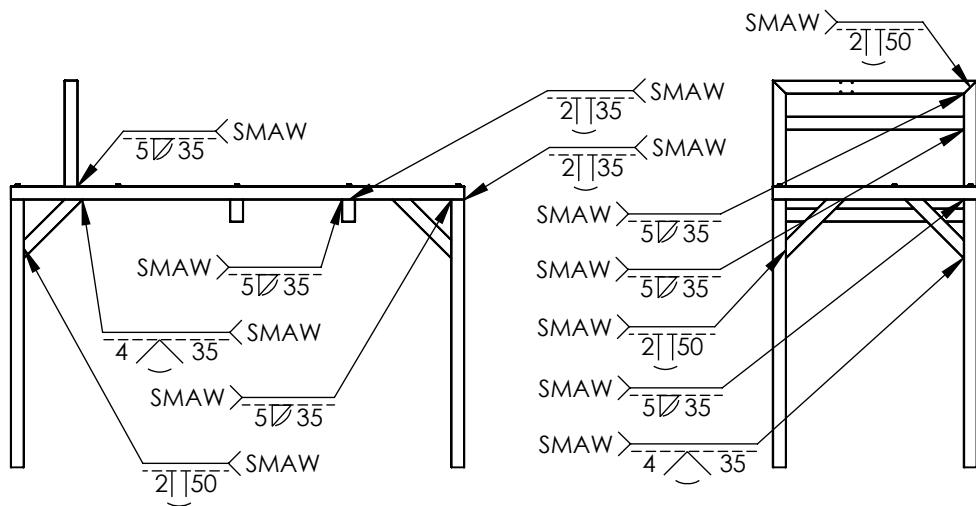
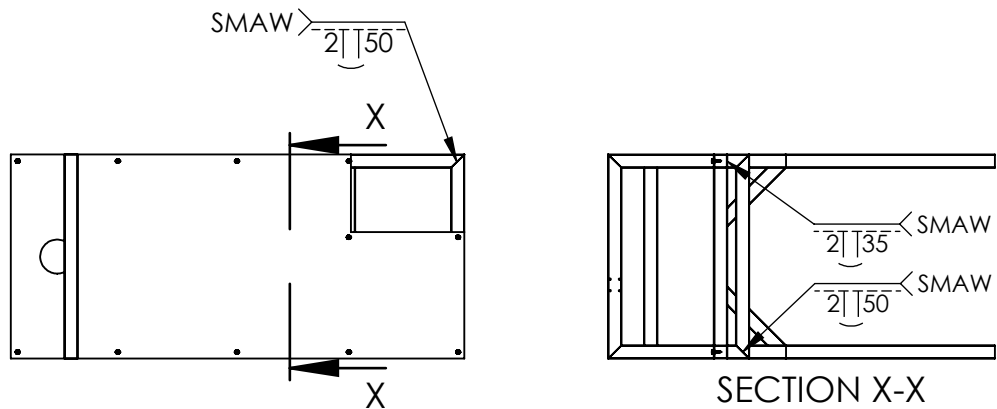

1	Kerangka						A	Lihat Detail	Lihat Detail	Dibuat		
B	Jml	Nama Bagian					No.Id	Bahan	Ukuran	Keterangan		
	>	0	6	30	120	400	1000	Ukuran Lanjut:	No. Order:	Proyeksi:		
	<	6	30	120	400	1000	2000					
	Tol	±0.1	±0.2	±0.3	±0.5	±0.8	±1.2					
A	Nama: <h2 style="text-align: center;">SUB ASSEMBLY KERANGKA</h2> No. Assy:								Skala 1:20	Digambar	1-8-22	Rendi
								Diperiksa			Radhi	
								Disahkan			Bayu	
								Format	Satuan			
								A4	mm			



Politeknik Negeri Cilacap, Jurusan Teknik Mesin
 Jl. Dr. Soetomo, No. 01, Sidakaya, Cilacap, 53212
 Telp: 0282-533329, E-mail: tmpnc@politeknikcilacap.ac.id

DILARANG MENGGANDAKAN, MENYALIN, MEMINDAHTANGANKAN GAMBAR INI
TANPA IZIN TERTULIS DARI POLITEKNIK NEGERI CILACAP

4		3		2		1	
No.	Perubahan	Tanggal	Nama	No.	Perubahan	Tanggal	Nama
△				△			

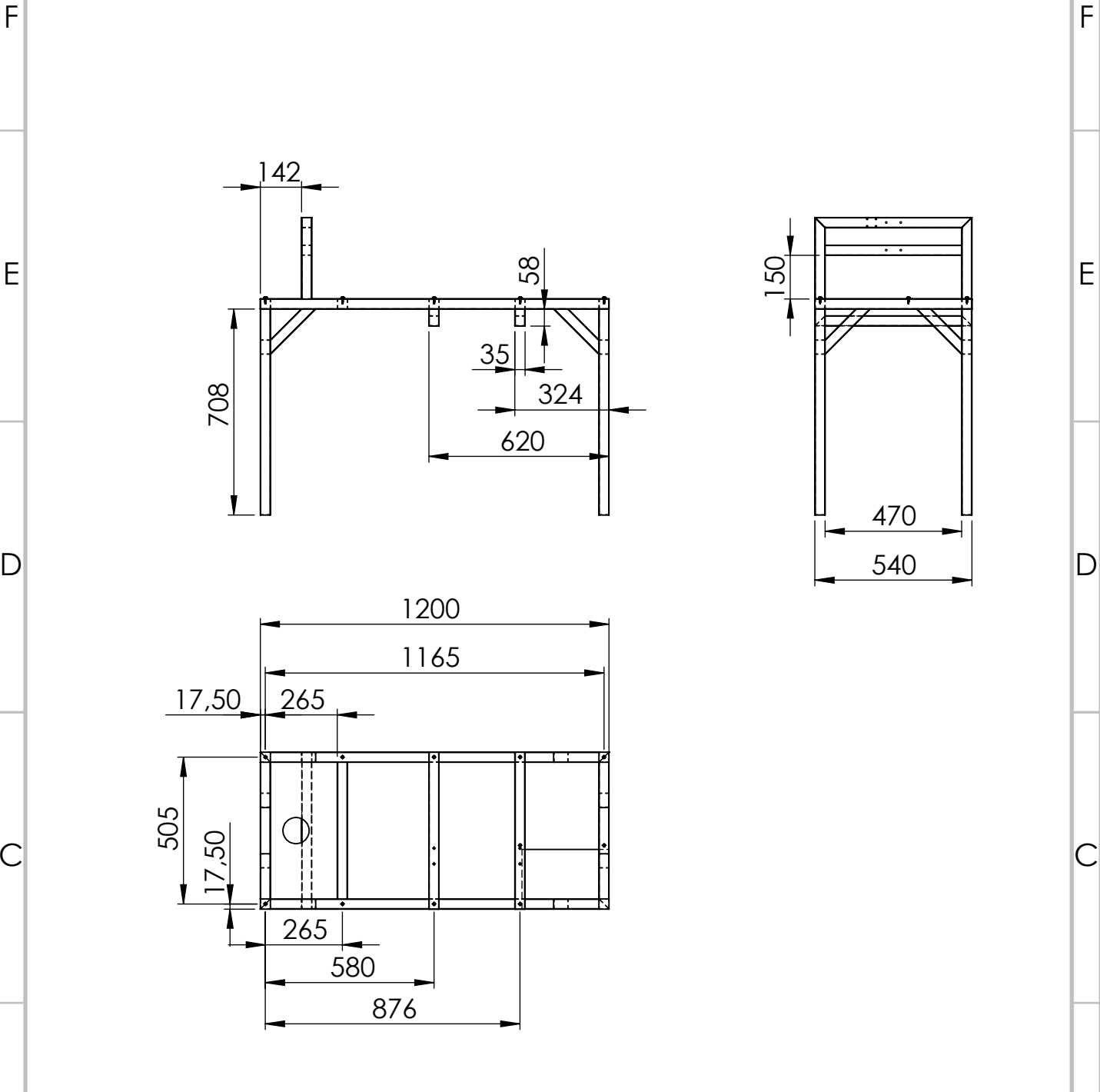

1	Kerangka						A	Lihat Detail	Lihat Detail	Dibuat
B	Jml	Nama Bagian					No.Id	Bahan	Ukuran	Keterangan
	>	0	6	30	120	400	1000	Ukuran Lanjut:	No. Order:	Proyeksi:
	<	6	30	120	400	1000	2000			
	Tol	±0.1	±0.2	±0.3	±0.5	±0.8	±1.2			

A	Nama:	Skala 1:20	Digambar	1-8-22	Rendi
	SUB ASSEMBLY KERANGKA		Diperiksa		Radhi
			Disahkan		Bayu
No. Assy:		Format A4	Satuan mm		

4		3		2		1	
No.	Perubahan	Tanggal	Nama	No.	Perubahan	Tanggal	Nama
△				△			

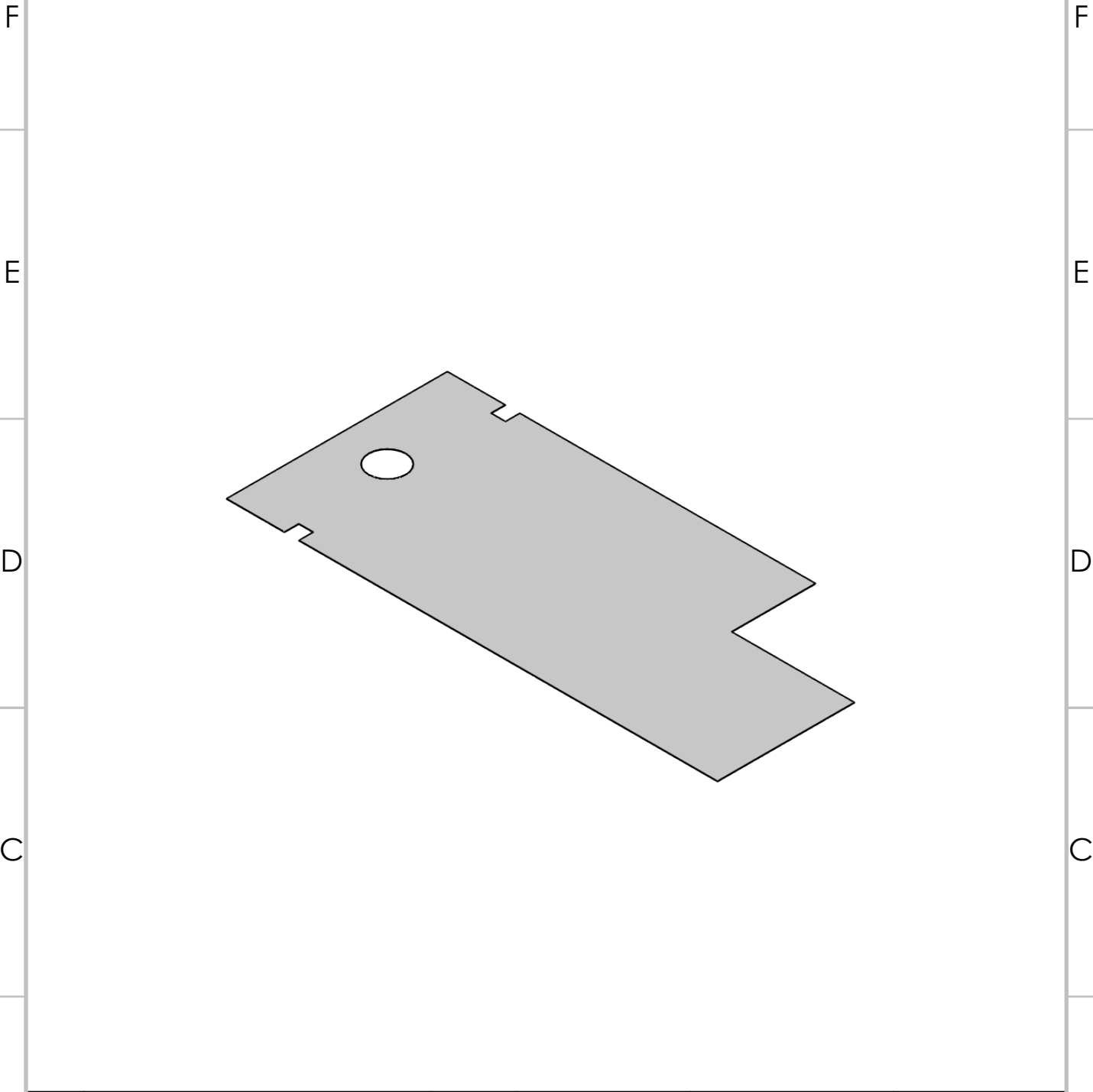

1	Daun Meja						A1	Stainless 430	Lihat Detail	Dibuat		
B	Jml Nama Bagian						No.Id	Bahan	Ukuran	Keterangan		
	>	0	6	30	120	400	1000	Ukuran Lanjut:	No. Order:	Proyeksi:		
	<	6	30	120	400	1000	2000					
	Tol	+0.1	+0.2	+0.3	+0.5	+0.8	+1.2					
A	Nama: DAUN MEJA								Skala 1:10	Digambar	1-8-22	Rendi
	No. Assy:									Diperiksa		Radhi
										Disahkan		Bayu
	Politeknik Negeri Cilacap, Jurusan Teknik Mesin Jl. Dr. Soetomo, No. 01, Sidakaya, Cilacap, 53212 Telp: 0282-533329, E-mail: tmpnc@politeknikcilacap.ac.id								Format A4	Satuan mm		

DILARANG MENGGANDAKAN, MENYALIN, MEMINDAHKAN GAMBAR INI TANPA IZIN TERTULIS DARI POLITEKNIK NEGERI CILACAP

4		3		2		1	
No.	Perubahan	Tanggal	Nama	No.	Perubahan	Tanggal	Nama
△				△			

F
E
D
C
B
A

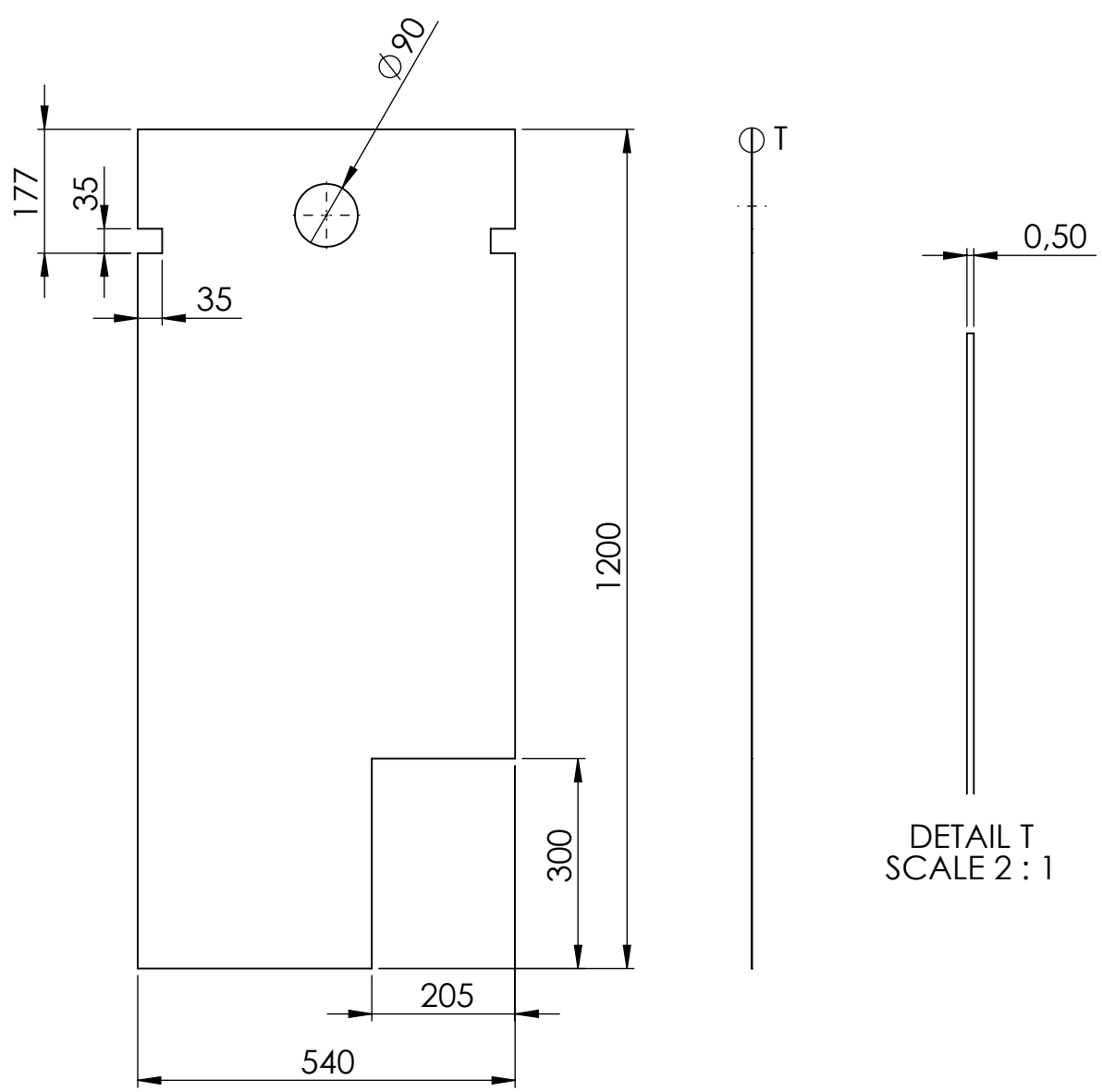

1	Daun Meja						A1	Stainless 430	Lihat Detail	Dibuat		
B	Jml	Nama Bagian					No.Id	Bahan	Ukuran	Keterangan		
	>	0	6	30	120	400	1000	Ukuran Lanjut:	No. Order:	Proyeksi:		
	<	6	30	120	400	1000	2000					
	Tol	±0.1	±0.2	±0.3	±0.5	±0.8	±1.2					
A	Nama: <h2 style="text-align: center;">DAUN MEJA</h2> No. Assy:								Skala 1:10	Digambar	1-8-22	Rendi
								Diperiksa			Radhi	
								Disahkan			Bayu	
								Format A4	Satuan mm			

DILARANG MENGGANDAKAN, MENYALIN, MEMINDAH TANGKAPAN GAMBAR INI
TANPA IZIN TERTULIS DARI POLITEKNIK NEGERI CILACAP

4		3			2		1
No.	Perubahan	Tanggal	Nama	No.	Perubahan	Tanggal	Nama
△				△			

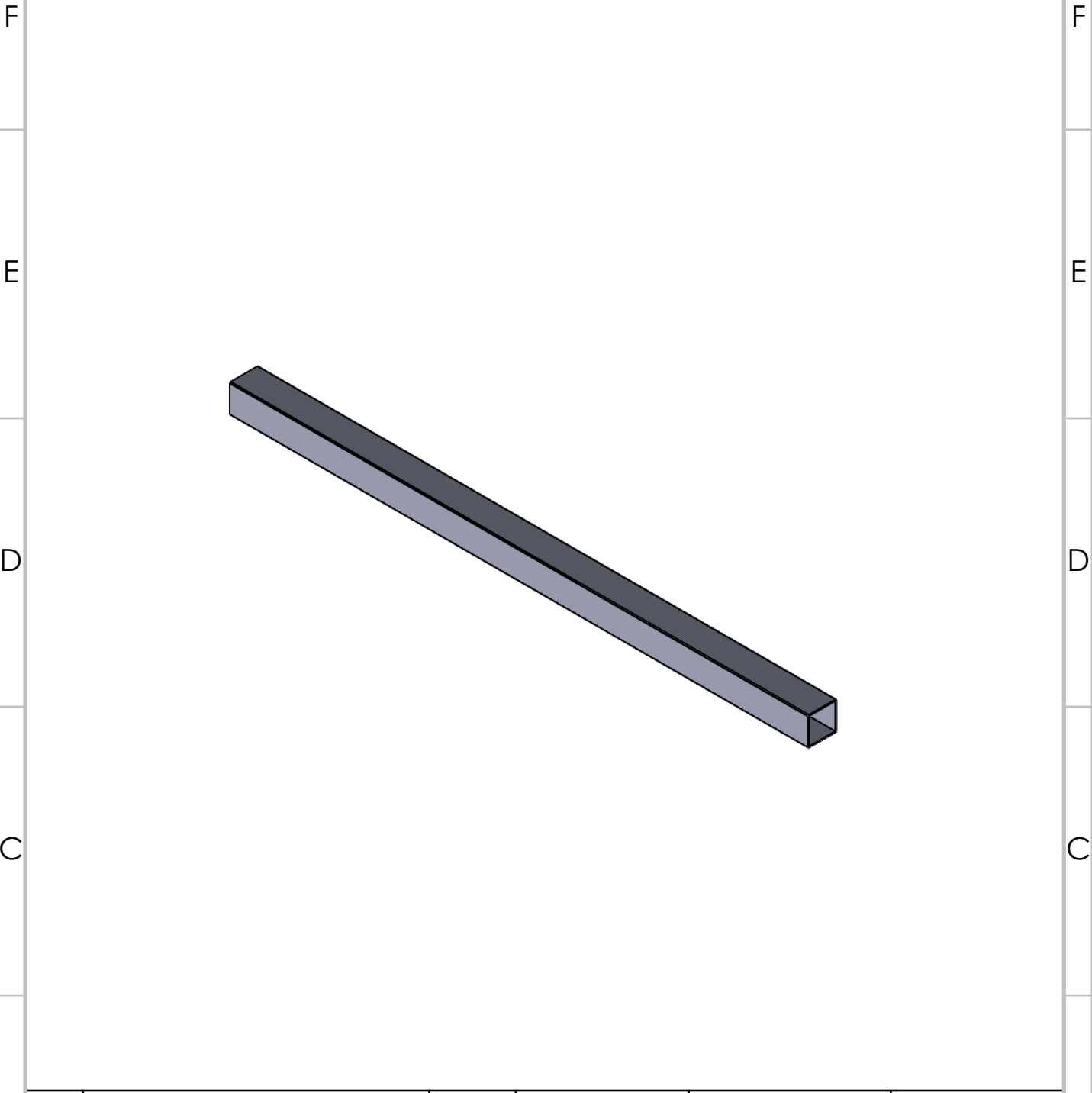

4 Kaki Meja		A2	Galvanis-	Lihat Detail	Dibuat		
Jml	Nama Bagian	No.Id	Bahan	Ukuran	Keterangan		
>	0 6 30 120 400 1000	Ukuran Lanjut:		No. Order:	Proyeksi:		
<	6 30 120 400 1000 2000						
Tol	±0.1 ±0.2 ±0.3 ±0.5 ±0.8 ±1.2						
Nama:				Skala 1:5	Digambar	1-8-22	Rendi
KAKI MEJA					Diperiksa		Radhi
					Disahkan		Bayu
No. Assy:				Format A4	Satuan mm		

No.	Perubahan	Tanggal	Nama	No.	Perubahan	Tanggal	Nama
△				△			

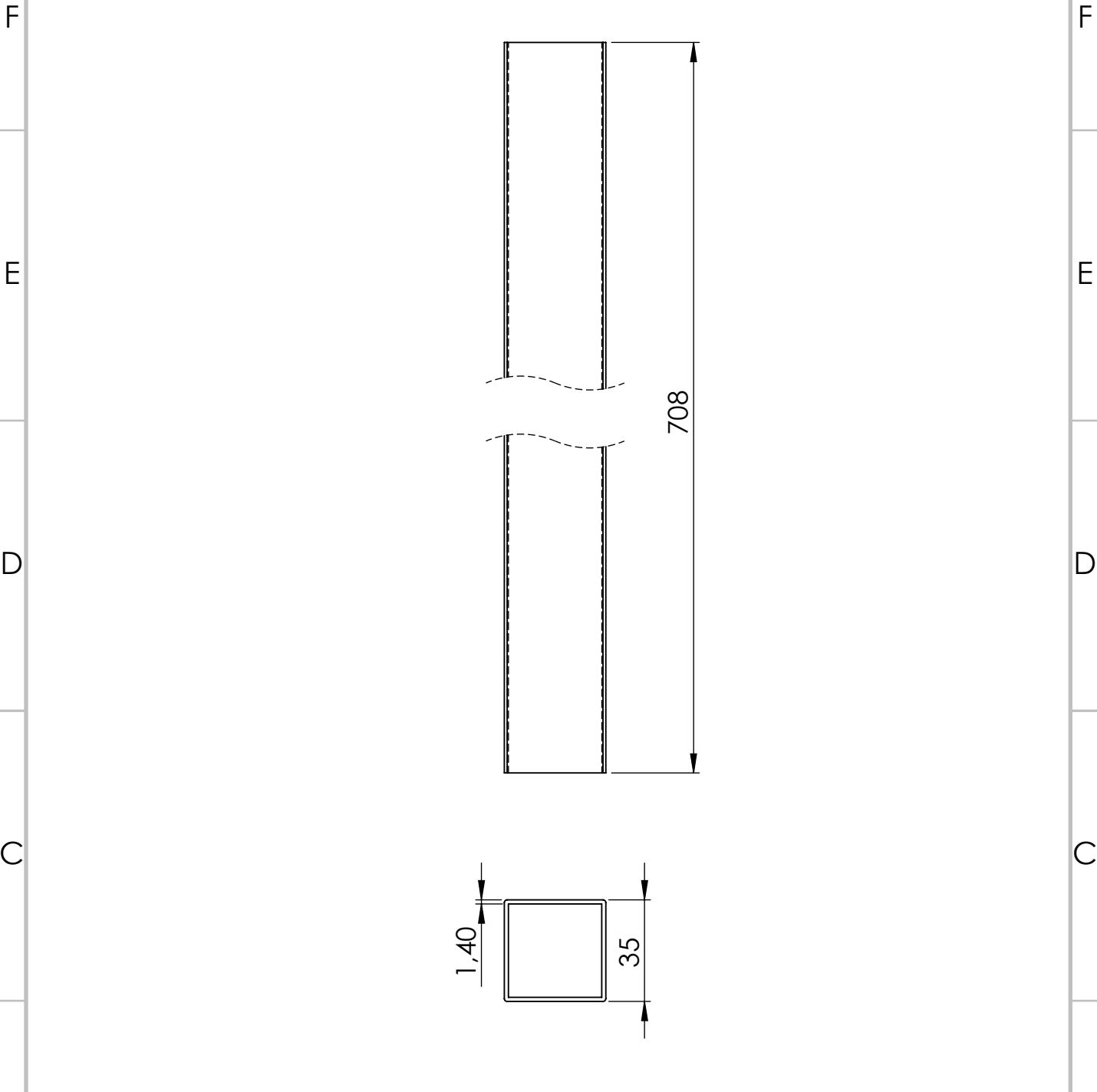



4 Kaki Meja							A2	Galvanis-	Lihat Detail	Dibuat		
Jml	Nama Bagian						No.Id	Bahan	Ukuran	Keterangan		
>	0	6	30	120	400	1000	Ukuran Lanjut:	No. Order:	Proyeksi:			
<	6	30	120	400	1000	2000						
Tol	±0.1	±0.2	±0.3	±0.5	±0.8	±1.2						
Nama:								Skala 1:2	Digambar	1-8-22	Rendi	
KAKI MEJA									Diperiksa		Radhi	
									Disahkan		Bayu	
No. Assy:												
Politeknik Negeri Cilacap, Jurusan Teknik Mesin Jl. Dr. Soetomo, No. 01, Sidakaya, Cilacap, 53212 Telp: 0282-533329, E-mail: tmpnc@politeknikcilacap.ac.id								Format A4	Satuan mm			

DILARANG MENGGANDAKAN, MENYALIN, MEMINDAHTANGKANKAN GAMBAR INI TANPA IZIN TERTULIS DARI POLITEKNIK NEGERI CILACAP

DILARANG MENGGANDAKAN, MENYALIN, MEMINDAHKAN GAMBAR INI TANPA IZIN TERTULIS DARI POLITEKNIK NEGERI CILACAP

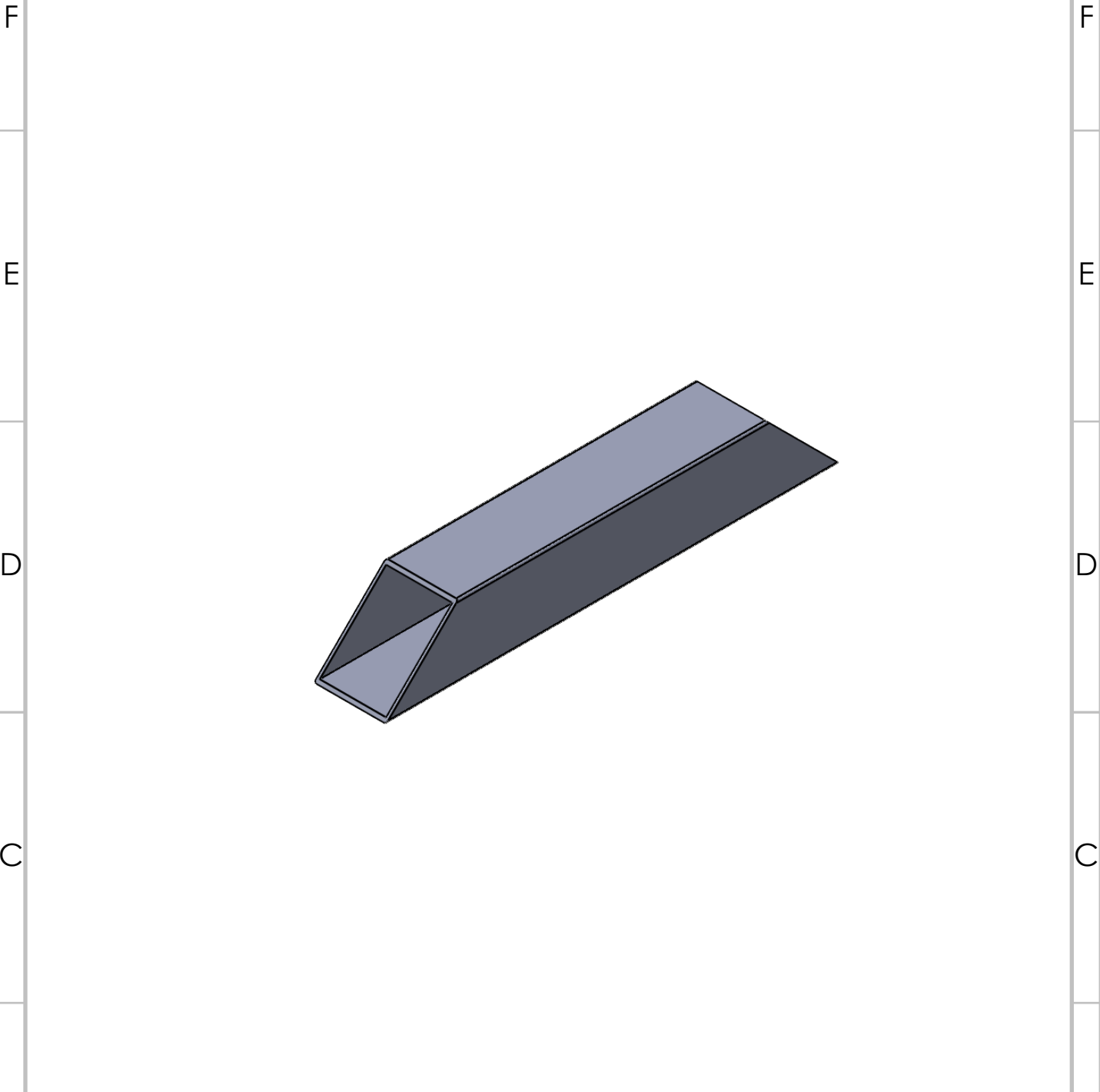
4		3			2		1
No.	Perubahan	Tanggal	Nama	No.	Perubahan	Tanggal	Nama
△				△			



8	Penguat Meja 45°					A3	Galvanis	Lihat Detail	Dibuat		
Jml	Nama Bagian					No.Id	Bahan	Ukuran	Keterangan		
>	0	6	30	120	400	1000	Ukuran Lanjut:	No. Order:	Proyeksi:		
<	6	30	120	400	1000	2000					
Tol	±0.1	±0.2	±0.3	±0.5	±0.8	±1.2					
Nama:								Skala 1:2	Digambar	1-8-22	Rendi
PENGUAT MEJA 45°									Diperiksa		Radhi
									Disahkan		Bayu
No. Assy:								Format A4	Satuan mm		
 Politeknik Negeri Cilacap, Jurusan Teknik Mesin Jl. Dr. Soetomo, No. 01, Sidakaya, Cilacap, 53212 Telp: 0282-533329, E-mail: tmpnc@politeknikcilacap.ac.id											

DILARANG MENGGANDAKAN, MENYALIN, MEMINDAHTANGKAN GAMBAR INI
TANPA IZIN TERTULIS DARI POLITEKNIK NEGERI CILACAP

4		3		2		1	
No.	Perubahan	Tanggal	Nama	No.	Perubahan	Tanggal	Nama
△				△			

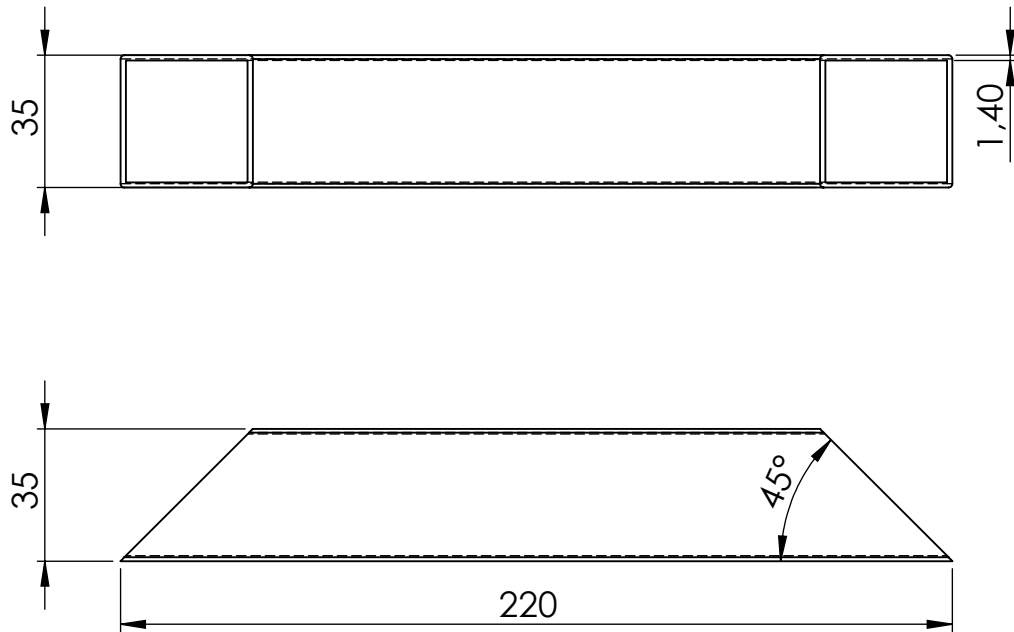

8	Penguat Meja 45°					A3	Galvanis	Lihat Detail	Dibuat		
Jml	Nama Bagian					No.Id	Bahan	Ukuran	Keterangan		
>	0	6	30	120	400	1000	Ukuran Lanjut:	No. Order:	Proyeksi:		
<	6	30	120	400	1000	2000					
Tol	±0.1	±0.2	±0.3	±0.5	±0.8	±1.2					
Nama:								Skala 1:2	Digambar	1-8-22	Rendi
PENGUAT MEJA 45°									Diperiksa		Radhi
									Disahkan		Bayu
No. Assy:								Format A4	Satuan mm		
Politeknik Negeri Cilacap, Jurusan Teknik Mesin Jl. Dr. Soetomo, No. 01, Sidakaya, Cilacap, 53212 Telp: 0282-533329, E-mail: tmpnc@politeknikcilacap.ac.id											

DILARANG MENGGANDAKAN, MENYALIN, MEMINDAHKAN GAMBAR INI
TANPA IZIN TERTULIS DARI POLITEKNIK NEGERI CILACAP

4		3			2		1
No.	Perubahan	Tanggal	Nama	No.	Perubahan	Tanggal	Nama
△				△			



2		Rusuk Meja 1					A4	Galvanis	Lihat Detail	Dibuat		
B		Jml Nama Bagian					No.Id	Bahan	Ukuran	Keterangan		
>	0	6	30	120	400	1000	Ukuran Lanjut:	No. Order:	Proyeksi:			
<	6	30	120	400	1000	2000						
Tol	±0.1	±0.2	±0.3	±0.5	±0.8	±1.2						
Nama:								Skala 1:5	Digambar	1-8-22	Rendi	
RUSUK MEJA 1									Diperiksa		Radhi	
									Disahkan		Bayu	
No. Assy:								Format A4	Satuan mm			
 Politeknik Negeri Cilacap, Jurusan Teknik Mesin Jl. Dr. Soetomo, No. 01, Sidakaya, Cilacap, 53212 Telp: 0282-533329, E-mail: tmpnc@politeknikcilacap.ac.id												

No.	Perubahan	Tanggal	Nama	No.	Perubahan	Tanggal	Nama
▲				▲			

F

F

E

E

D

D

C

C

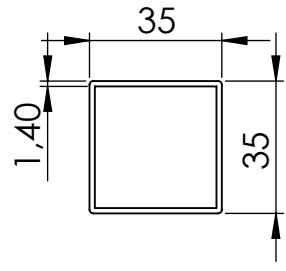
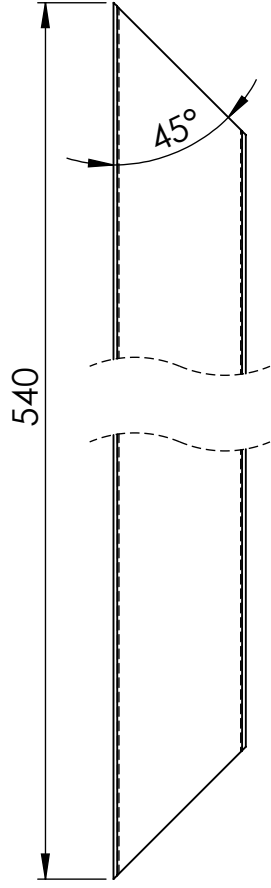

B

B

2	Rusuk Meja 2						A5	Galvanis	Lihat Detail	Dibuat
Jml	Nama Bagian						No.Id	Bahan	Ukuran	Keterangan
>	0	6	30	120	400	1000	Ukuran Lanjut:	No. Order:	Proyeksi:	
<	6	30	120	400	1000	2000				
Tol	±0.1	±0.2	±0.3	±0.5	±0.8	±1.2				

A

A

Nama: RUSUK MEJA 2 No. Assy:	Skala 1:2	Digambar	1-8-22	Rendi
		Diperiksa		Radhi
		Disahkan		Bayu

	Politeknik Negeri Cilacap, Jurusan Teknik Mesin Jl. Dr. Soetomo, No. 01, Sidakaya, Cilacap, 53212 Telp: 0282-533329, E-mail: tmpnc@politeknikcilacap.ac.id	Format A4	Satuan mm		
--	---	--------------	--------------	--	--

DILARANG MENGGANDAKAN, MENYALIN, MEMINDAHTANGKAN GAMBAR INI TANPA IZIN TERTULIS DARI POLITEKNIK NEGERI CILACAP

	4	3	2	1
No.	Perubahan	Tanggal	Nama	No.
△				△

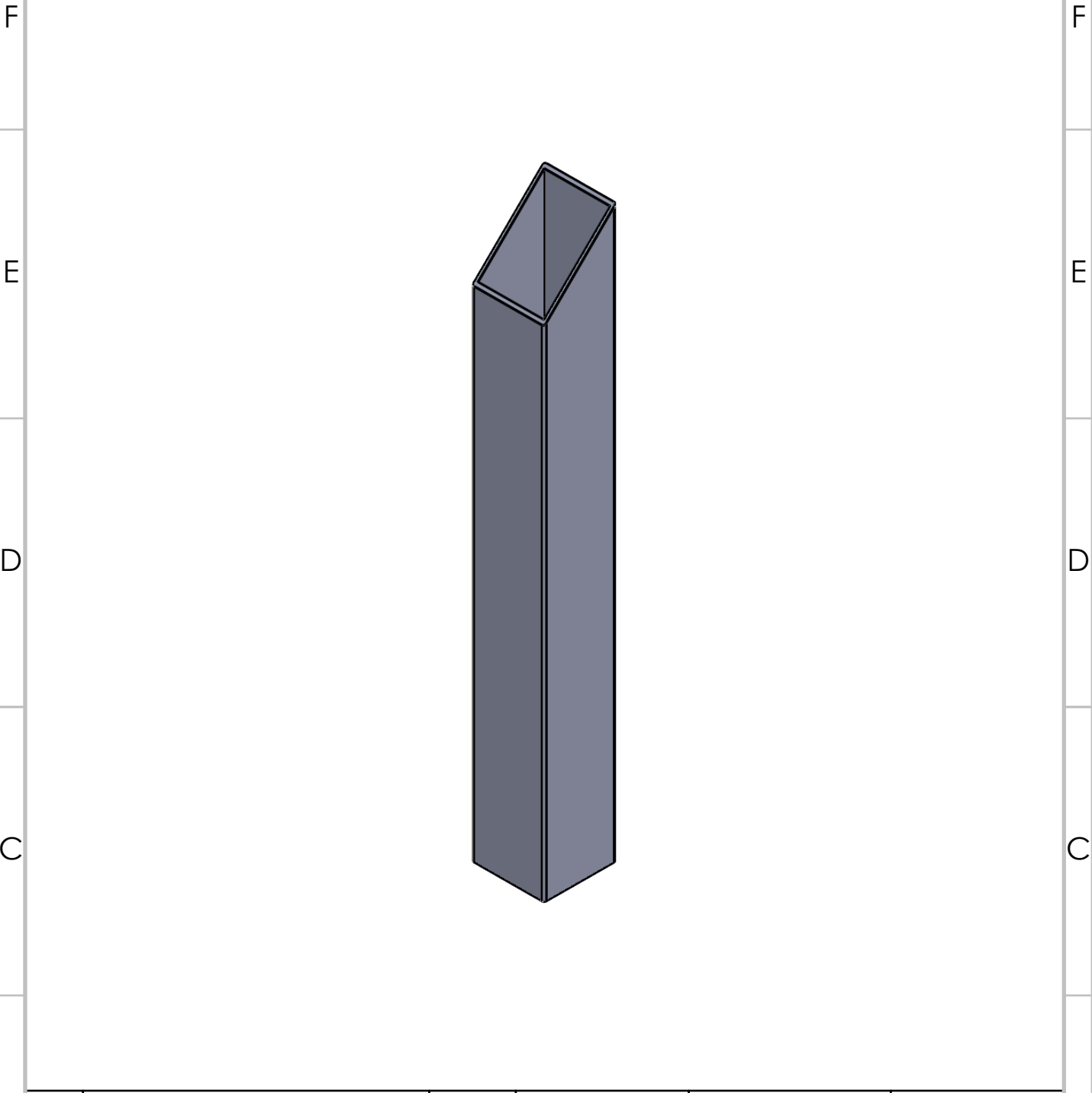

	2	Penyangga Transmisi					A6	Galvanis	Lihat Detail	Dibuat			
B	Jml	Nama Bagian					No.Id	Bahan	Ukuran	Keterangan			
	>	0	6	30	120	400	1000	Ukuran Lanjut: No. Order:		Proyeksi:			
	<	6	30	120	400	1000	2000						
	Tol	±0.1	±0.2	±0.3	±0.5	±0.8	±1.2						
	A	Nama: <div style="text-align: center; font-weight: bold; font-size: 1.2em;">PENYANGGA TRANSMISI</div> No. Assy:							Skala	Digambar	1-8-22	Rendi	
								1:2	Diperiksa			Radhi	
									Disahkan				Bayu
	A	Politeknik Negeri Cilacap, Jurusan Teknik Mesin Jl. Dr. Soetomo, No. 01, Sidakaya, Cilacap, 53212 Telp: 0282-533329, E-mail: tmpnc@politeknikcilacap.ac.id							Format	Satuan		mm	
								A4	mm				



DILARANG MENGGANDAKAN, MENYALIN, MEMINDAHKAN GAMBAR INI TANPA IZIN TERTULIS DARI POLITEKNIK NEGERI CILACAP

4		3		2			
No.	Perubahan	Tanggal	Nama	No.	Perubahan	Tanggal	Nama
△				△			

F
E
D
C
B
A

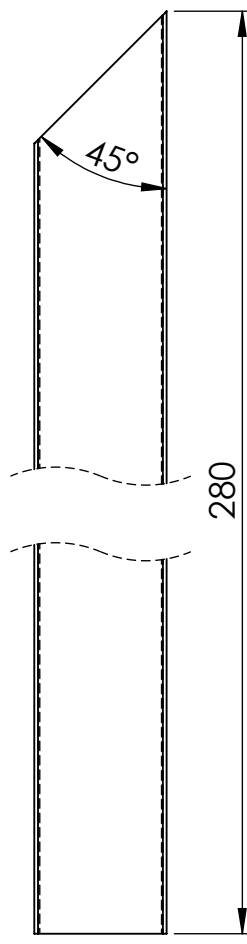
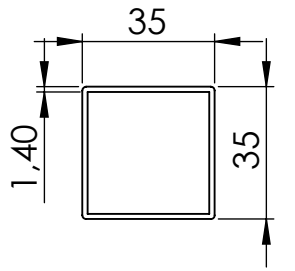
F
E
D
C
B
A

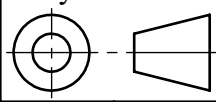

2	Penyangga Transmisi					A6	Galvanis	Lihat Detail	Dibuat		
Jml	Nama Bagian					No.Id	Bahan	Ukuran	Keterangan		
>	0	6	30	120	400	1000	Ukuran Lanjut: No. Order:		Proyeksi: 		
<	6	30	120	400	1000	2000					
Tol	±0.1	±0.2	±0.3	±0.5	±0.8	±1.2					
Nama:								Skala 1:2	Digambar	1-8-22	Rendi
PENYANGGA TRANSMISI									Diperiksa		Radhi
No. Assy:									Disahkan		Bayu
 Politeknik Negeri Cilacap, Jurusan Teknik Mesin Jl. Dr. Soetomo, No. 01, Sidakaya, Cilacap, 53212 Telp: 0282-533329, E-mail: tmpnc@politeknikcilacap.ac.id								Format A4	Satuan mm		

DILARANG MENGGANDAKAN, MENYALIN, MEMINDAHTANGKANKAN GAMBAR INI TANPA IZIN TERTULIS DARI POLITEKNIK NEGERI CILACAP

	4		3		2		1
No.	Perubahan	Tanggal	Nama	No.	Perubahan	Tanggal	Nama
△				△			

F
F
E
E
D
D
C
C

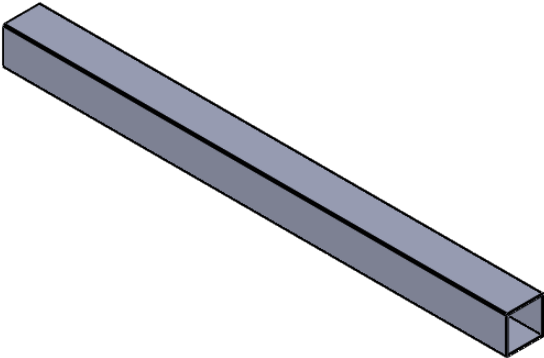

3	Palang Penguat Meja	A7	Galvanis	Lihat Detail	Dibuat		
B	Jml Nama Bagian	No.Id	Bahan	Ukuran	Keterangan		
>	0	6	30	120	400	1000	Ukuran Lanjut: No. Order: Proyeksi:
<	6	30	120	400	1000	2000	
Tol	±0.1	±0.2	±0.3	±0.5	±0.8	±1.2	

Nama: <div style="text-align: center; font-size: 1.2em; font-weight: bold;">PALANG PENGUAT MEJA</div> No. Assy:	Skala 1:5	Digambar Diperiksa Disahkan	1-8-22 	Rendi Radhi Bayu
--	--------------------------------	-----------------------------------	--------------------	------------------------

	Politeknik Negeri Cilacap, Jurusan Teknik Mesin Jl. Dr. Soetomo, No. 01, Sidakaya, Cilacap, 53212 Telp: 0282-533329, E-mail: tmpnc@politeknikcilacap.ac.id	Format A4	Satuan mm		
---	---	----------------------------	----------------------------	--	--

4

3

2

1
PENGGANTI DARI:
DIGANTI DENGAN:

	4	3		2		
No.	Perubahan	Tanggal	Nama	No.	Perubahan	Tanggal
▲				▲		

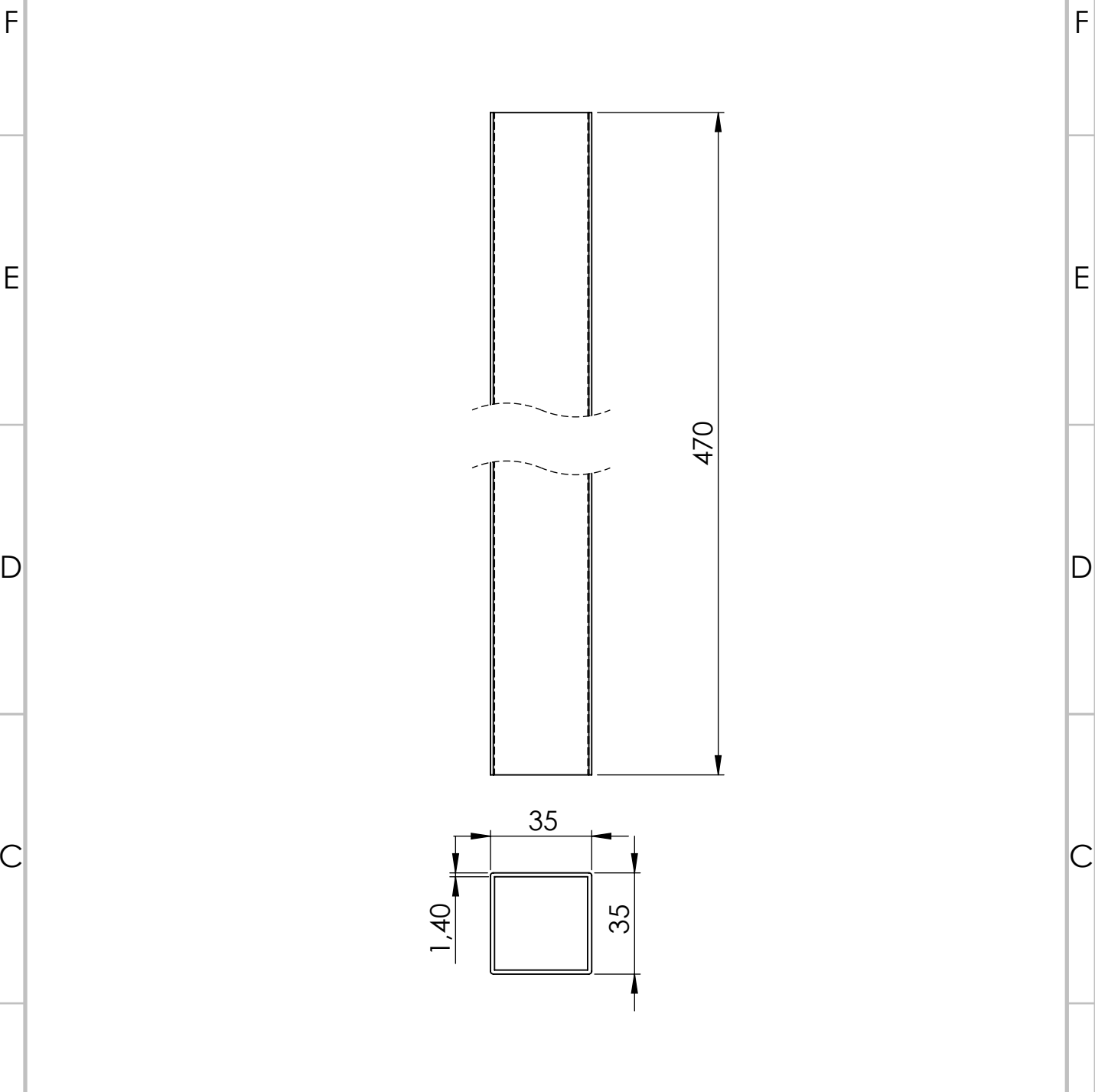

	3	Palang Penguat Meja	A7	Galvanis	Lihat Detail	Dibuat	
B	Jml	Nama Bagian	No.Id	Bahan	Ukuran	Keterangan	
	>	0	6	30	120	400	
	<	6	30	120	400	1000	
	Tol	±0.1	±0.2	±0.3	±0.5	±0.8	
		±1.2	Ukuran Lanjut:			No. Order:	Proyeksi:
	Nama:					Skala	1-8-22
	PALANG PENGUAT MEJA					1:2	Rendi
	No. Assy:					Digambar	Radhi
	Politeknik Negeri Cilacap, Jurusan Teknik Mesin					Diperiksa	Bayu
	Jl. Dr. Soetomo, No. 01, Sidakaya, Cilacap, 53212					Disahkan	
	Telp: 0282-533329, E-mail: tmpnc@politeknikcilacap.ac.id					Format	Satuan
	A4					mm	

4		3				2		1
No.	Perubahan	Tanggal	Nama	No.	Perubahan	Tanggal	Nama	
△				△				

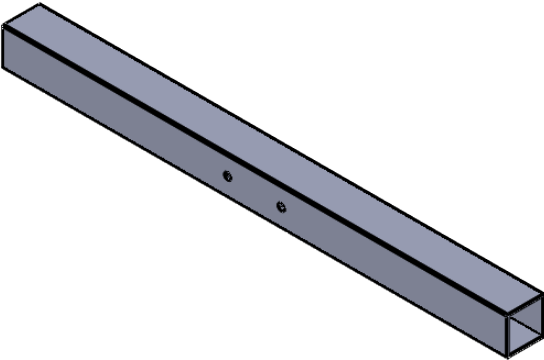

1 Dudukan Bantalan 1							A8	Galvanis	Lihat Detail	Dibuat		
Jml	Nama Bagian						No.Id	Bahan	Ukuran	Keterangan		
>	0	6	30	120	400	1000	Ukuran Lanjut:	No. Order:	Proyeksi:			
<	6	30	120	400	1000	2000						
Tol	±0.1	±0.2	±0.3	±0.5	±0.8	±1.2						

Nama:	1:5	Digambar	1-8-22	Rendi
<h2>DUDUKAN BANTALAN 1</h2>		Diperiksa		Radhi
		Disahkan		Bayu

No. Assy:	Format A4	Satuan mm		
-----------	---------------------	---------------------	--	--



Politeknik Negeri Cilacap, Jurusan Teknik Mesin
 Jl. Dr. Soetomo, No. 01, Sidakaya, Cilacap, 53212
 Telp: 0282-533329, E-mail: tmpnc@politeknikcilacap.ac.id

4		3				2		1
---	--	---	--	--	--	---	--	---

PENGGANTI DARI: DIGANTI DENGAN

4	3	2	1
No.	Perubahan	Tanggal	Nama
No.	Perubahan	Tanggal	Nama

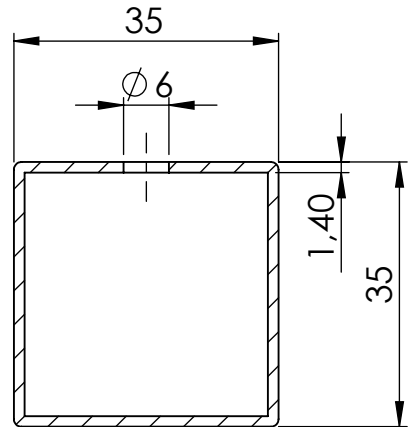
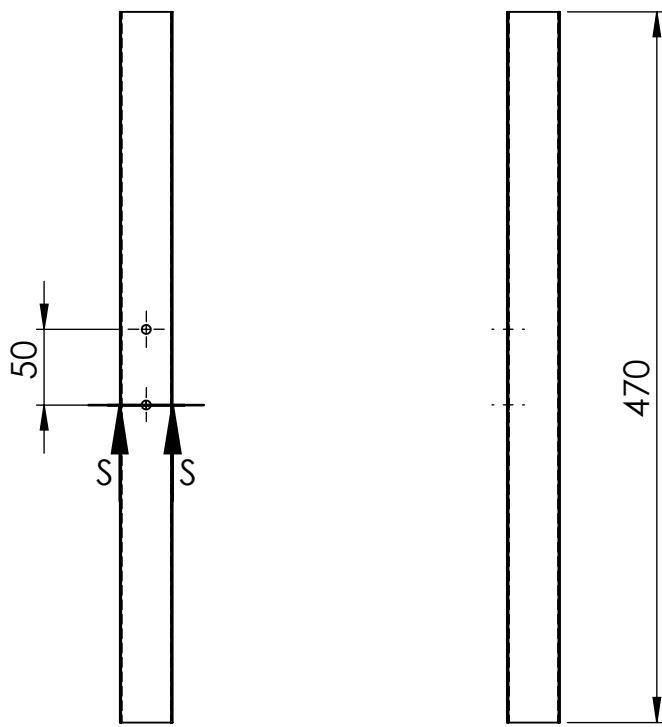

SECTION S-S
SCALE 1 : 1

1	Dudukan Bantalan 1						A8	Galvanis	Lihat Detail	Dibuat
>	0	6	30	120	400	1000	Ukuran Lanjut:	No. Order:	Proyeksi:	
<	6	30	120	400	1000	2000				
Tol	±0.1	±0.2	±0.3	±0.5	±0.8	±1.2				

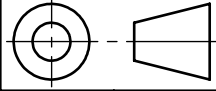

Nama:	1:5	Digambar	1-8-22	Rendi
DUDUKAN BANTALAN 1		Diperiksa		Radhi
No. Assy:		Disahkan		Bayu

Politeknik Negeri Cilacap, Jurusan Teknik Mesin Jl. Dr. Soetomo, No. 01, Sidakaya, Cilacap, 53212 Telp: 0282-533329, E-mail: tmpnc@politeknikcilacap.ac.id	Format A4	Satuan mm		
---	---------------------	---------------------	--	--

	4	3	2	1
No.	Perubahan	Tanggal	Nama	No.
△				△

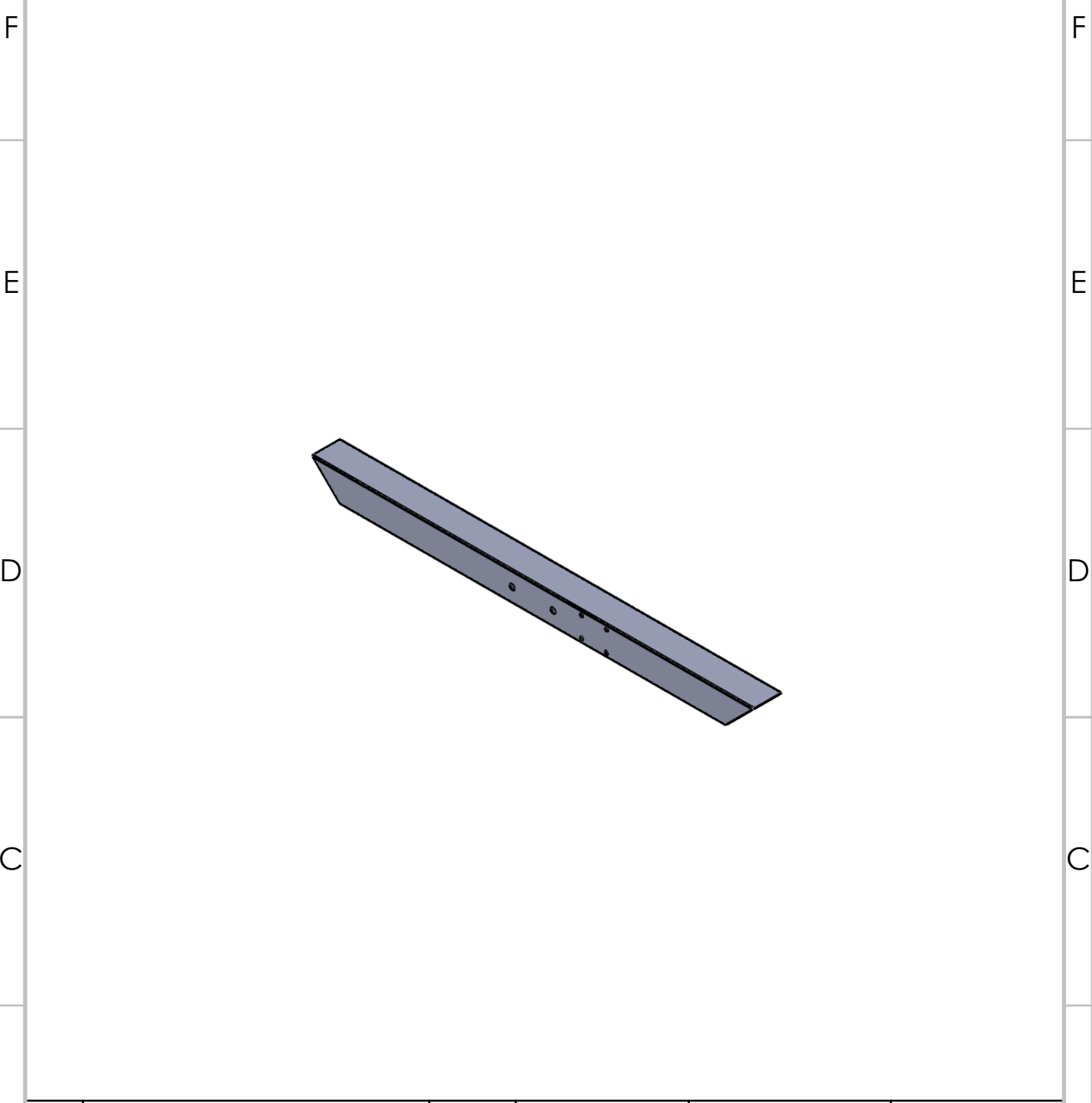

1	Dudukan Bantalan 2						A9	Galvanis	Lihat Detail	Dibuat		
B	Jml Nama Bagian						No.Id	Bahan	Ukuran	Keterangan		
>	0	6	30	120	400	1000	Ukuran Lanjut:		No. Order:		Proyeksi:	
<	6	30	120	400	1000	2000						
Tol	±0.1	±0.2	±0.3	±0.5	±0.8	±1.2						

Nama:	1:5	Digambar	1-8-22	Rendi
DUDUKAN BANTALAN 2		Diperiksa		Radhi
		Disahkan		Bayu
No. Assy:				

Politeknik Negeri Cilacap, Jurusan Teknik Mesin Jl. Dr. Soetomo, No. 01, Sidakaya, Cilacap, 53212 Telp: 0282-533329, E-mail: tmpnc@politeknikcilacap.ac.id	Format	Satuan		
	A4	mm		

4		3		2		1	
No.	Perubahan	Tanggal	Nama	No.	Perubahan	Tanggal	Nama
△				△			

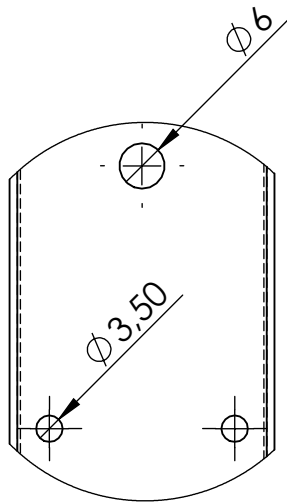

DETAIL Q
SCALE 1 : 1

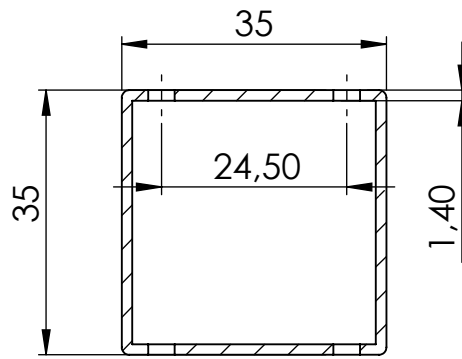
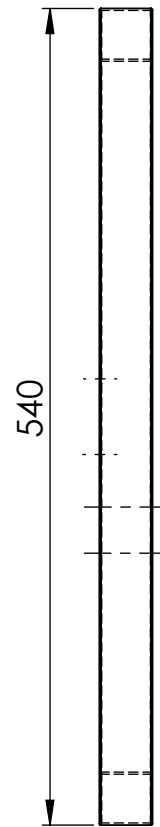
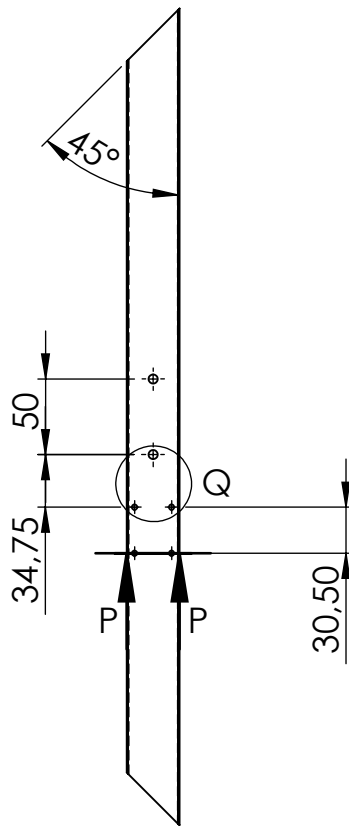

SECTION P-P
SCALE 1 : 1

1	Dudukan Bantalan 2						A9	Galvanis	Lihat Detail	Dibuat
Jml	Nama Bagian						No.Id	Bahan	Ukuran	Keterangan
>	0	6	30	120	400	1000	Ukuran Lanjut:	No. Order:	Proyeksi: 	
<	6	30	120	400	1000	2000				
Tol	±0.1	±0.2	±0.3	±0.5	±0.8	±1.2				

Nama:

DUDUKAN BANTALAN 2

No. Assy:

Skala

1:5

Format
A4

Digambar

Diperiksa

Disahkan

Satuan
mm

1-8-22

Rendi

Radhi

Bayu



Politeknik Negeri Cilacap, Jurusan Teknik Mesin

Jl. Dr. Soetomo, No. 01, Sidakaya, Cilacap, 53212

Telp: 0282-533329, E-mail: tmpnc@politeknikcilacap.ac.id

DILARANG MENGGANDAKAN, MENYALIN, MEMINDAHTANGKAN GAMBAR INI
TANPA IZIN TERTULIS DARI POLITEKNIK NEGERI CILACAP

	4	3	2	1
No.	Perubahan	Tanggal	Nama	No.
No.	Perubahan	Tanggal	Nama	No.

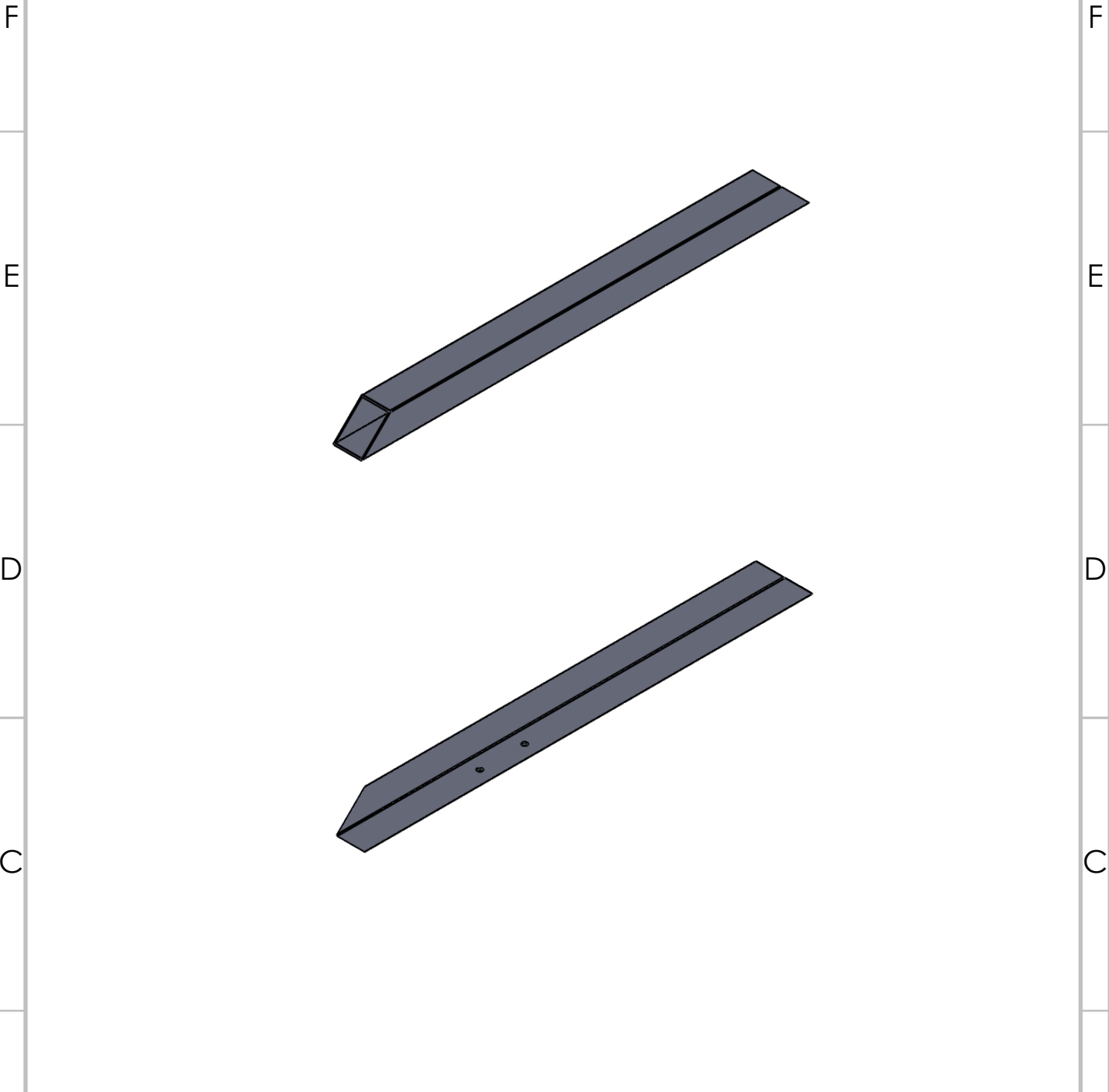

2	Dudukan Clamp Pipa 1 Inchi						A10	Galvanis	Lihat Detail	Dibuat		
B	Jml Nama Bagian						No.Id	Bahan	Ukuran	Keterangan		
	>	0	6	30	120	400	1000	Ukuran Lanjut:	No. Order:	Proyeksi:		
	<	6	30	120	400	1000	2000					
	Tol	±0.1	±0.2	±0.3	±0.5	±0.8	±1.2					

Nama:	1:5	Digambar	1-8-22	Rendi
DUDUKAN CLAMP PIPA 1		Diperiksa		Radhi
		Disahkan		Bayu
No. Assy:				

Politeknik Negeri Cilacap, Jurusan Teknik Mesin Jl. Dr. Soetomo, No. 01, Sidakaya, Cilacap, 53212 Telp: 0282-533329, E-mail: tmpnc@politeknikcilacap.ac.id	Format A4	Satuan mm		
---	---------------------	---------------------	--	--

4		3		2		1	
No.	Perubahan	Tanggal	Nama	No.	Perubahan	Tanggal	Nama
△				△			

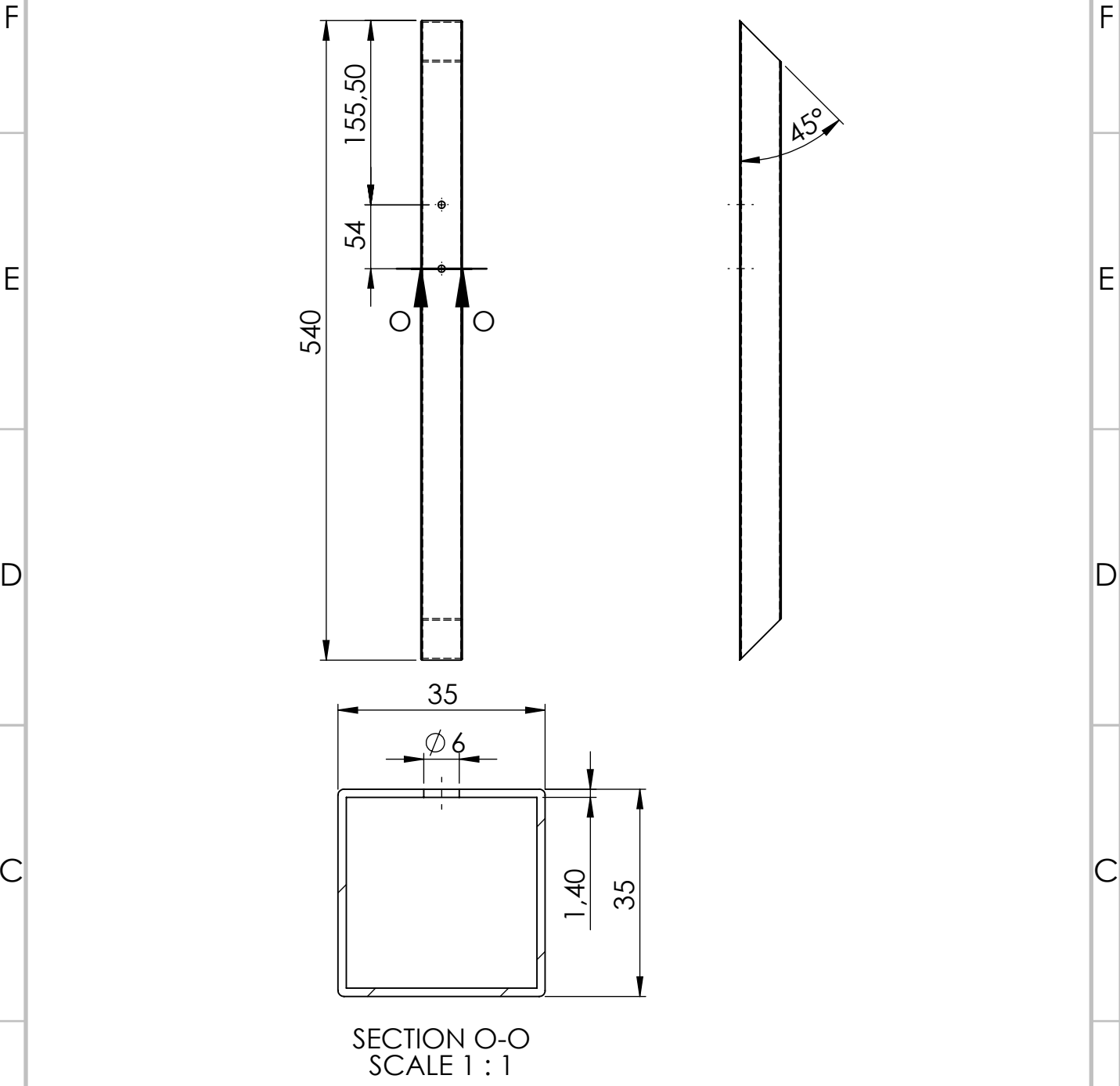

2	Dudukan Clamp Pipa 1 Inchi						A10	Galvanis	Lihat Detail	Dibuat		
B	Jml	Nama Bagian					No.Id	Bahan	Ukuran	Keterangan		
	>	0	6	30	120	400	1000	Ukuran Lanjut:	No. Order:	Proyeksi:		
	<	6	30	120	400	1000	2000					
	Tol	±0.1	±0.2	±0.3	±0.5	±0.8	±1.2					
A	Nama:								Skala 1:5	Digambar	1-8-22	Rendi
	DUDUKAN CLAMP PIPA 1									Diperiksa		Radhi
										No. Assy:		
	Politeknik Negeri Cilacap, Jurusan Teknik Mesin Jl. Dr. Soetomo, No. 01, Sidakaya, Cilacap, 53212 Telp: 0282-533329, E-mail: tmpnc@politeknikcilacap.ac.id								Format A4			

DILARANG MENGGANDAKAN, MENYALIN, MEMINDAHKAN GAMBAR INI TANPA IZIN TERTULIS DARI POLITEKNIK NEGERI CILACAP

DILARANG MENGGANDAKAN, MENYALIN, MEMINDAHKAN GAMBAR INI
TANPA IZIN TERTULIS DARI POLITEKNIK NEGERI CILACAP

4		3			2		1
No.	Perubahan	Tanggal	Nama	No.	Perubahan	Tanggal	Nama
△				△			

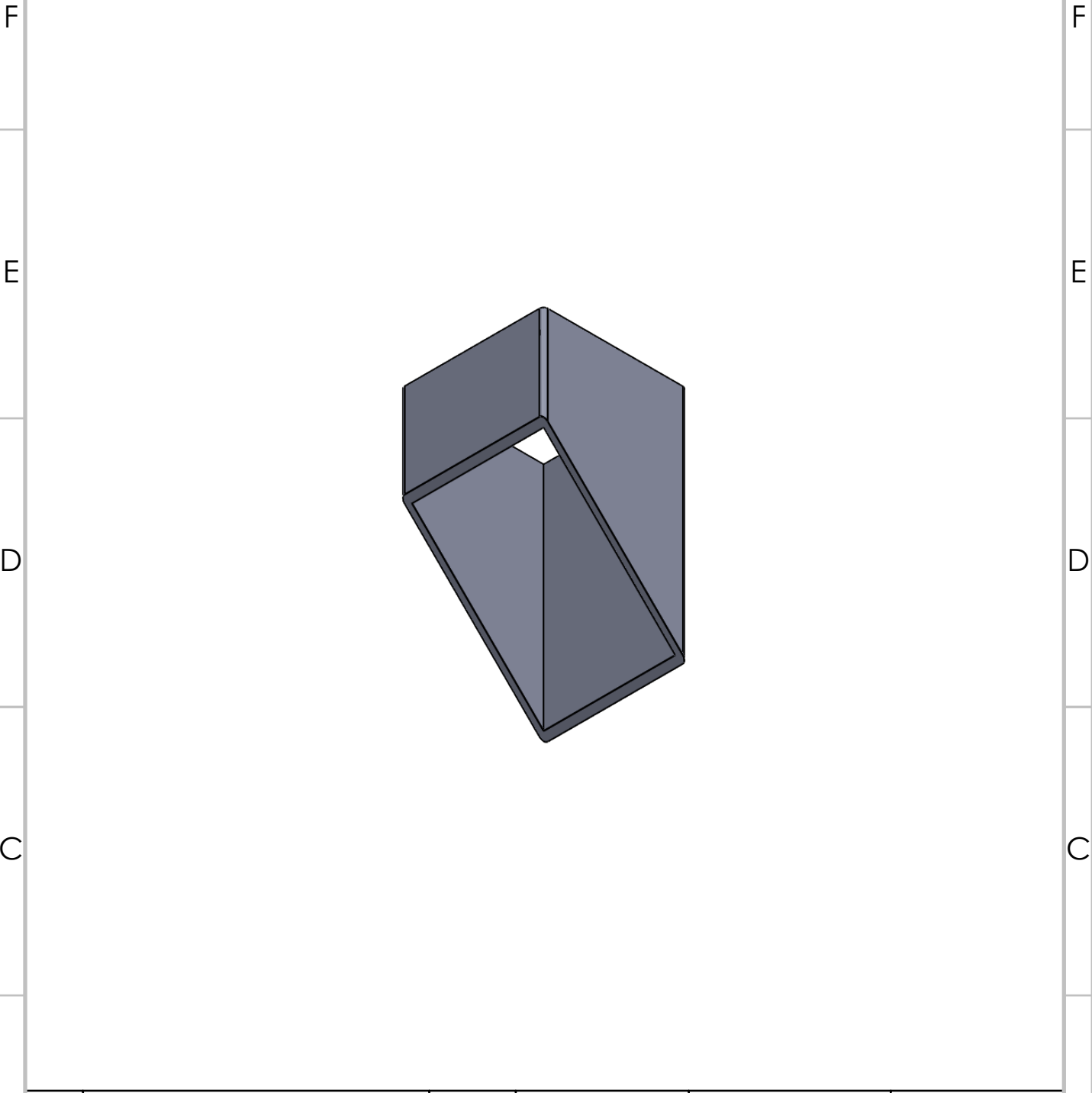

4	Dudukan Clamp Pipa 2					A11	Galvanis	Lihat Detail	Dibuat		
B	Jml	Nama Bagian					No.Id	Bahan	Ukuran	Keterangan	
	>	0	6	30	120	400	1000	Ukuran Lanjut:	No. Order:	Proyeksi:	
	<	6	30	120	400	1000	2000				
	Tol	±0.1	±0.2	±0.3	±0.5	±0.8	±1.2				
Nama:								Skala 1:1	Digambar	1-8-22	Rendi
DUDUKAN CLAMP PIPA 2									Diperiksa		Radhi
No. Assy:									Disahkan		Bayu
Politeknik Negeri Cilacap, Jurusan Teknik Mesin								Format A4	Satuan mm		
Jl. Dr. Soetomo, No. 01, Sidakaya, Cilacap, 53212 Telp: 0282-533329, E-mail: tmpnc@politeknikcilacap.ac.id											

DILARANG MENGGANDAKAN, MENYALIN, MEMINDAHKAN GAMBAR INI TANPA IZIN TERTULIS DARI POLITEKNIK NEGERI CILACAP

	4	3	2	
No.	Perubahan	Tanggal	Nama	No.
No.	Perubahan	Tanggal	Nama	

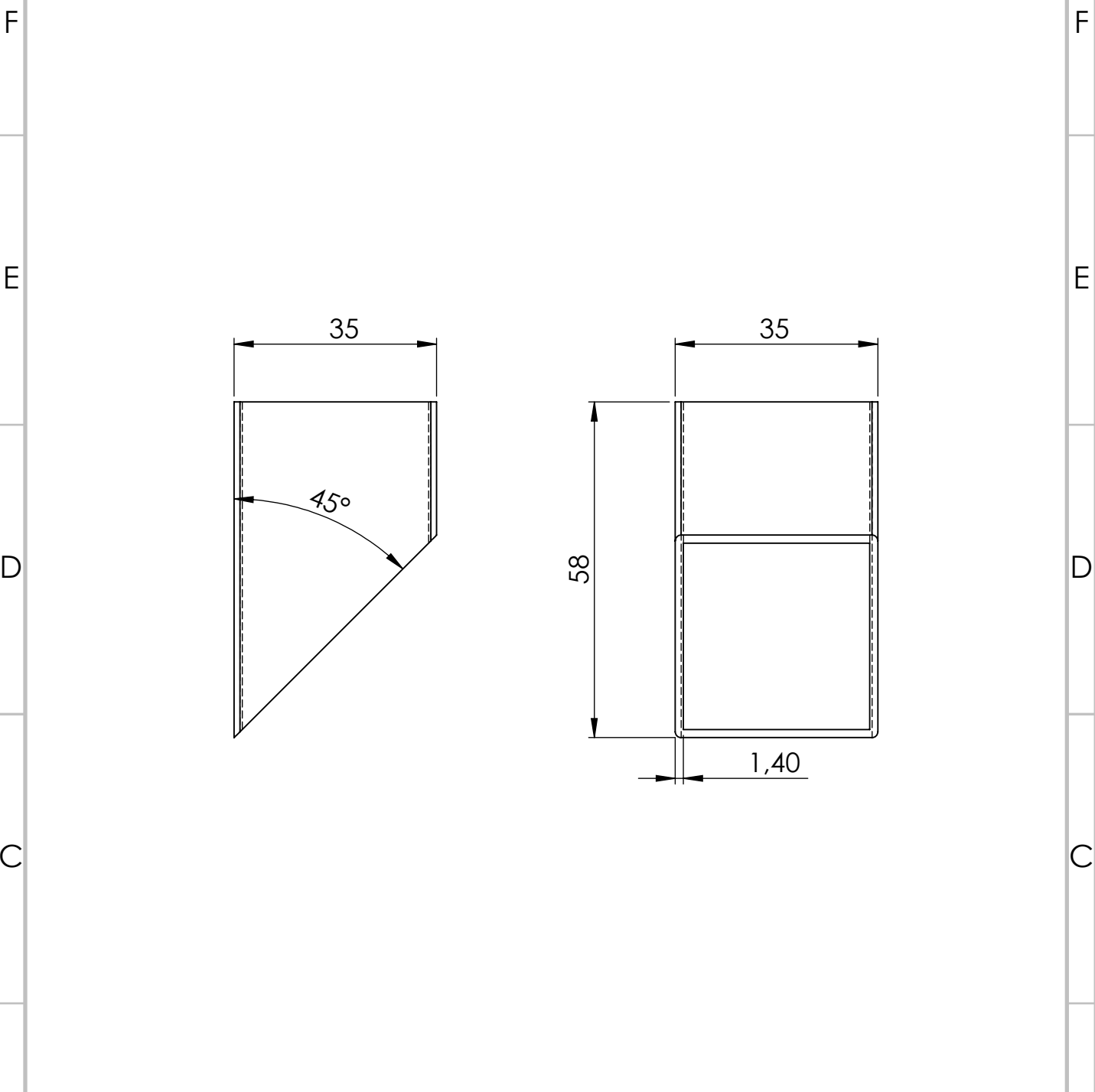

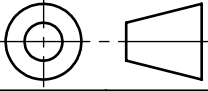
4	Dudukan Clamp Pipa 2	A11	Galvanis	Lihat Detail	Dibuat
Jml	Nama Bagian	No.Id	Bahan	Ukuran	Keterangan
>	0 6 30 120 400 1000	Ukuran Lanjut:		No. Order:	Proyeksi: 
<	6 30 120 400 1000 2000				
Tol	±0.1 ±0.2 ±0.3 ±0.5 ±0.8 ±1.2				

Nama:	1:1	Digambar	1-8-22	Rendi
DUDUKAN CLAMP PIPA 2		Diperiksa		Radhi
		Disahkan		Bayu
No. Assy:				

 Politeknik Negeri Cilacap, Jurusan Teknik Mesin Jl. Dr. Soetomo, No. 01, Sidakaya, Cilacap, 53212 Telp: 0282-533329, E-mail: tmpnc@politeknikcilacap.ac.id	Format A4	Satuan mm		
---	---------------------	---------------------	--	--

LAMPIRAN 9

Runner

DILARANG MENGGANDAKAN, MENYALIN, MEMINDAHTANGANKAN GAMBAR INI
TANPA IZIN TERTULIS DARI POLITEKNIK NEGERI CILACAP

4		3			2		1
No.	Perubahan	Tanggal	Nama	No.	Perubahan	Tanggal	Nama
△				△			

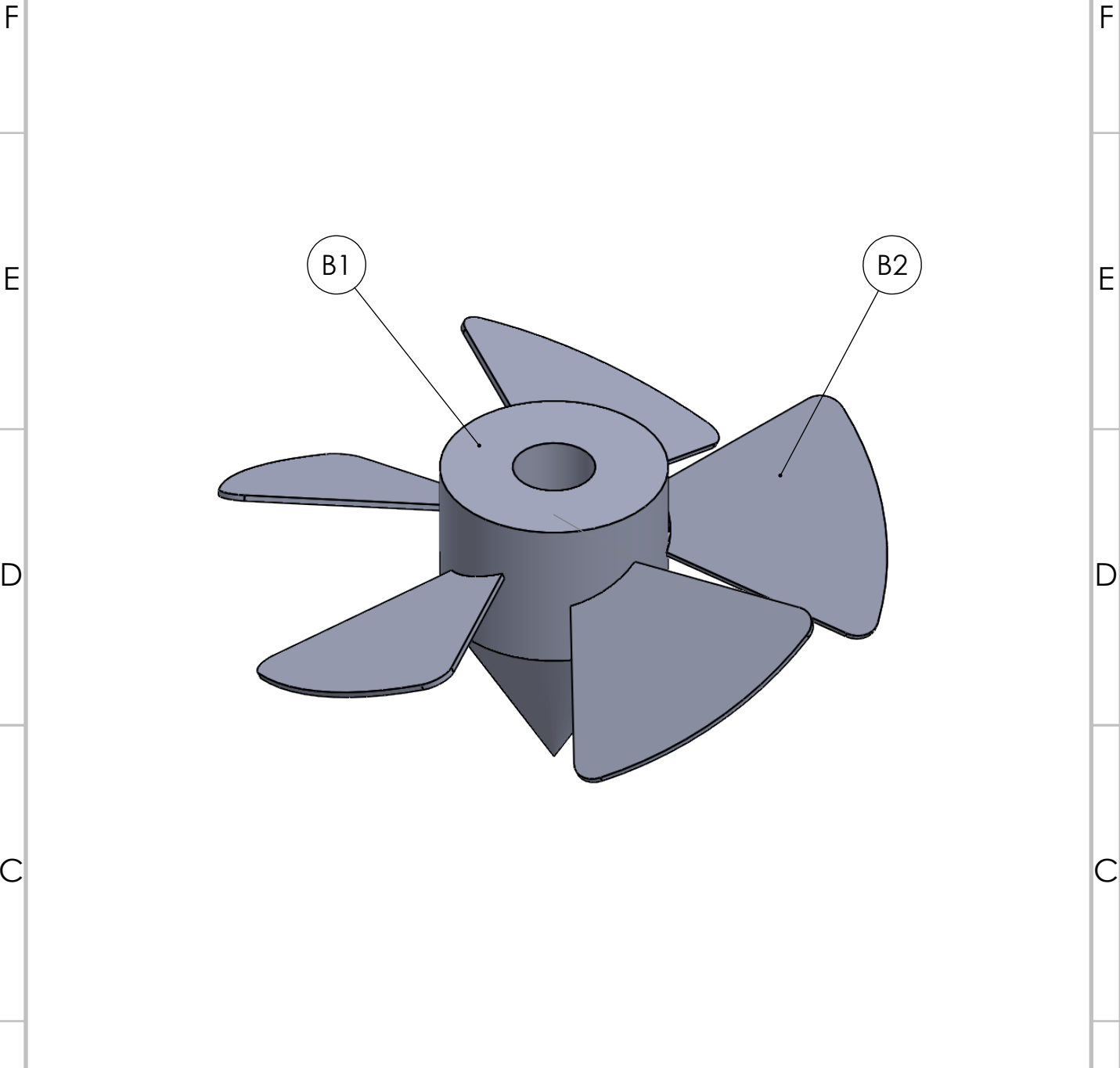

2	Blade					B2	Stainless 430	Lihat Detail	Dibuat	
1	Hub					B1	S45C	Lihat Detail	Dibuat	
B	Jml	Nama Bagian					No.Id	Bahan	Ukuran	Keterangan
	>	0	6	30	120	400	1000	Ukuran Lanjut:	No. Order:	Proyeksi:
	<	6	30	120	400	1000	2000			
	Tol	0.1	0.2	0.3	0.5	0.8	1.2			

Nama:				Skala 2:1	Digambar	1-8-22	Rendi
SUB ASSEMBLY RUNNER					Diperiksa		Radhi
					Disahkan		Bayu
No. Assy:							

 Politeknik Negeri Cilacap, Jurusan Teknik Mesin Jl. Dr. Soetomo, No. 01, Sidakaya, Cilacap, 53212 Telp: 0282-533329, E-mail: tmpnc@politeknikcilacap.ac.id				Format A4	Satuan mm		
---	--	--	--	--------------	--------------	--	--

DILARANG MENGGANDAKAN, MENYALIN, MEMINDAHTANGKAN GAMBAR INI TANPA IZIN TERTULIS DARI POLITEKNIK NEGERI CILACAP

4		3		2		1	
No.	Perubahan	Tanggal	Nama	No.	Perubahan	Tanggal	Nama
△				△			

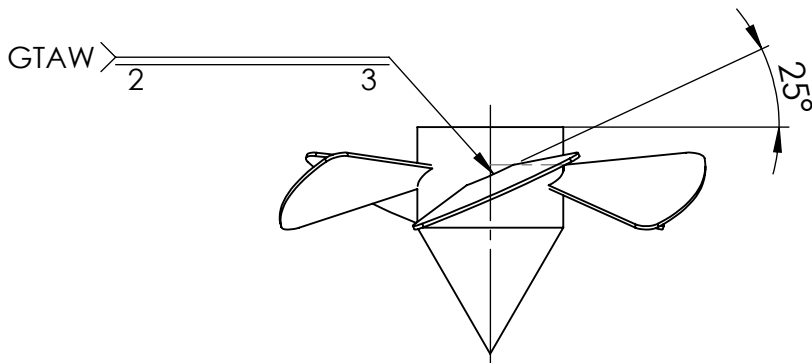
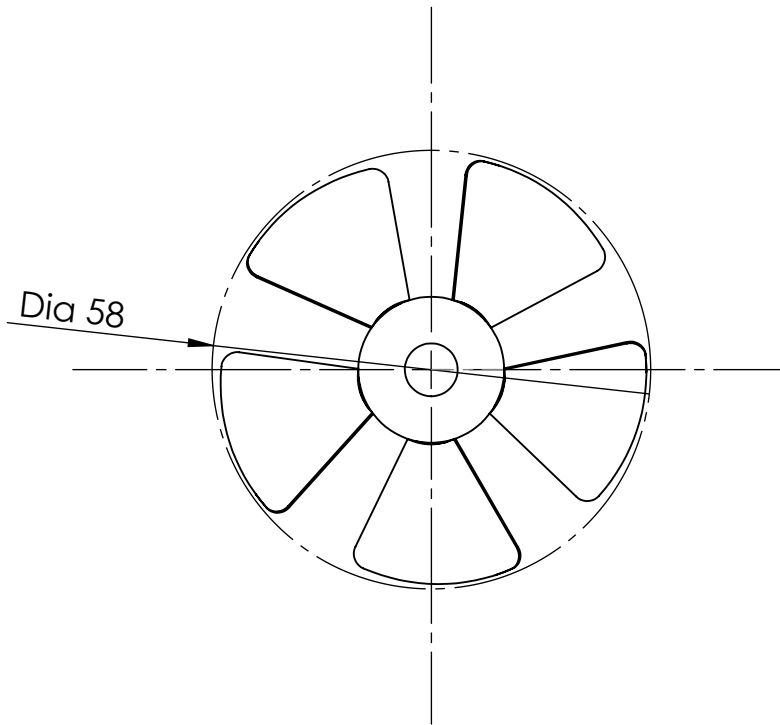

2	Blade					B2	Stainless 430	Lihat Detail	Dibuat	
1	Hub					B1	S45C	Lihat Detail	Dibuat	
B	Jml	Nama Bagian					No.Id	Bahan	Ukuran	Keterangan
	>	0	6	30	120	400	1000	Ukuran Lanjut:	No. Order:	Proyeksi:
	<	6	30	120	400	1000	2000			
	Tol	0.1	0.2	0.3	0.5	0.8	1.2			

Nama:				Skala 1:1	Digambar	1-8-22	Rendi
SUB ASSEMBLY RUNNER					Diperiksa		Radhi
					Disahkan		Bayu
No. Assy:							

Politeknik Negeri Cilacap, Jurusan Teknik Mesin Jl. Dr. Soetomo, No. 01, Sidakaya, Cilacap, 53212 Telp: 0282-533329, E-mail: tmpnc@politeknikcilacap.ac.id				Format A4	Satuan mm		
---	--	--	--	--------------	--------------	--	--

4

3

2

1

No.	Perubahan	Tanggal	Nama	No.	Perubahan	Tanggal	Nama
△				△			

F

F

E

E

D

D

C

C

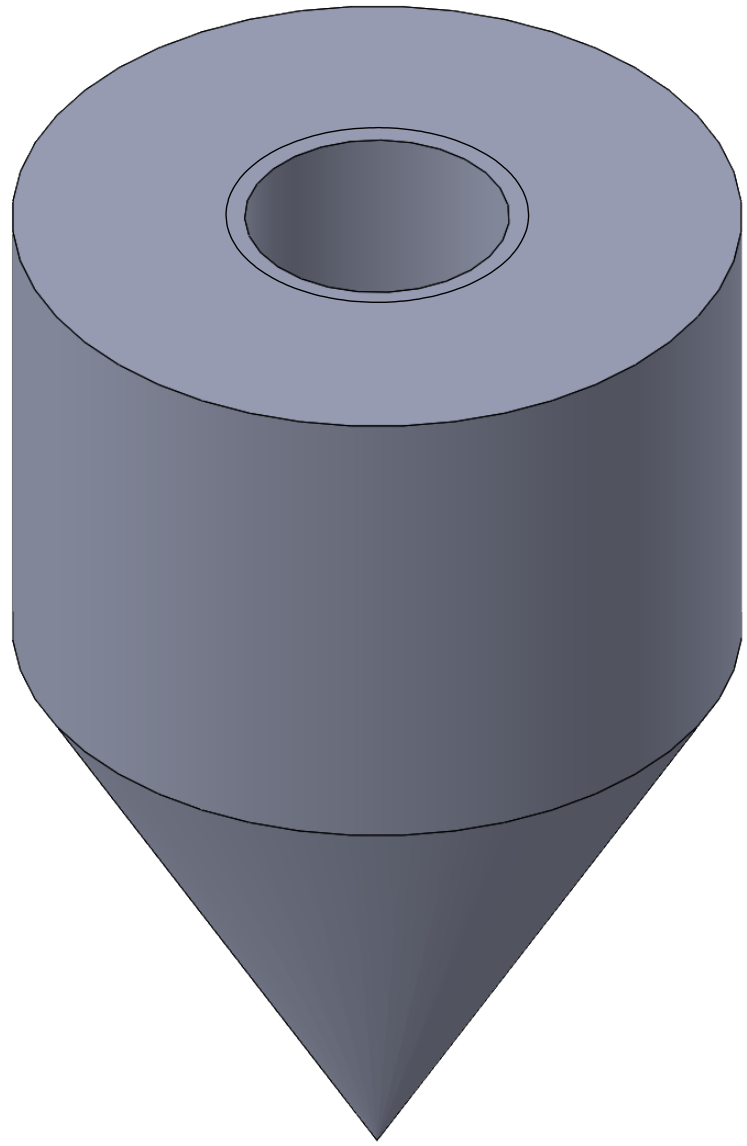

B

B

1	Hub						B1	S45C	Lihat Detail	Dibuat		
Jml	Nama Bagian						No.Id	Bahan	Ukuran	Keterangan		
>	0	6	30	120	400	1000	Ukuran Lanjut:	No. Order:	Proyeksi:			
<	6	30	120	400	1000	2000						
Tol	0.1	0.2	0.3	0.5	0.8	1.2						

A

A

Nama:								Skala 5:1	Digambar	1-8-22	Rendi
HUB									Diperiksa		Radhi
									Disahkan		Bayu
No. Assy:											

 Politeknik Negeri Cilacap, Jurusan Teknik Mesin Jl. Dr. Soetomo, No. 01, Sidakaya, Cilacap, 53212 Telp: 0282-533329, E-mail: tmpnc@politeknikcilacap.ac.id								Format A4	Satuan mm		
---	--	--	--	--	--	--	--	--------------	--------------	--	--

4

3

2

1

PENGGANTI DARI:

DIGANTI DENGAN

DILARANG MENGGANDAKAN, MENYALIN, MEMINDAHTANGKAN GAMBAR INI
 TANPA IZIN TERTULIS DARI POLITEKNIK NEGERI CILACAP

4		3		2		1	
No.	Perubahan	Tanggal	Nama	No.	Perubahan	Tanggal	Nama
△				△			

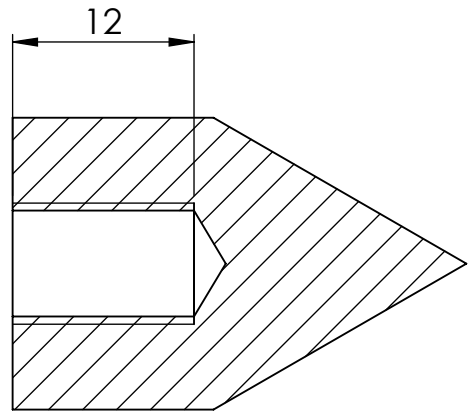
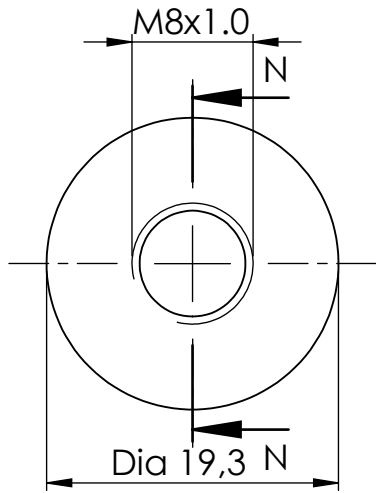

SECTION N-N

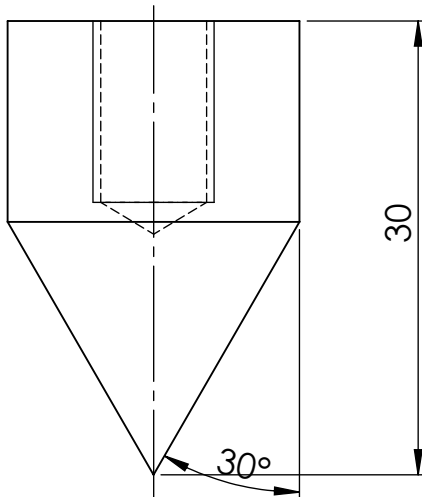

1	Hub						B1	S45C	Lihat Detail	Dibuat
B	Nama Bagian						No.Id	Bahan	Ukuran	Keterangan
>	0	6	30	120	400	1000	Ukuran Lanjut:	No. Order:	Proyeksi: 	
<	6	30	120	400	1000	2000				
Tol	0.1	0.2	0.3	0.5	0.8	1.2				

Nama:

HUB

No. Assy:

Skala

2:1

Digambar

Diperiksa

Disahkan

1-8-22

Rendi

Radhi

Bayu



Politeknik Negeri Cilacap, Jurusan Teknik Mesin

Jl. Dr. Soetomo, No. 01, Sidakaya, Cilacap, 53212

Telp: 0282-533329, E-mail: tmpnc@politeknikcilacap.ac.id

Format

A4

Satuan

mm

4		3			2		1
No.	Perubahan	Tanggal	Nama	No.	Perubahan	Tanggal	Nama
△				△			

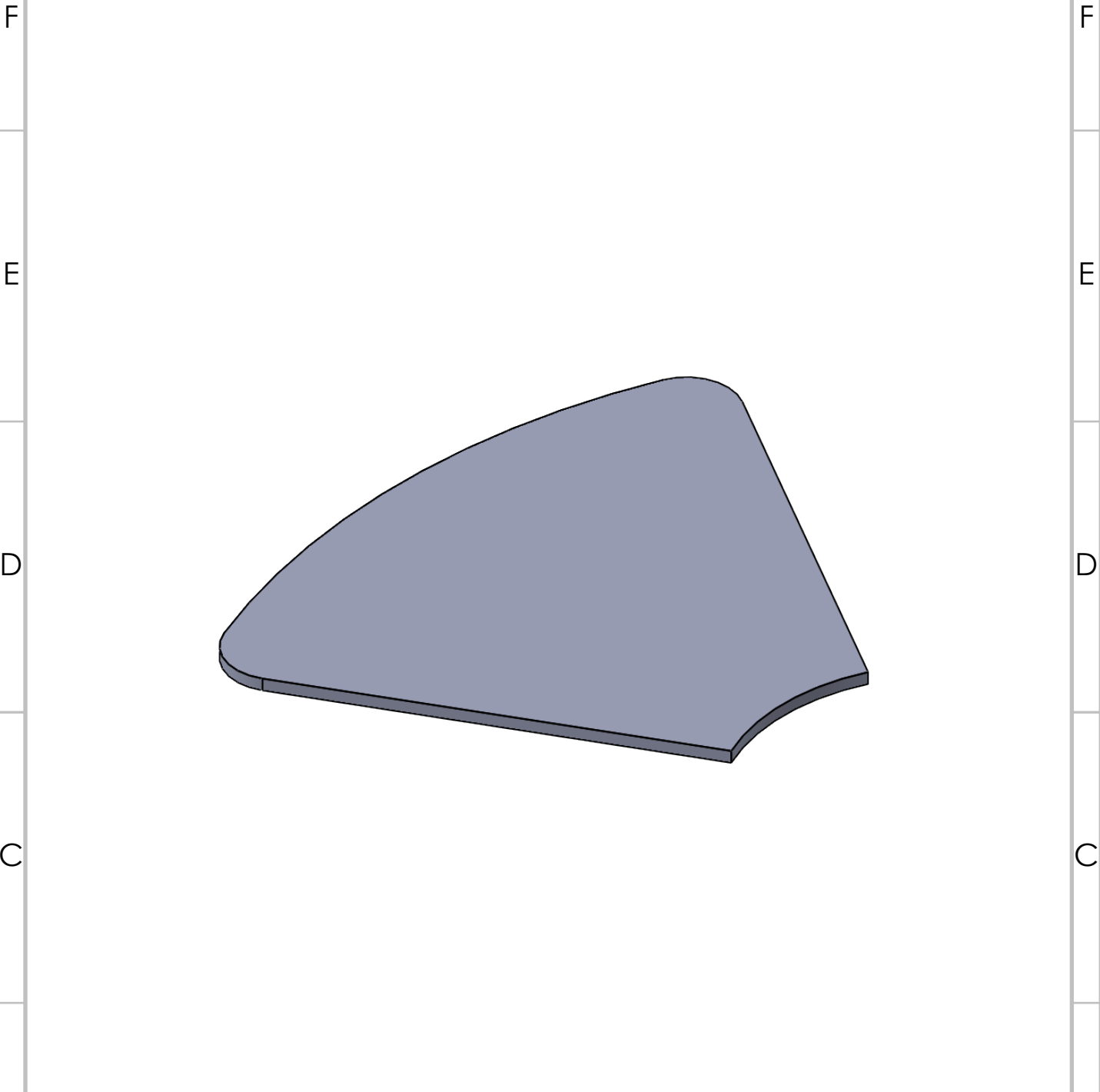

6	Blade	B2	Stainless 430	Lihat Detail	Dibuat
Jml	Nama Bagian	No.Id	Bahan	Ukuran	Keterangan
>	0 6 30 120 400 1000	Ukuran Lanjut:		No. Order:	Proyeksi:
<	6 30 120 400 1000 2000				
Tol	0.1 0.2 0.3 0.5 0.8 1.2				

Nama:			Skala 5:1	Digambar	1-8-22	Rendi
Blade				Diperiksa		Radhi
				Disahkan		Bayu
No. Assy:						

 Politeknik Negeri Cilacap, Jurusan Teknik Mesin Jl. Dr. Soetomo, No. 01, Sidakaya, Cilacap, 53212 Telp: 0282-533329, E-mail: tmpnc@politeknikcilacap.ac.id			Format A4	Satuan mm		
---	--	--	----------------------------	----------------------------	--	--

DILARANG MENGGANDAKAN, MENYALIN, MEMINDAH TANGKANKAN GAMBAR INI
TANPA IZIN TERTULIS DARI POLITEKNIK NEGERI CILACAP

DILARANG MENGGANDAKAN, MENYALIN, MEMINDAHTANGANKAN GAMBAR INI
TANPA IZIN TERTULIS DARI POLITEKNIK NEGERI CILACAP

	4		3		2		1
No.	Perubahan	Tanggal	Nama	No.	Perubahan	Tanggal	Nama
△				△			

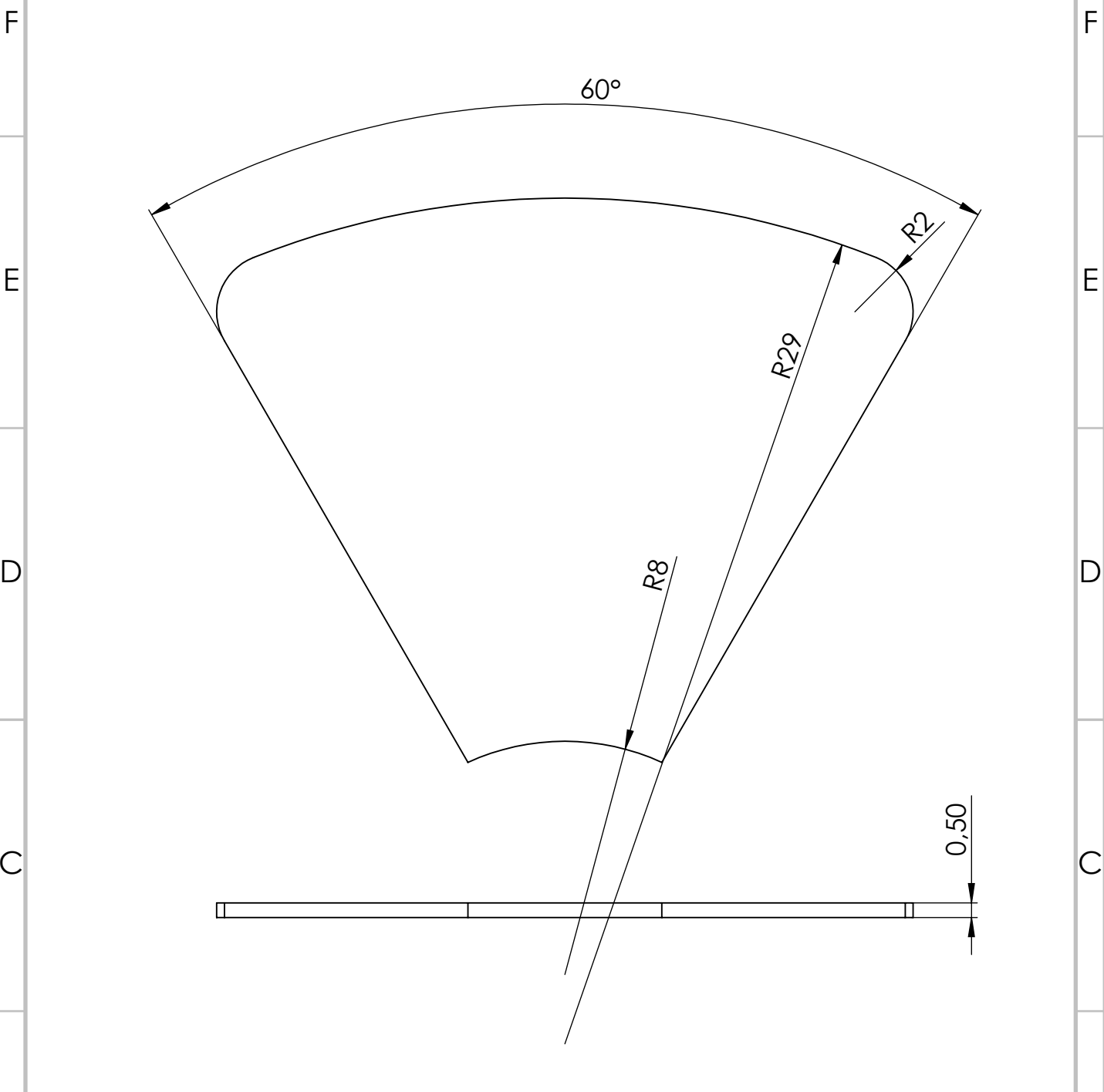

6	Blade						B2	Stainless 430	Lihat Detail	Dibuat
>	0	6	30	120	400	1000	Ukuran Lanjut:	No. Order:	Proyeksi:	
<	6	30	120	400	1000	2000				
Tol	0.1	0.2	0.3	0.5	0.8	1.2				

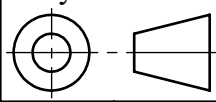

Nama: <div style="text-align: center; font-size: 24px; font-weight: bold;">Blade</div>	Skala	Digambar	1-8-22	Rendi
No. Assy:	5:1	Diperiksa		Radhi
		Disahkan		Bayu

Politeknik Negeri Cilacap, Jurusan Teknik Mesin Jl. Dr. Soetomo, No. 01, Sidakaya, Cilacap, 53212 Telp: 0282-533329, E-mail: tmpnc@politeknikcilacap.ac.id	Format	Satuan		
	A4	mm		

LAMPIRAN 10

Guide Vanes

4		3		2		1	
No.	Perubahan	Tanggal	Nama	No.	Perubahan	Tanggal	Nama
△				△			

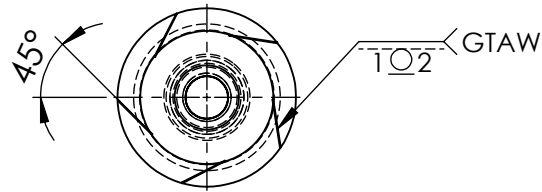

SECTION W-W

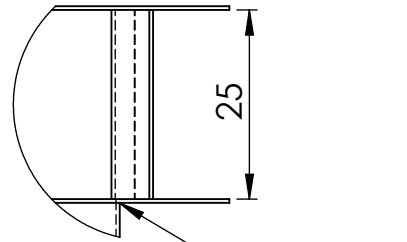
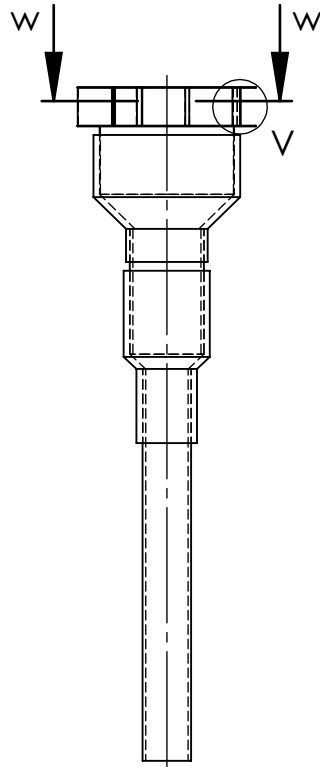

DETAIL V
SCALE 1 : 1

1	Pipa 8	C8	PVC	Lihat Detail	Dibeli
1	Pipa 7	C7	PVC	Lihat Detail	Dibeli
1	Shock Reducer 1.5x1 Inch	C6	PVC	Lihat Detail	Dibeli
1	Shock Reducer 3x1.5 Inch	C5	PVC	Lihat Detail	Dibeli
1	Draft Tube	C4	Stainless 430	Lihat Detail	Dibuat
1	Lower Cover	C3	Stainless 430	Lihat Detail	Dibuat
5	Stay Vane	C2	Stainless 430	Lihat Detail	Dibuat
1	Top Cover	C1	Stainless 430	Lihat Detail	Dibuat

B	Jml	Nama Bagian					No.Id	Bahan	Ukuran	Keterangan
	>	0	6	30	120	400	1000	Ukuran Lanjut:	No. Order:	Proyeksi:
	<	6	30	120	400	1000	2000			
	Tol	±0.1	±0.2	±0.3	±0.5	±0.8	±1.2			

Nama:

Sub Assembly Guide Vanes

No. Assy:

Skala 1:5	Digambar	1-8-22	Rendi
	Diperiksa		Radhi
	Disahkan		Bayu



Politeknik Negeri Cilacap, Jurusan Teknik Mesin
 Jl. Dr. Soetomo, No. 01, Sidakaya, Cilacap, 53212
 Telp: 0282-533329, E-mail: tmpnc@politeknikcilacap.ac.id

Format
A4

Satuan
mm

4		3		2		1	
No.	Perubahan	Tanggal	Nama	No.	Perubahan	Tanggal	Nama
△				△			

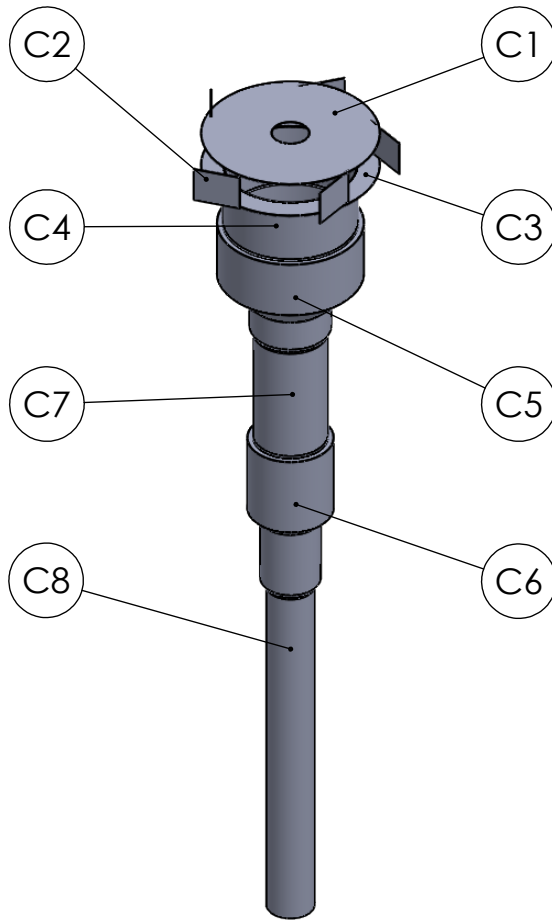

1	Pipa 8	C8	PVC	Lihat Detail	Dibeli
1	Pipa 7	C7	PVC	Lihat Detail	Dibeli
1	Shock Reducer 1.5x1 Inch	C6	PVC	Lihat Detail	Dibeli
1	Shock Reducer 3x1.5 Inch	C5	PVC	Lihat Detail	Dibeli
1	Draft Tube	C4	Stainless 430	Lihat Detail	Dibuat
1	Lower Cover	C3	Stainless 430	Lihat Detail	Dibuat
5	Stay Vane	C2	Stainless 430	Lihat Detail	Dibuat
1	Top Cover	C1	Stainless 430	Lihat Detail	Dibuat
Jml	Nama Bagian	No.Id	Bahan	Ukuran	Keterangan
>	0 6 30 120 400 1000	Ukuran Lanjut:		No. Order:	Proyeksi:
<	6 30 120 400 1000 2000				
Tol	±0.1 ±0.2 ±0.3 ±0.5 ±0.8 ±1.2				

Nama:		Skala 1:5	Digambar	1-8-22	Rendi
Sub Assembly Guide Vanes			Diperiksa		Radhi
			Disahkan		Bayu
No. Assy:		Format	Satuan		
 Politeknik Negeri Cilacap, Jurusan Teknik Mesin Jl. Dr. Soetomo, No. 01, Sidakaya, Cilacap, 53212 Telp: 0282-533329, E-mail: tmpnc@politeknikcilacap.ac.id		A4	mm		

4		3			2		1
No.	Perubahan	Tanggal	Nama	No.	Perubahan	Tanggal	Nama
△				△			

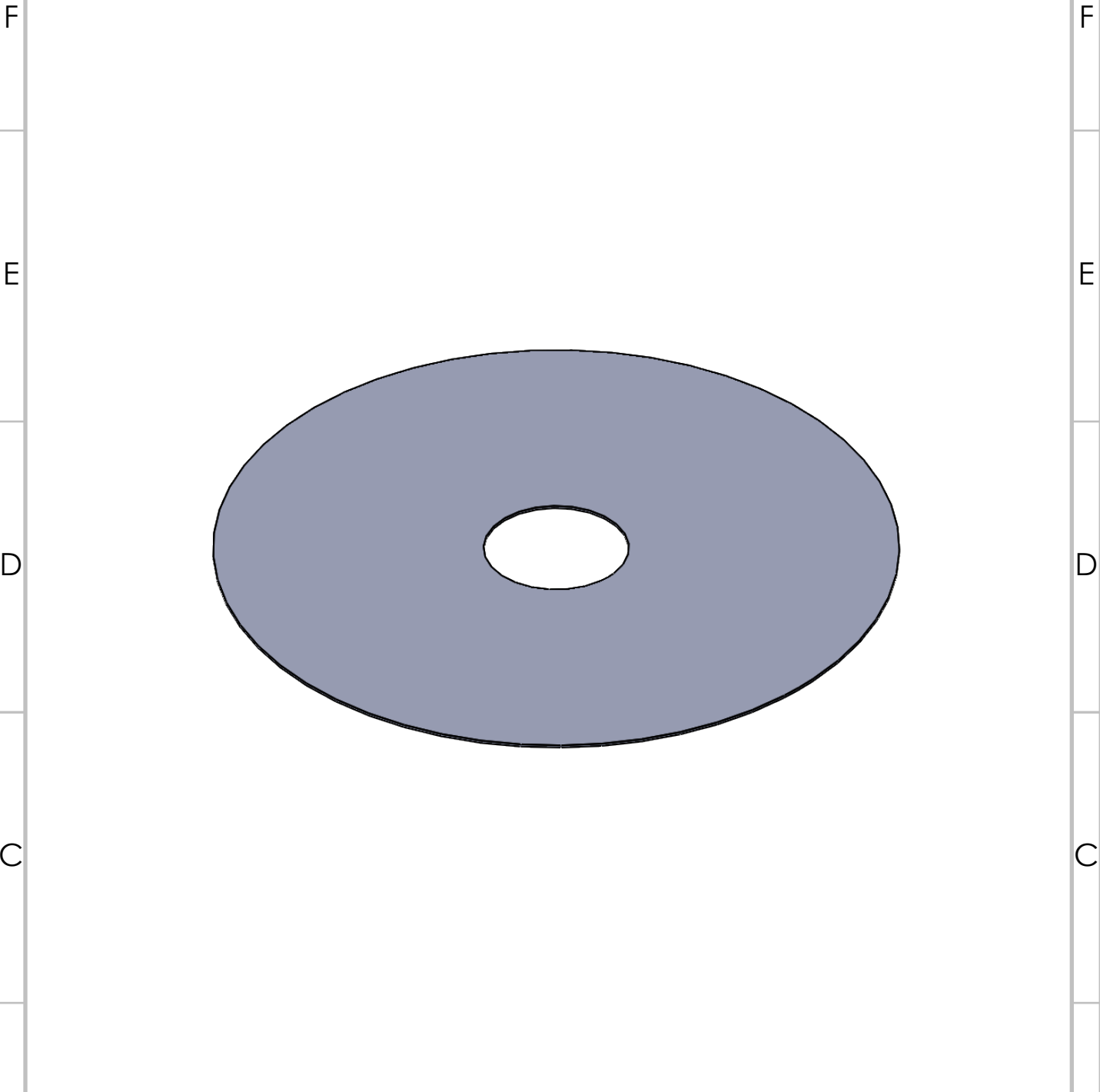

1	Top Cover	C1	Stainless 430	Lihat Detail	Dibuat
Jml	Nama Bagian	No.Id	Bahan	Ukuran	Keterangan
>	0 6 30 120 400 1000	Ukuran Lanjut:		No. Order:	Proyeksi:
<	6 30 120 400 1000 2000				
Tol	±0.1 ±0.2 ±0.3 ±0.5 ±0.8 ±1.2				

Nama:	TOP COVER	Skala 1:1	Digambar	1-8-22	Rendi
No. Assy:			Diperiksa		Radhi
			Disahkan		Bayu

 Politeknik Negeri Cilacap, Jurusan Teknik Mesin Jl. Dr. Soetomo, No. 01, Sidakaya, Cilacap, 53212 Telp: 0282-533329, E-mail: tmpnc@politeknikcilacap.ac.id	Format	Satuan		
	A4	mm		

DILARANG MENGGANDAKAN, MENYALIN, MEMINDAHKAN GAMBAR INI TANPA IZIN TERTULIS DARI POLITEKNIK NEGERI CILACAP

DILARANG MENGGANDAKAN, MENYALIN, MEMINDAHKAN GAMBAR INI TANPA IZIN TERTULIS DARI POLITEKNIK NEGERI CILACAP

	4	3	2	1
No.	Perubahan	Tanggal	Nama	No.
No.	Perubahan	Tanggal	Nama	No.

F
F

E
E

D
D

C
C

B
B

A
A

	1 Top Cover	C1	Stainless 430	Lihat Detail	Dibuat						
>	0	6	30	120	400	1000	Ukuran Lanjut:	No. Order:	Proyeksi:		
<	6	30	120	400	1000	2000					
Tol	± 0.1	± 0.2	± 0.3	± 0.5	± 0.8	± 1.2					
TOP COVER								Skala	Digambar	1-8-22	Rendi
Nama:								1:1	Diperiksa		Radhi
No. Assy:									Disahkan		Bayu
Politeknik Negeri Cilacap, Jurusan Teknik Mesin Jl. Dr. Soetomo, No. 01, Sidakaya, Cilacap, 53212 Telp: 0282-533329, E-mail: tmpnc@politeknikcilacap.ac.id									Format	Satuan	
								A4	mm		

PENGGANTI DARI:
DIGANTI DENGAN:

4		3			2		1
No.	Perubahan	Tanggal	Nama	No.	Perubahan	Tanggal	Nama
△				△			

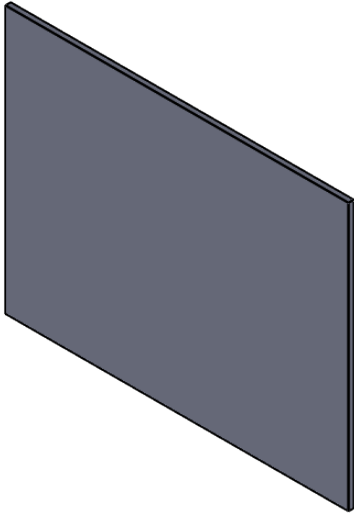
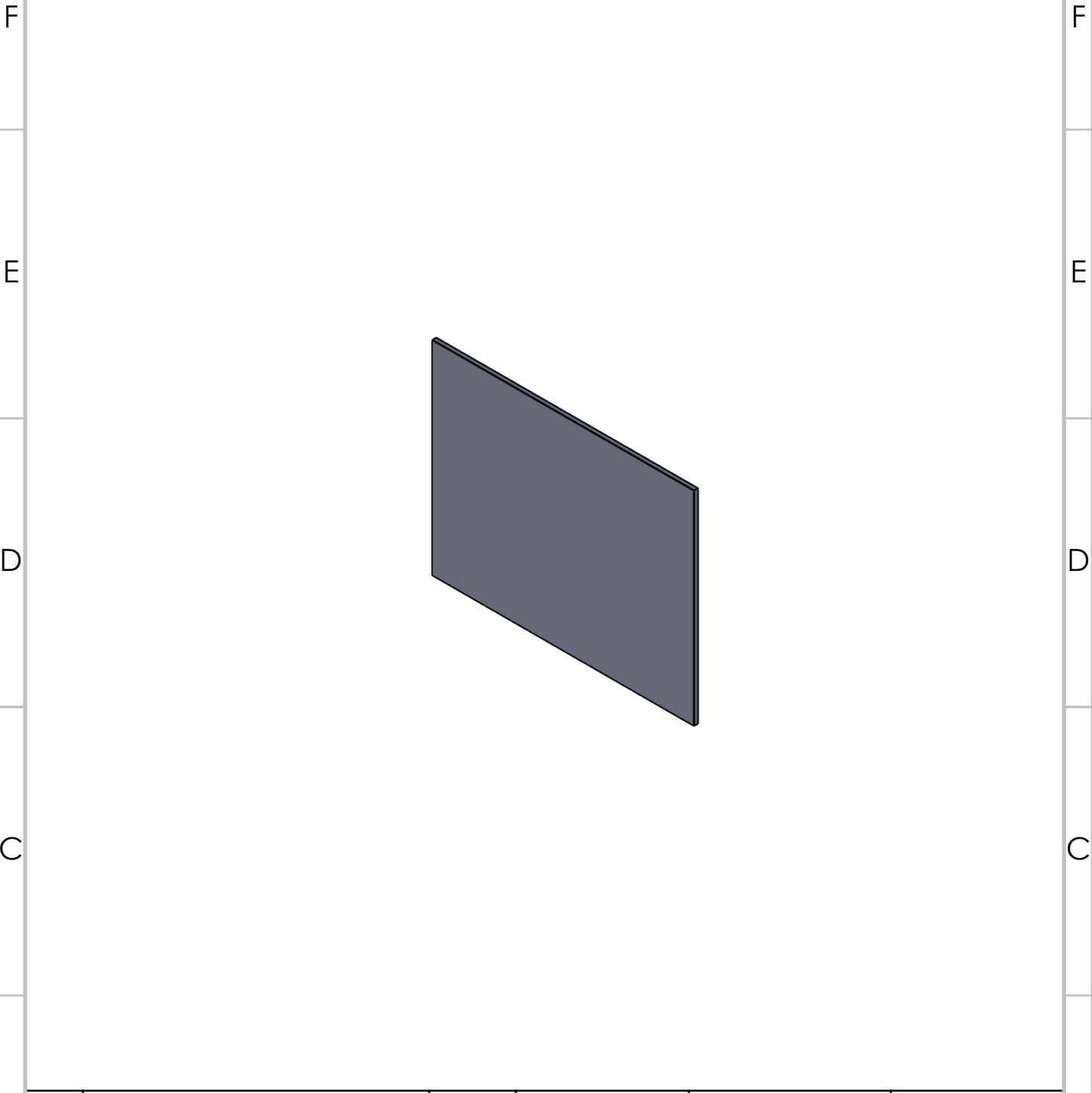



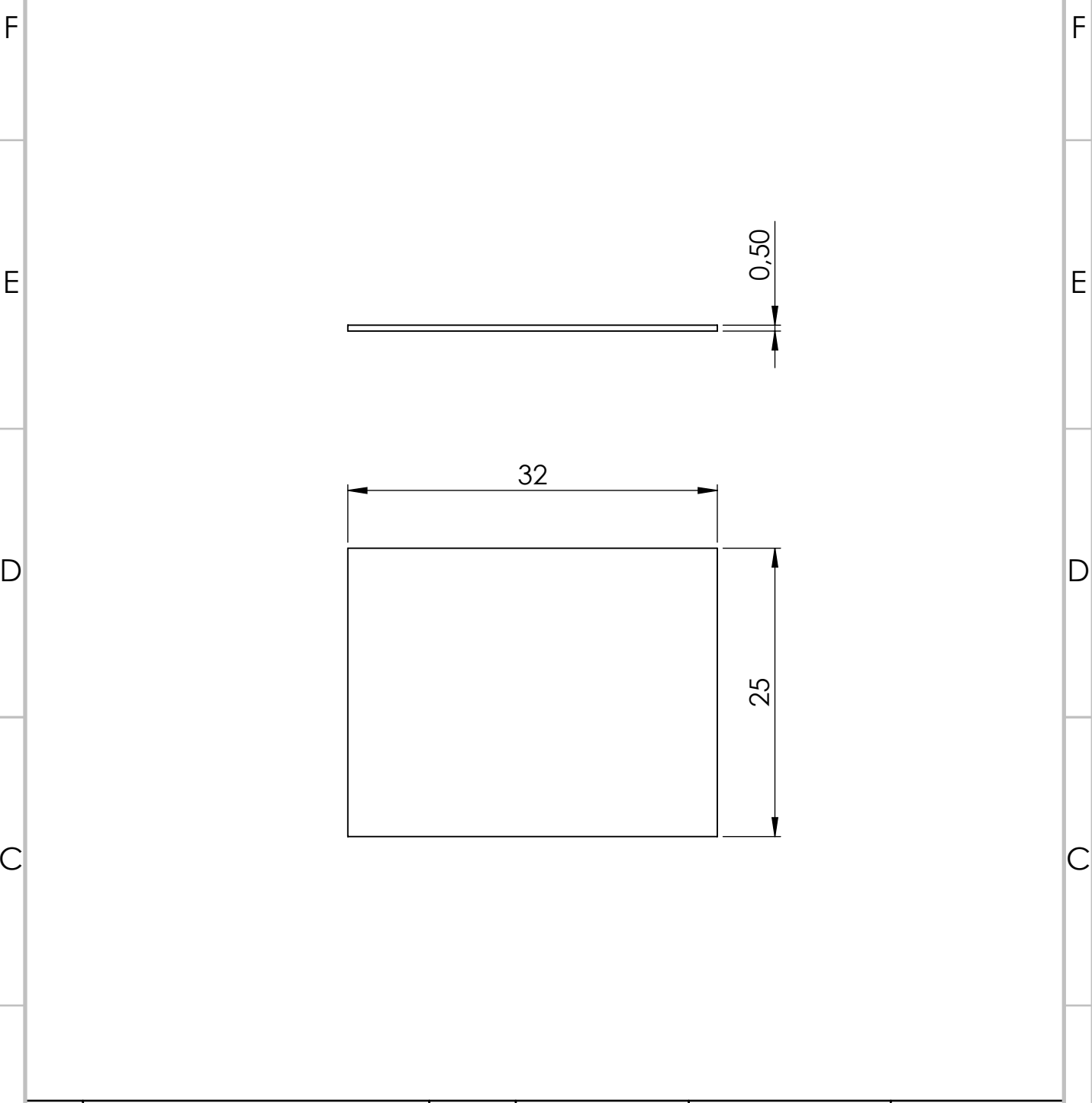

5	Stay Vane						C2	Stainless 430	Lihat Detail	Dibuat			
B	Jml	Nama Bagian					No.Id	Bahan	Ukuran	Keterangan			
	>	0	6	30	120	400	1000	Ukuran Lanjut:	No. Order:	Proyeksi:			
	<	6	30	120	400	1000	2000						
	Tol	±0.1	±0.2	±0.3	±0.5	±0.8	±1.2						
Nama:									Skala 2:1	Digambar	1-8-22	Rendi	
STAY VANE										Diperiksa		Radhi	
										Disahkan		Bayu	
A	No. Assy:												
 Politeknik Negeri Cilacap, Jurusan Teknik Mesin Jl. Dr. Soetomo, No. 01, Sidakaya, Cilacap, 53212 Telp: 0282-533329, E-mail: tmpnc@politeknikcilacap.ac.id									Format A4	Satuan mm			

4	3	2	1				
No.	Perubahan	Tanggal	Nama	No.	Perubahan	Tanggal	Nama
△				△			

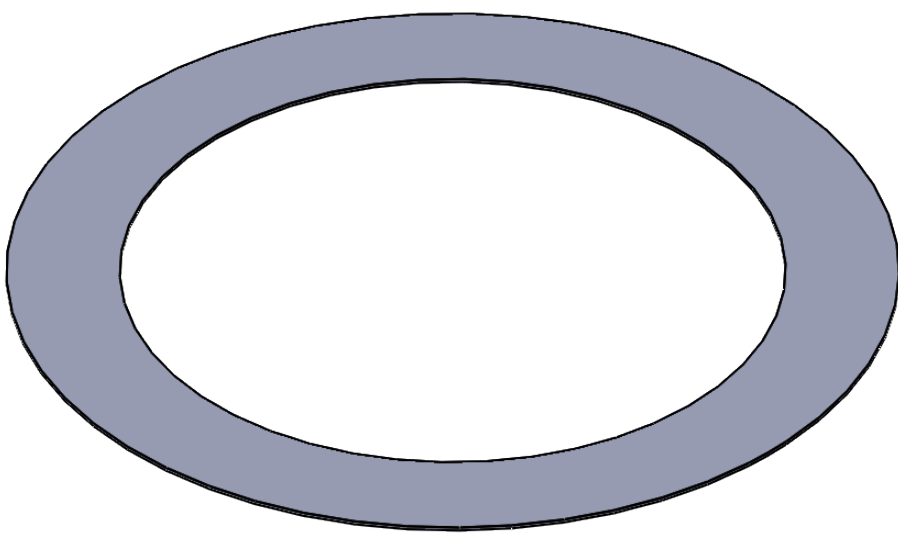

5	Stay Vane						C2	Stainless 430	Lihat Detail	Dibuat			
B	Jml	Nama Bagian						No.Id	Bahan	Ukuran	Keterangan		
	>	0	6	30	120	400	1000	Ukuran Lanjut:	No. Order:	Proyeksi:			
	<	6	30	120	400	1000	2000						
	Tol	±0.1	±0.2	±0.3	±0.5	±0.8	±1.2						
	Nama:								Skala 2:1	Digambar	1-8-22	Rendi	
	STAY VANE									Diperiksa		Radhi	
	No. Assy:									Disahkan		Bayu	
A													
	Politeknik Negeri Cilacap, Jurusan Teknik Mesin Jl. Dr. Soetomo, No. 01, Sidakaya, Cilacap, 53212 Telp: 0282-533329, E-mail: tmpnc@politeknikcilacap.ac.id								Format A4	Satuan mm			

DILARANG MENGGANDAKAN, MENYALIN, MEMINDAHKANKAN GAMBAR INI TANPA IZIN TERTULIS DARI POLITEKNIK NEGERI CILACAP

	4		3		2		1																																														
No.	Perubahan	Tanggal	Nama	No.	Perubahan	Tanggal	Nama																																														
△				△																																																	
F							F																																														
E							E																																														
D							D																																														
C							C																																														
B	<table border="1" style="width: 100%; border-collapse: collapse;"> <tr> <td style="width: 5%;">1</td> <td colspan="6">Lower Cover</td> <td style="width: 5%;">C3</td> <td style="width: 15%;">Stainless 430</td> <td style="width: 15%;">Lihat Detail</td> <td style="width: 15%;">Dibuat</td> </tr> <tr> <td>Jml</td> <td colspan="6">Nama Bagian</td> <td>No.Id</td> <td>Bahan</td> <td>Ukuran</td> <td>Keterangan</td> </tr> <tr> <td>></td> <td>0</td> <td>6</td> <td>30</td> <td>120</td> <td>400</td> <td>1000</td> <td rowspan="3">Ukuran Lanjut:</td> <td rowspan="3">No. Order:</td> <td rowspan="3">Proyeksi:</td> </tr> <tr> <td><</td> <td>6</td> <td>30</td> <td>120</td> <td>400</td> <td>1000</td> <td>2000</td> </tr> <tr> <td>Tol</td> <td>±0.1</td> <td>±0.2</td> <td>±0.3</td> <td>±0.5</td> <td>±0.8</td> <td>±1.2</td> </tr> </table>						1	Lower Cover						C3	Stainless 430	Lihat Detail	Dibuat	Jml	Nama Bagian						No.Id	Bahan	Ukuran	Keterangan	>	0	6	30	120	400	1000	Ukuran Lanjut:	No. Order:	Proyeksi:	<	6	30	120	400	1000	2000	Tol	±0.1	±0.2	±0.3	±0.5	±0.8	±1.2	B
1	Lower Cover						C3	Stainless 430	Lihat Detail	Dibuat																																											
Jml	Nama Bagian						No.Id	Bahan	Ukuran	Keterangan																																											
>	0	6	30	120	400	1000	Ukuran Lanjut:	No. Order:	Proyeksi:																																												
<	6	30	120	400	1000	2000																																															
Tol	±0.1	±0.2	±0.3	±0.5	±0.8	±1.2																																															
A	<p>Nama: Skala Digambar 1-8-22 Rendi</p> <p style="text-align: center; font-size: 2em;">LOWER COVER</p> <p>No. Assy: 1:1 Diperiksa Radhi</p> <p style="float: right;">Disahkan Bayu</p>						A																																														
<table border="1" style="width: 100%; border-collapse: collapse;"> <tr> <td style="width: 15%; text-align: center;"></td> <td style="width: 50%;"> Politeknik Negeri Cilacap, Jurusan Teknik Mesin Jl. Dr. Soetomo, No. 01, Sidakaya, Cilacap, 53212 Telp: 0282-533329, E-mail: tmpnc@politeknikcilacap.ac.id </td> <td style="width: 15%; text-align: center;">Format A4</td> <td style="width: 10%; text-align: center;">Satuan mm</td> </tr> </table>									Politeknik Negeri Cilacap, Jurusan Teknik Mesin Jl. Dr. Soetomo, No. 01, Sidakaya, Cilacap, 53212 Telp: 0282-533329, E-mail: tmpnc@politeknikcilacap.ac.id	Format A4	Satuan mm	1																																									
	Politeknik Negeri Cilacap, Jurusan Teknik Mesin Jl. Dr. Soetomo, No. 01, Sidakaya, Cilacap, 53212 Telp: 0282-533329, E-mail: tmpnc@politeknikcilacap.ac.id	Format A4	Satuan mm																																																		
4	3	2	1																																																		

PENGGANTI DARI:

DIGANTI DENGAN

DILARANG MENGGANDAKAN, MENYALIN, MEMINDAHTANGANKAN GAMBAR INI
TANPA IZIN TERTULIS DARI POLITEKNIK NEGERI CILACAP

4		3		2		1	
No.	Perubahan	Tanggal	Nama	No.	Perubahan	Tanggal	Nama
△				△			

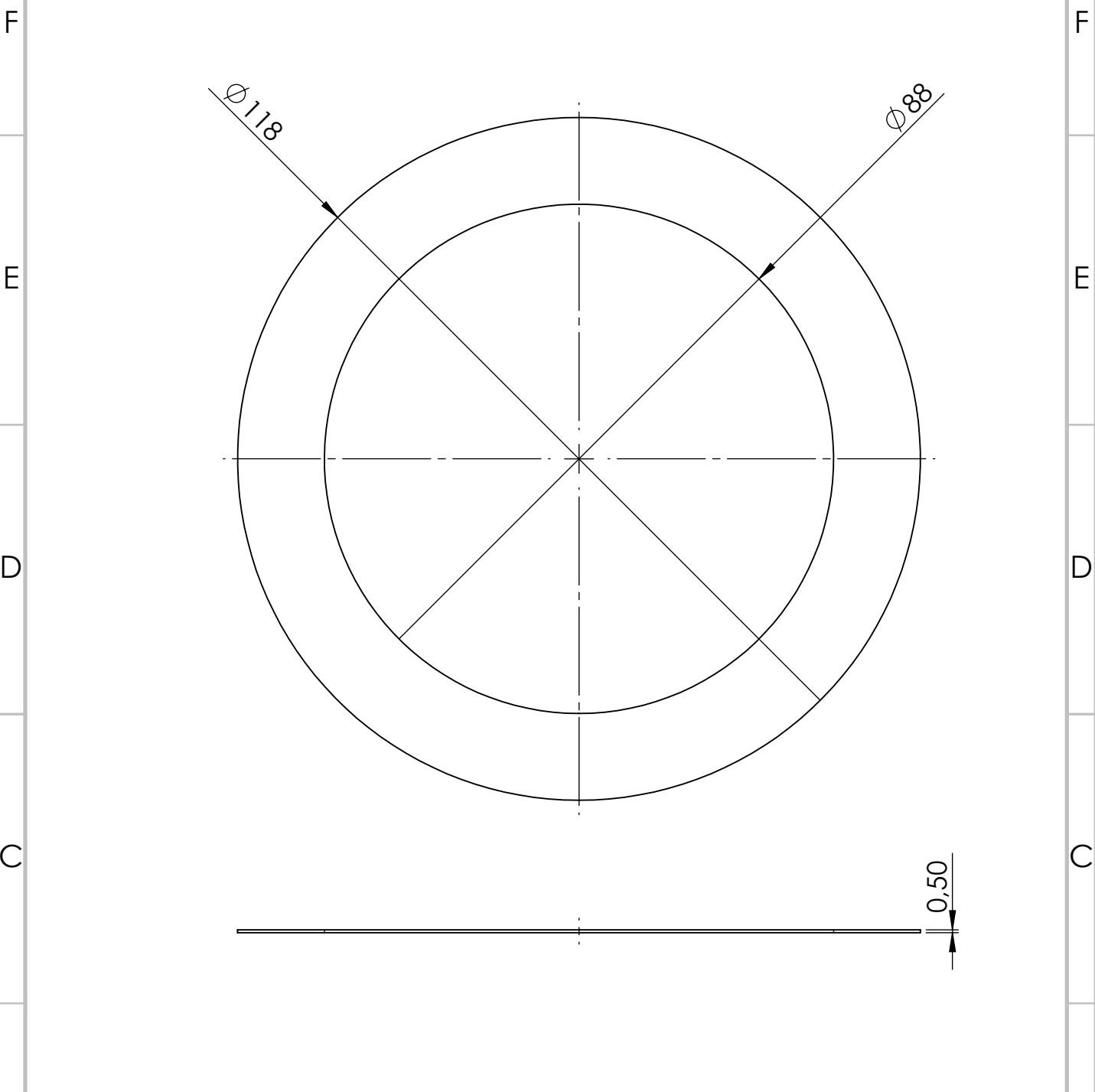

1	Lower Cover	C3	Stainless 430	Lihat Detail	Dibuat		
>	0	6	30	120	400	1000	
<	6	30	120	400	1000	2000	
Tol	±0.1	±0.2	±0.3	±0.5	±0.8	±1.2	
Ukuran Lanjut:				No. Order:	Proyeksi:		
Nama:				Skala	Digambar	1-8-22	Rendi
LOWER COVER				1:1	Diperiksa		Radhi
No. Assy:				Disahkan			Bayu
Politeknik Negeri Cilacap, Jurusan Teknik Mesin Jl. Dr. Soetomo, No. 01, Sidakaya, Cilacap, 53212 Telp: 0282-533329, E-mail: tmpnc@politeknikcilacap.ac.id				Format	Satuan		
				A4	mm		

4

3

2

1

No.	Perubahan	Tanggal	Nama	No.	Perubahan	Tanggal	Nama
△				△			

F

F

E

E

D

D

C

C

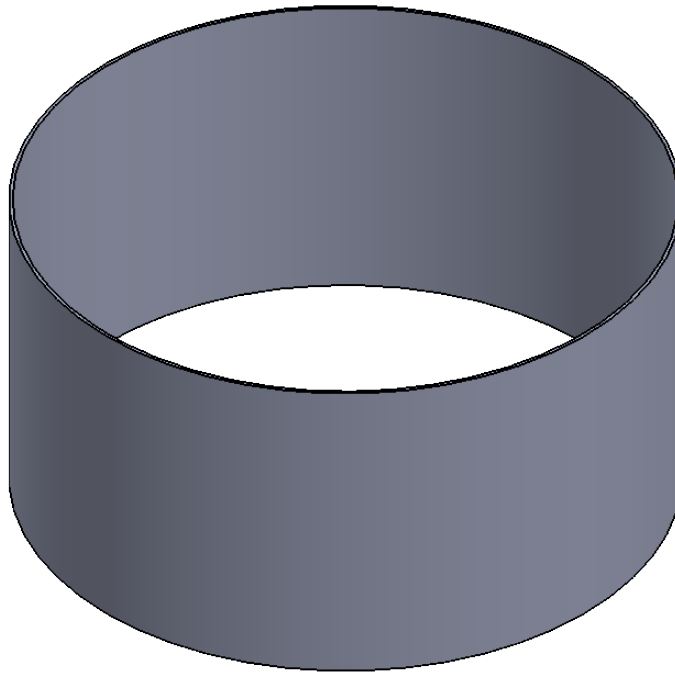

B

B

1	Draft Tube						C4	Stainless 430	Lihat Detail	Dibuat
Jml	Nama Bagian						No.Id	Bahan	Ukuran	Keterangan
>	0	6	30	120	400	1000	Ukuran Lanjut:	No. Order:	Proyeksi:	
<	6	30	120	400	1000	2000				
Tol	±0.1	±0.2	±0.3	±0.5	±0.8	±1.2				

A

A

Nama:

DRAFT TUBE

No. Assy:

Skala

1:1

Digambar

Diperiksa

Disahkan

1-8-22

Rendi

Radhi

Bayu



Politeknik Negeri Cilacap, Jurusan Teknik Mesin

Jl. Dr. Soetomo, No. 01, Sidakaya, Cilacap, 53212

Telp: 0282-533329, E-mail: tmpnc@politeknikcilacap.ac.id

Format

A4

Satuan

mm

4

3

2

1

PENGANTI DARI:

DIGANTI DENGAN

DILARANG MENGGANDAKAN, MENYALIN, MEMINDAHKANGAMBAR INI
TANPA IZIN TERTULIS DARI POLITEKNIK NEGERI CILACAP

	4	3	2	
No.	Perubahan	Tanggal	Nama	No.
△				△
No.	Perubahan	Tanggal	Nama	

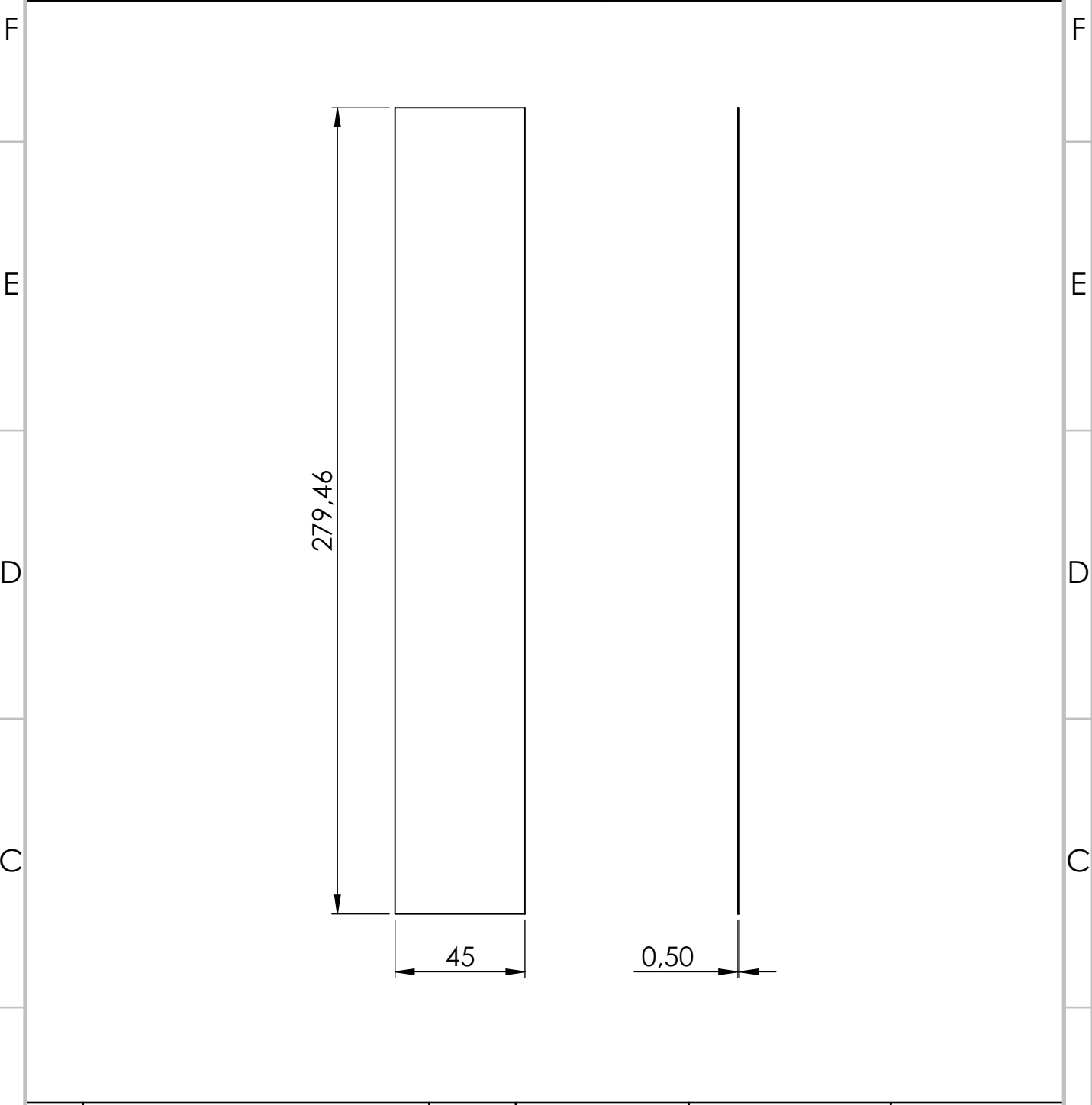

1	Draft Tube	C4	Stainless 430	Lihat Detail	Dibuat
>	0 6 30 120 400 1000	No.Id	Bahan	Ukuran	Keterangan
<	6 30 120 400 1000 2000	Ukuran Lanjut:		No. Order:	Proyeksi:
Tol	±0.1 ±0.2 ±0.3 ±0.5 ±0.8 ±1.2				

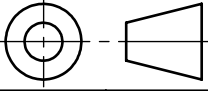

Nama:	1:2	Digambar	1-8-22	Rendi
DRAFT TUBE		Diperiksa		Radhi
		Disahkan		Bayu

No. Assy:	Format	Satuan		
	A4	mm		

	4	3	2	
--	---	---	---	--

DILARANG MENGGANDAKAN, MENYALIN, MEMINDAHTANGKAN GAMBAR INI
TANPA IZIN TERTULIS DARI POLITEKNIK NEGERI CILACAP

4			3			2			1
No.	Perubahan	Tanggal	Nama	No.	Perubahan	Tanggal	Nama		
△				△					

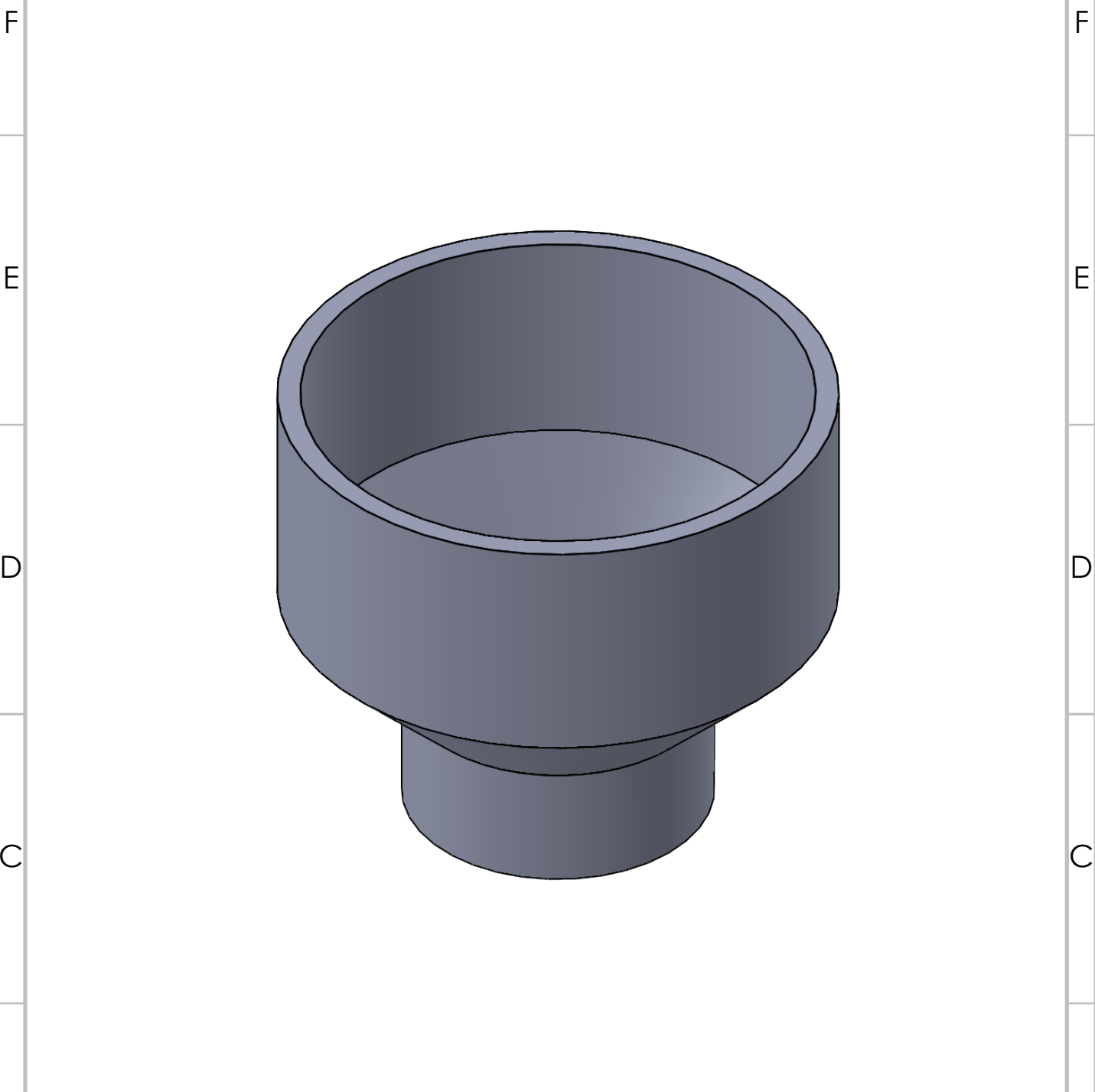

1	Shock Reducer 3x1.5 Inchi					C5	PVC	Lihat Detail	Dibeli
Jml	Nama Bagian					No.Id	Bahan	Ukuran	Keterangan
>	0	6	30	120	400	1000	Ukuran Lanjut:	No. Order:	Proyeksi:
<	6	30	120	400	1000	2000			
Tol	±0.1	±0.2	±0.3	±0.5	±0.8	±1.2			

Nama:							Skala 1:1	Digambar	1-8-22	Rendi
SHOCK REDUCER 3X1.5 INCI								Diperiksa		Radhi
								Disahkan		Bayu
No. Assy:										

	Politeknik Negeri Cilacap, Jurusan Teknik Mesin						Format A4	Satuan mm		
	Jl. Dr. Soetomo, No. 01, Sidakaya, Cilacap, 53212 Telp: 0282-533329, E-mail: tmpnc@politeknikcilacap.ac.id									

DILARANG MENGGANDAKAN, MENYALIN, MEMINDAHKAN GAMBAR INI TANPA IZIN TERTULIS DARI POLITEKNIK NEGERI CILACAP

4			3			2		1
No.	Perubahan	Tanggal	Nama	No.	Perubahan	Tanggal	Nama	
△				△				

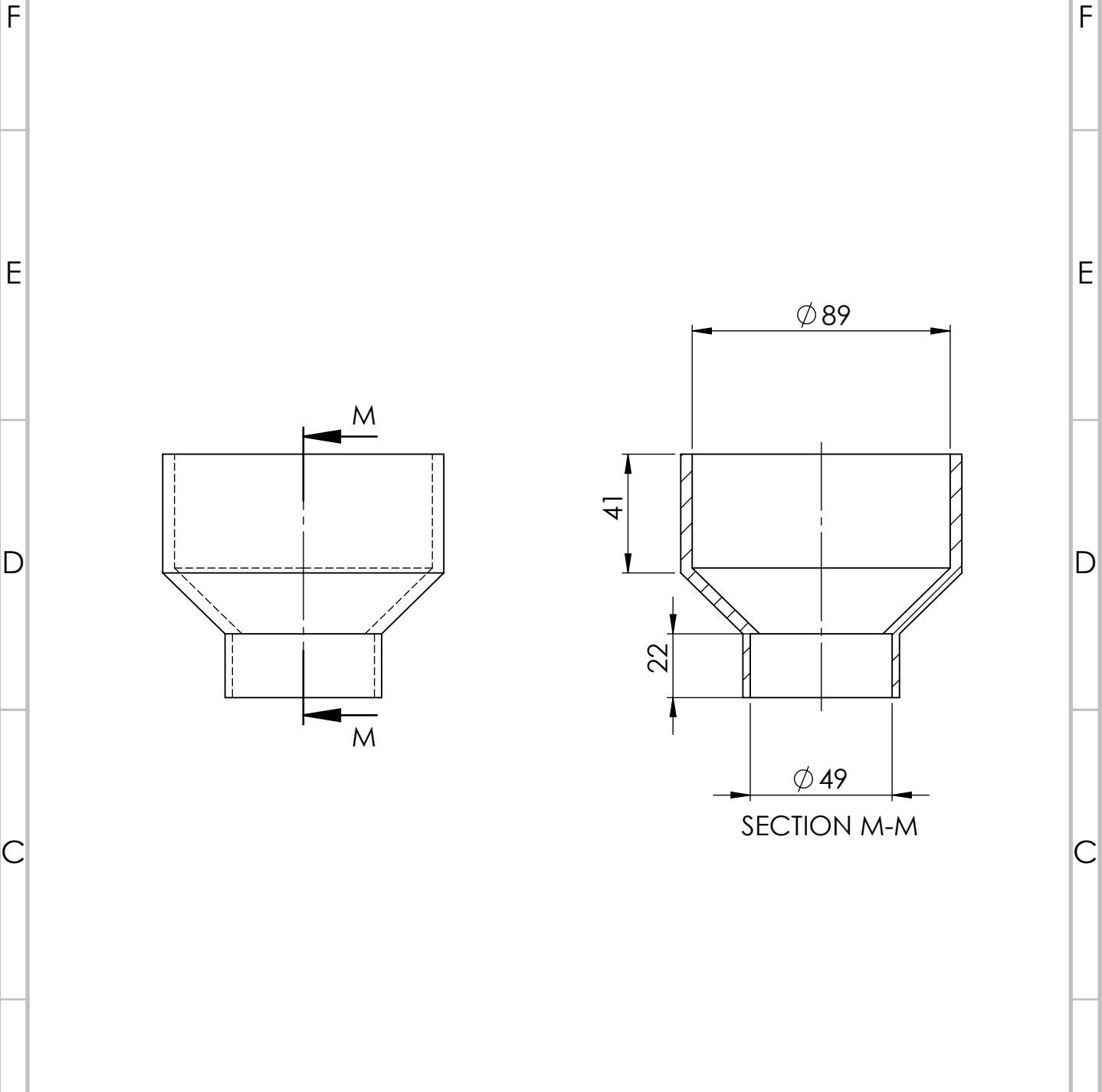

1	Shock Reducer 3x1.5 Inchi						C5	PVC	Lihat Detail	Dibeli
Jml	Nama Bagian						No.Id	Bahan	Ukuran	Keterangan
>	0	6	30	120	400	1000	Ukuran Lanjut:	No. Order:	Proyeksi:	
<	6	30	120	400	1000	2000				
Tol	±0.1	±0.2	±0.3	±0.5	±0.8	±1.2				

Nama:								Skala 1:2	Digambar	1-8-22	Rendi
SHOCK REDUCER 3X1.5 INCI									Diperiksa		Radhi
									Disahkan		Bayu
No. Assy:											

 Politeknik Negeri Cilacap, Jurusan Teknik Mesin Jl. Dr. Soetomo, No. 01, Sidakaya, Cilacap, 53212 Telp: 0282-533329, E-mail: tmpnc@politeknikcilacap.ac.id								Format A4	Satuan mm		
---	--	--	--	--	--	--	--	--------------	--------------	--	--

DILARANG MENGGANDAKAN, MENYALIN, MEMINDAHKAN GAMBAR INI TANPA IZIN TERTULIS DARI POLITEKNIK NEGERI CILACAP

	4	3	2	1			
No.	Perubahan	Tanggal	Nama	No.	Perubahan	Tanggal	Nama
△				△			

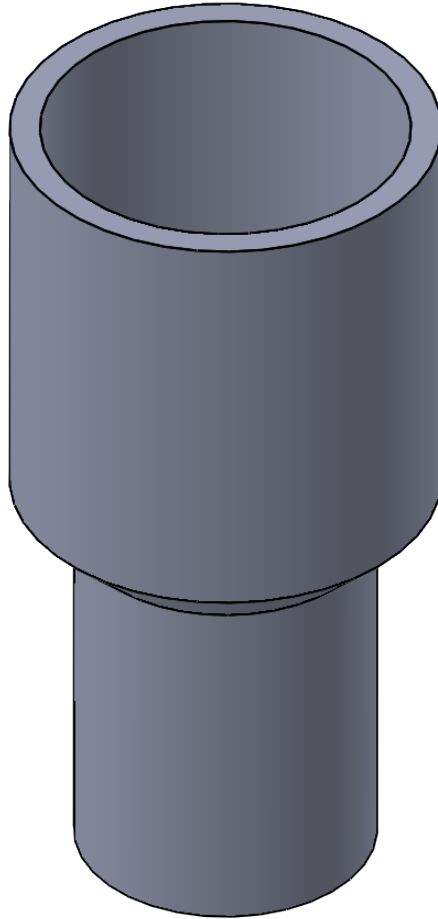

1	Shock Reducer 1.5x1 Inchi						C6	PVC	Lihat Detail	Dibeli
B	Jml	Nama Bagian					No.Id	Bahan	Ukuran	Keterangan
	>	0	6	30	120	400	1000	Ukuran Lanjut:	No. Order:	Proyeksi:
	<	6	30	120	400	1000	2000			
	Tol	±0.1	±0.2	±0.3	±0.5	±0.8	±1.2			

Nama:	Skala	Digambar	1-8-22	Rendi
SHOCK REDUCER 1.5X1 INCI	1:1	Diperiksa		Radhi
		Disahkan		Bayu
No. Assy:				

	Politeknik Negeri Cilacap, Jurusan Teknik Mesin	Format	Satuan	
	Jl. Dr. Soetomo, No. 01, Sidakaya, Cilacap, 53212 Telp: 0282-533329, E-mail: tmpnc@politeknikcilacap.ac.id	A4	mm	

DILARANG MENGGANDAKAN, MENYALIN, MEMINDAHTANGKAN GAMBAR INI
TANPA IZIN TERTULIS DARI POLITEKNIK NEGERI CILACAP

4		3		2		1	
No.	Perubahan	Tanggal	Nama	No.	Perubahan	Tanggal	Nama
△				△			

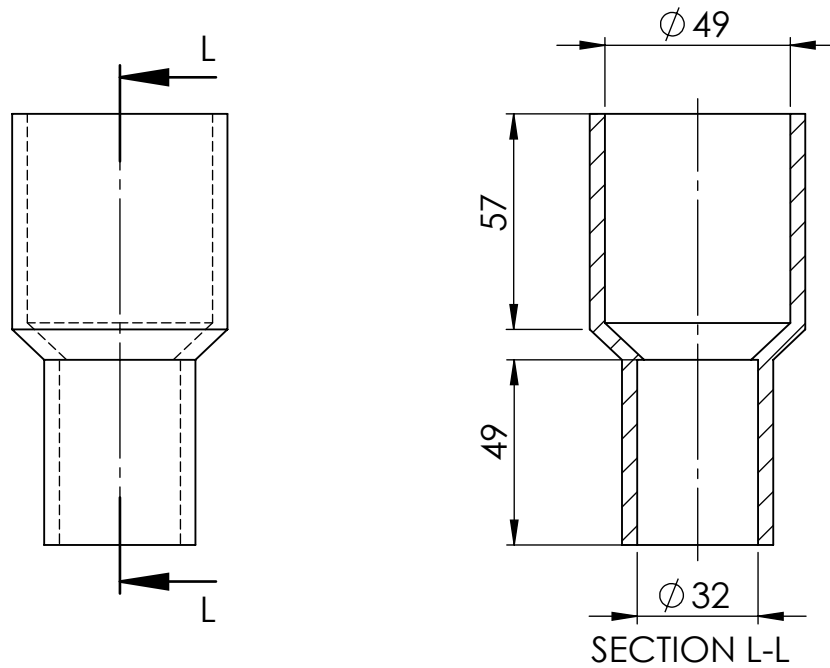

1	Shock Reducer 1.5x1 Inchi					C6	PVC	Lihat Detail	Dibeli		
B	Jml	Nama Bagian					No.Id	Bahan	Ukuran	Keterangan	
	>	0	6	30	120	400	1000	Ukuran Lanjut:	No. Order:	Proyeksi:	
	<	6	30	120	400	1000	2000				
	Tol	±0.1	±0.2	±0.3	±0.5	±0.8	±1.2				

Nama:

SHOCK REDUCER 1.5X1 INCI

No. Assy:

Skala 1:2	Digambar	1-8-22	Rendi
	Diperiksa		Radhi
	Disahkan		Bayu



Politeknik Negeri Cilacap, Jurusan Teknik Mesin

Jl. Dr. Soetomo, No. 01, Sidakaya, Cilacap, 53212
Telp: 0282-533329, E-mail: tmpnc@politeknikcilacap.ac.id

Format
A4

Satuan
mm

DILARANG MENGGANDAKAN, MENYALIN, MEMINDAHKAN GAMBAR INI
TANPA IZIN TERTULIS DARI POLITEKNIK NEGERI CILACAP

4				3			2		1
No.	Perubahan		Tanggal	Nama	No.	Perubahan		Tanggal	Nama
△					△				

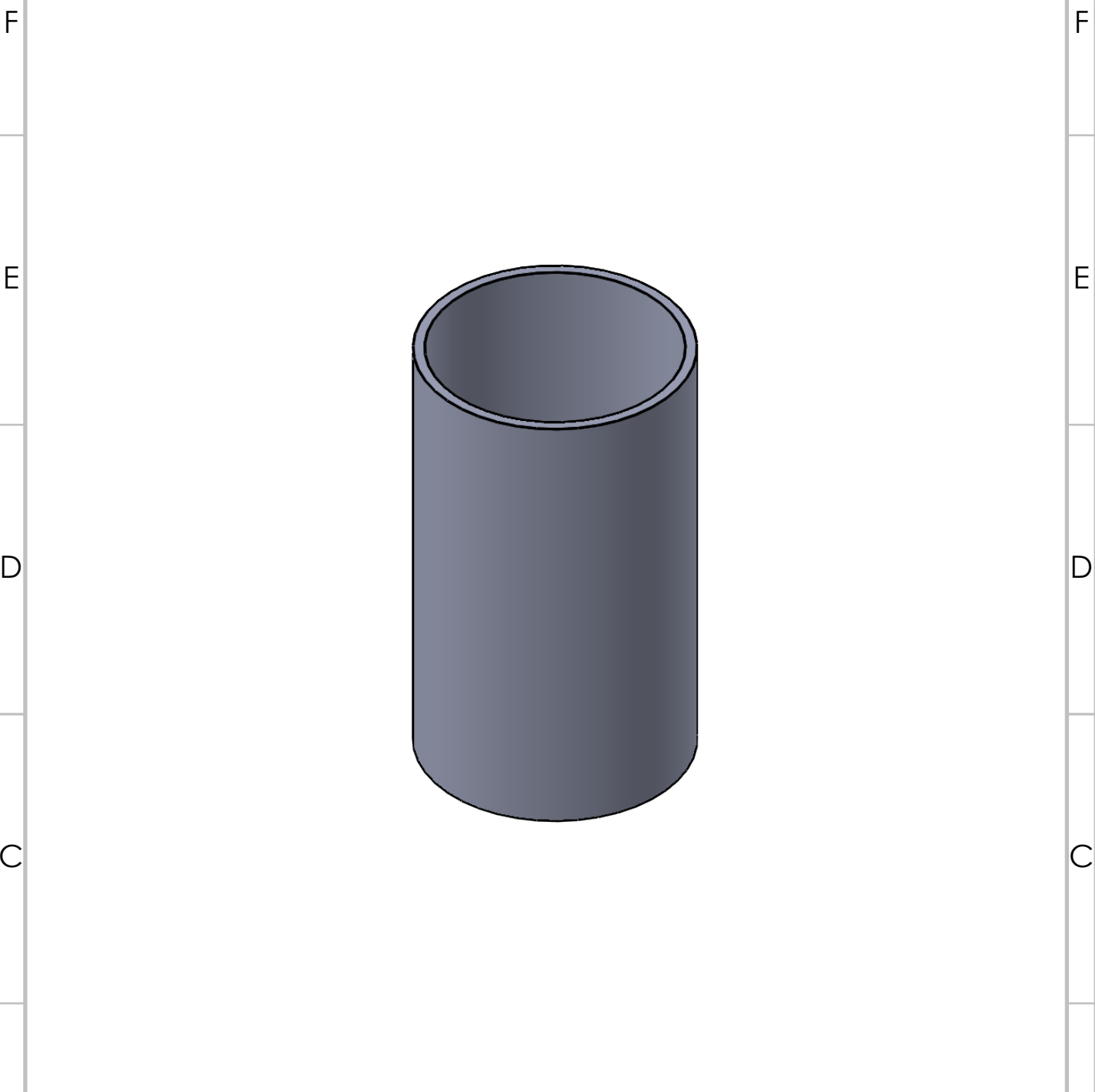

1	Pipa 7						C7	PVC	Lihat Detail	Dibeli		
B	Jml	Nama Bagian					No.Id	Bahan	Ukuran	Keterangan		
	>	0	6	30	120	400	1000	Ukuran Lanjut:	No. Order:	Proyeksi:		
	<	6	30	120	400	1000	2000					
	Tol	±0.1	±0.2	±0.3	±0.5	±0.8	±1.2					

Nama:								Skala 1:1	Digambar	1-8-22	Rendi
PIPA 7									Diperiksa		Radhi
									Disahkan		Bayu
No. Assy:											

 Politeknik Negeri Cilacap, Jurusan Teknik Mesin Jl. Dr. Soetomo, No. 01, Sidakaya, Cilacap, 53212 Telp: 0282-533329, E-mail: tmpnc@politeknikcilacap.ac.id								Format A4	Satuan mm		
---	--	--	--	--	--	--	--	---------------------	---------------------	--	--

DILARANG MENGGANDAKAN, MENYALIN, MEMINDAHTANGKAN GAMBAR INI
TANPA IZIN TERTULIS DARI POLITEKNIK NEGERI CILACAP

4	3	2	1
No.	Perubahan	Tanggal	Nama
No.	Perubahan	Tanggal	Nama

F

E

D

C

F

E

D

C

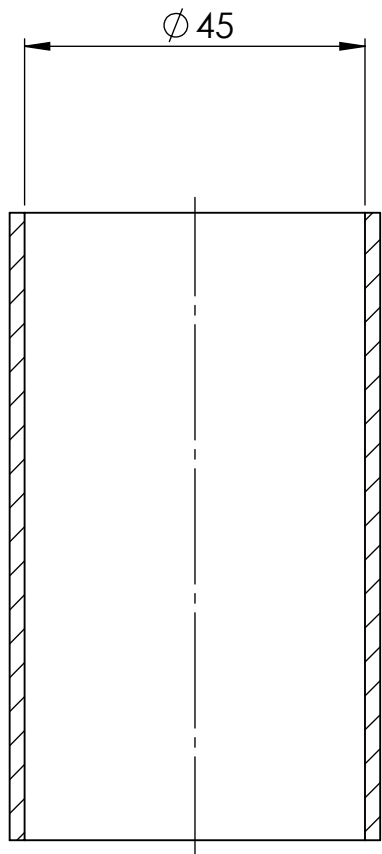
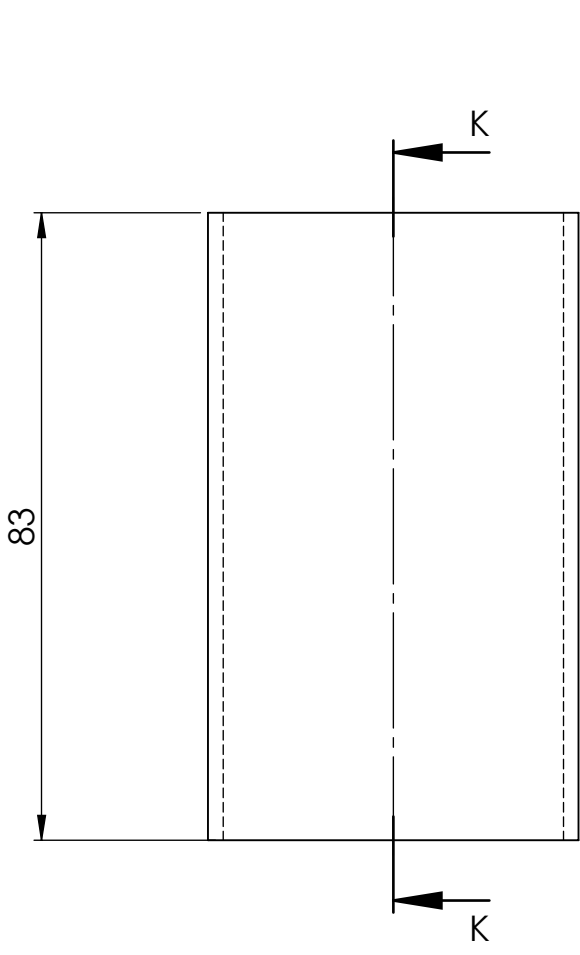

1	Pipa 7	C7	PVC	Lihat Detail	Dibeli
B	Jml Nama Bagian	No.Id	Bahan	Ukuran	Keterangan
	> 0 6 30 120 400 1000	Ukuran Lanjut:		No. Order:	Proyeksi:
	< 6 30 120 400 1000 2000				
	Tol ±0.1 ±0.2 ±0.3 ±0.5 ±0.8 ±1.2				
A	Nama: <h2 style="text-align: center;">PIPA 7</h2> No. Assy:			Skala <h3 style="text-align: center;">1:1</h3>	Digambar 1-8-22 Diperiksa Disahkan Rendi Radhi Bayu
	Politeknik Negeri Cilacap, Jurusan Teknik Mesin Jl. Dr. Soetomo, No. 01, Sidakaya, Cilacap, 53212 Telp: 0282-533329, E-mail: tmpnc@politeknikcilacap.ac.id			Format <h3 style="text-align: center;">A4</h3>	Satuan <h3 style="text-align: center;">mm</h3>

A

4

3

2

1

PENGGANTI DARI:

DIGANTI DENGAN

DILARANG MENGGANDAKAN, MENYALIN, MEMINDAHTANGKAN GAMBAR INI
TANPA IZIN TERTULIS DARI POLITEKNIK NEGERI CILACAP

	4	3	2	1
No.	Perubahan	Tanggal	Nama	No.
△				△

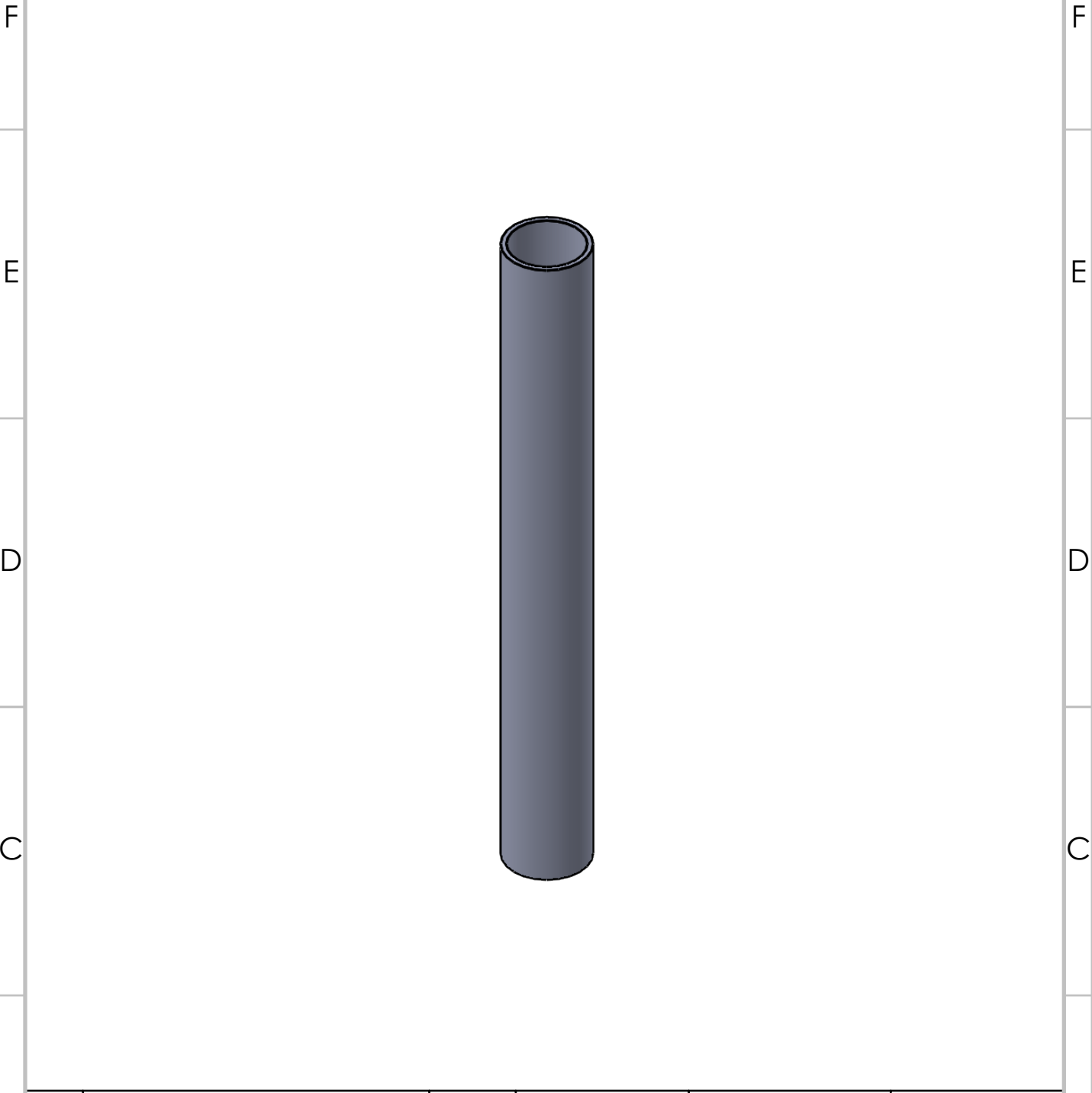

1	Pipa 8						C8	PVC	Lihat Detail	Dibeli		
B	Jml Nama Bagian						No.Id	Bahan	Ukuran	Keterangan		
	>	0	6	30	120	400	1000	Ukuran Lanjut:	No. Order:	Proyeksi:		
	<	6	30	120	400	1000	2000					
	Tol	±0.1	±0.2	±0.3	±0.5	±0.8	±1.2					
A	Nama: PIPA 8								Skala 1:1	Digambar	1-8-22	Rendi
	No. Assy:									Diperiksa		Radhi
										Disahkan		Bayu
	Politeknik Negeri Cilacap, Jurusan Teknik Mesin Jl. Dr. Soetomo, No. 01, Sidakaya, Cilacap, 53212 Telp: 0282-533329, E-mail: tmpnc@politeknikcilacap.ac.id								Format A4	Satuan mm		

4

3

2

1

No.	Perubahan	Tanggal	Nama	No.	Perubahan	Tanggal	Nama
△				△			

F

F

E

E

D

D

C

C

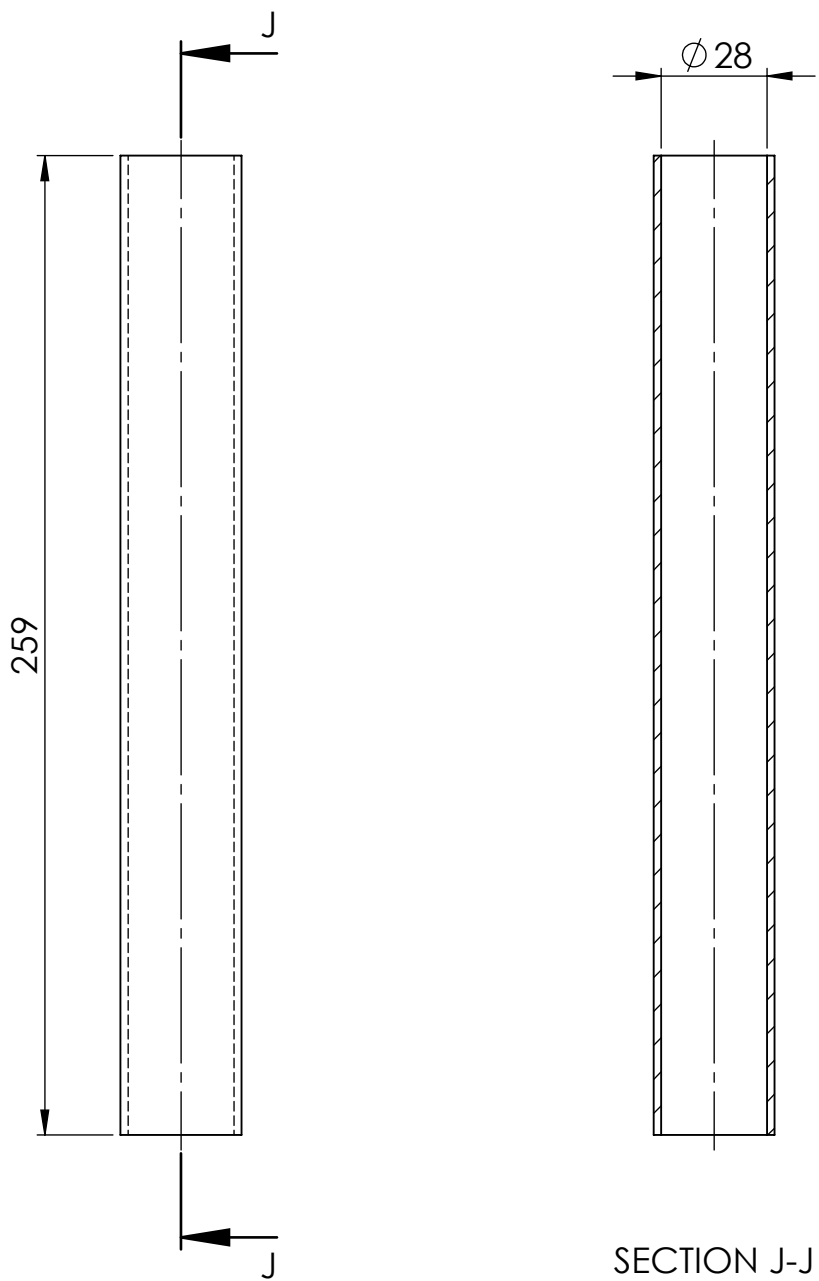

SECTION J-J

1	Pipa 8						C8	PVC	Lihat Detail	Dibeli			
B	Jml	Nama Bagian					No.Id	Bahan	Ukuran	Keterangan			
	>	0	6	30	120	400	1000	Ukuran Lanjut:	No. Order:	Proyeksi:			
	<	6	30	120	400	1000	2000						
	Tol	±0.1	±0.2	±0.3	±0.5	±0.8	±1.2						

Nama:								Skala 1:1	Digambar	1-8-22	Rendi
PIPA 8									Diperiksa		Radhi
									Disahkan		Bayu
No. Assy:											

 Politeknik Negeri Cilacap, Jurusan Teknik Mesin Jl. Dr. Soetomo, No. 01, Sidakaya, Cilacap, 53212 Telp: 0282-533329, E-mail: tmpnc@politeknikcilacap.ac.id								Format A4	Satuan mm		
---	--	--	--	--	--	--	--	--------------	--------------	--	--

DILARANG MENGGANDAKAN, MENYALIN, MEMINDAHTANGKAN GAMBAR INI TANPA IZIN TERTULIS DARI POLITEKNIK NEGERI CILACAP

4

3

2

1

PENGGANTI DARI:

DIGANTI DENGAN

LAMPIRAN 11

Spiral Casing

DILARANG MENGGANDAKAN, MENYALIN, MEMINDAHKAN GAMBAR INI TANPA IZIN TERTULIS DARI POLITEKNIK NEGERI CILACAP

4		3		2		1	
No.	Perubahan	Tanggal	Nama	No.	Perubahan	Tanggal	Nama
△				△			

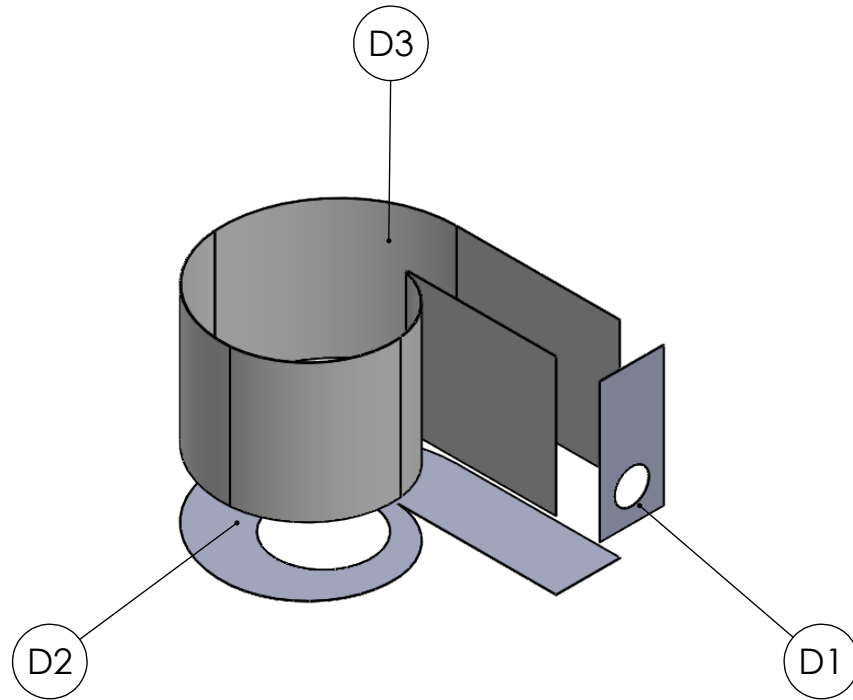

1	Wall Cover Spiral Casing	D3	Stainless 430	Lihat Detail	Dibeli	
1	Lower Spiral Casing	D2	Stainless 430	Lihat Detail	Dibeli	
1	Inlet Water	D1	Stainless 430	Lihat Detail	Dibeli	
B	Jml	Nama Bagian	No.Id	Bahan	Ukuran	Keterangan
	>	0 6 30 120 400 1000	Ukuran Lanjut:		No. Order:	Proyeksi:
	<	6 30 120 400 1000 2000				
	Tol	±0.1 ±0.2 ±0.3 ±0.5 ±0.8 ±1.2				

Nama:			Skala 1:5	Digambar	1-8-22	Rendi
SUB ASSEMBLY SPIRAL CASING				Diperiksa		Radhi
				Disahkan		Bayu
No. Assy:			Format	Satuan		
 Politeknik Negeri Cilacap, Jurusan Teknik Mesin Jl. Dr. Soetomo, No. 01, Sidakaya, Cilacap, 53212 Telp: 0282-533329, E-mail: tmpnc@politeknikcilacap.ac.id			A4	mm		

4		3			2		1
No.	Perubahan	Tanggal	Nama	No.	Perubahan	Tanggal	Nama
△				△			

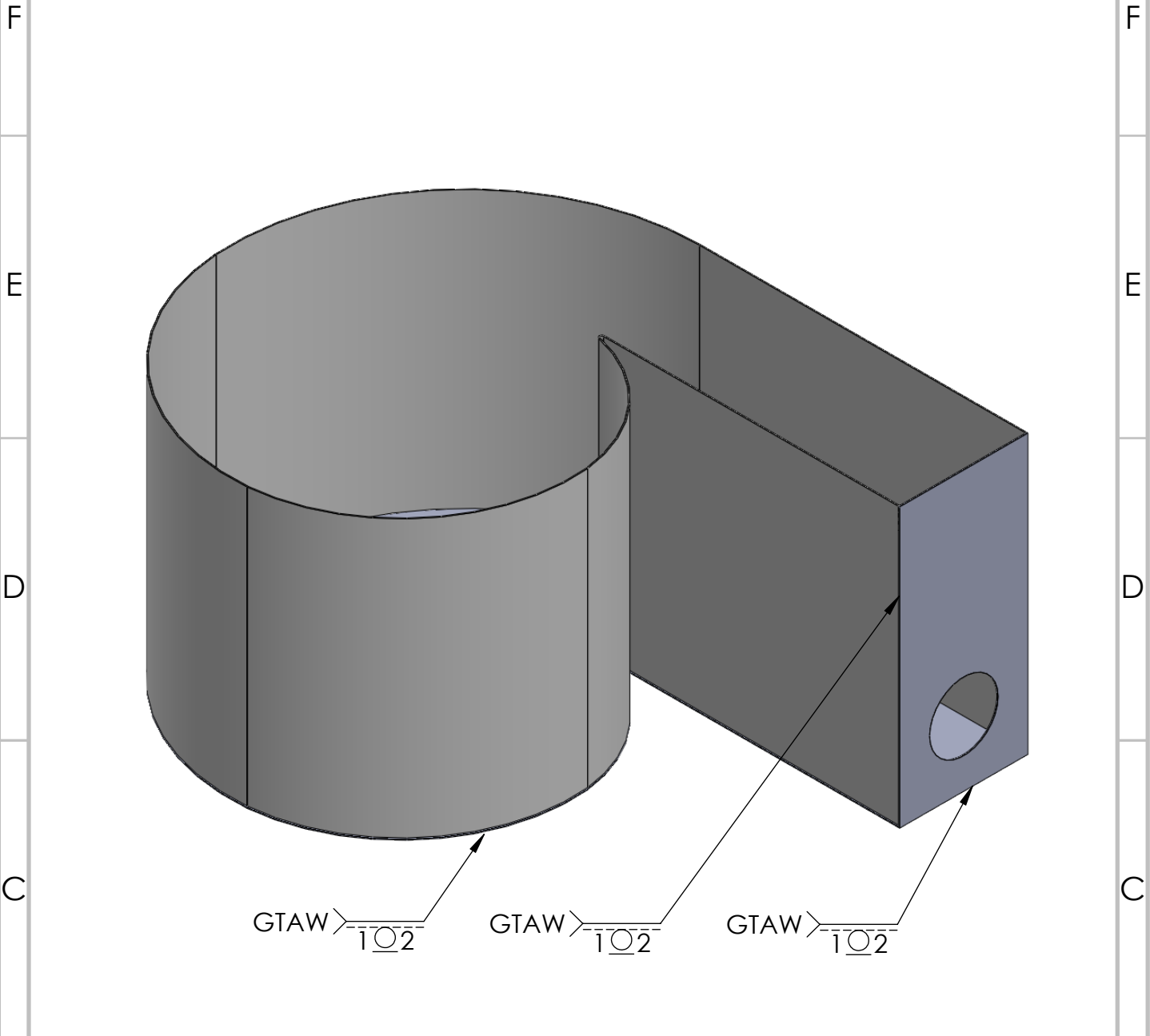

1	Wall Cover Spiral Casing	D3	Stainless 430	Lihat Detail	Dibeli
1	Lower Spiral Casing	D2	Stainless 430	Lihat Detail	Dibeli
1	Inlet Water	D1	Stainless 430	Lihat Detail	Dibeli
B	Jml Nama Bagian	No.Id	Bahan	Ukuran	Keterangan
>	0 6 30 120 400 1000	Ukuran Lanjut:		No. Order:	Proyeksi:
<	6 30 120 400 1000 2000				
Tol	±0.1 ±0.2 ±0.3 ±0.5 ±0.8 ±1.2				

A	Nama:	SUB ASSEMBLY SPIRAL CASING	Skala 1:5	Digambar	1-8-22	Rendi
	No. Assy:			Diperiksa		Radhi
				Disahkan		Bayu

A		Politeknik Negeri Cilacap, Jurusan Teknik Mesin Jl. Dr. Soetomo, No. 01, Sidakaya, Cilacap, 53212 Telp: 0282-533329, E-mail: tmpnc@politeknikcilacap.ac.id	Format	Satuan mm		
			A4			

4

3

2

1

No.	Perubahan	Tanggal	Nama	No.	Perubahan	Tanggal	Nama
△				△			

F

F

E

E

D

D

C

C

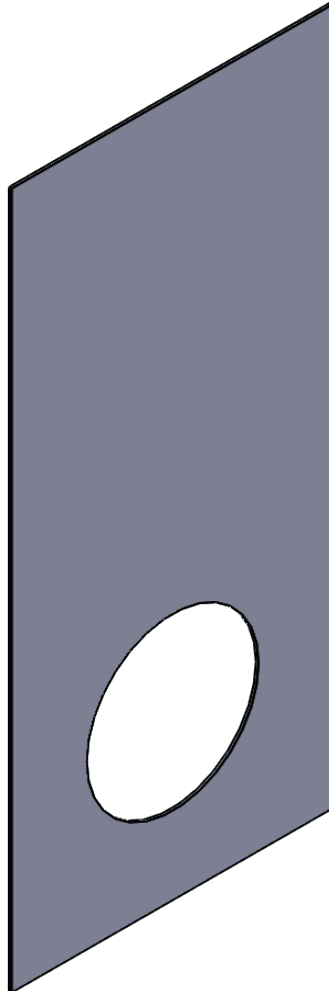

1	Inlet Water						D1	Stainless 430	Lihat Detail	Dibuat
B	Jml Nama Bagian						No.Id	Bahan	Ukuran	Keterangan
	>	0	6	30	120	400	1000	Ukuran Lanjut:	No. Order:	Proyeksi:
	<	6	30	120	400	1000	2000			
	Tol	±0.1	±0.2	±0.3	±0.5	±0.8	±1.2			

A	Nama:							Skala 1:1	Digambar	1-8-22	Rendi
	INLET WATER								Diperiksa		Radhi
									Disahkan		Bayu
No. Assy:											

 Politeknik Negeri Cilacap, Jurusan Teknik Mesin Jl. Dr. Soetomo, No. 01, Sidakaya, Cilacap, 53212 Telp: 0282-533329, E-mail: tmpnc@politeknikcilacap.ac.id							Format A4	Satuan mm		
---	--	--	--	--	--	--	----------------------------	----------------------------	--	--

4

3

2

1

PENGANTI DARI:

DIGANTI DENGAN

DILARANG MENGGANDAKAN, MENYALIN, MEMINDAHTANGANKAN GAMBAR INI
TANPA IZIN TERTULIS DARI POLITEKNIK NEGERI CILACAP

4			3			2			1
No.	Perubahan	Tanggal	Nama	No.	Perubahan	Tanggal	Nama		
△				△					

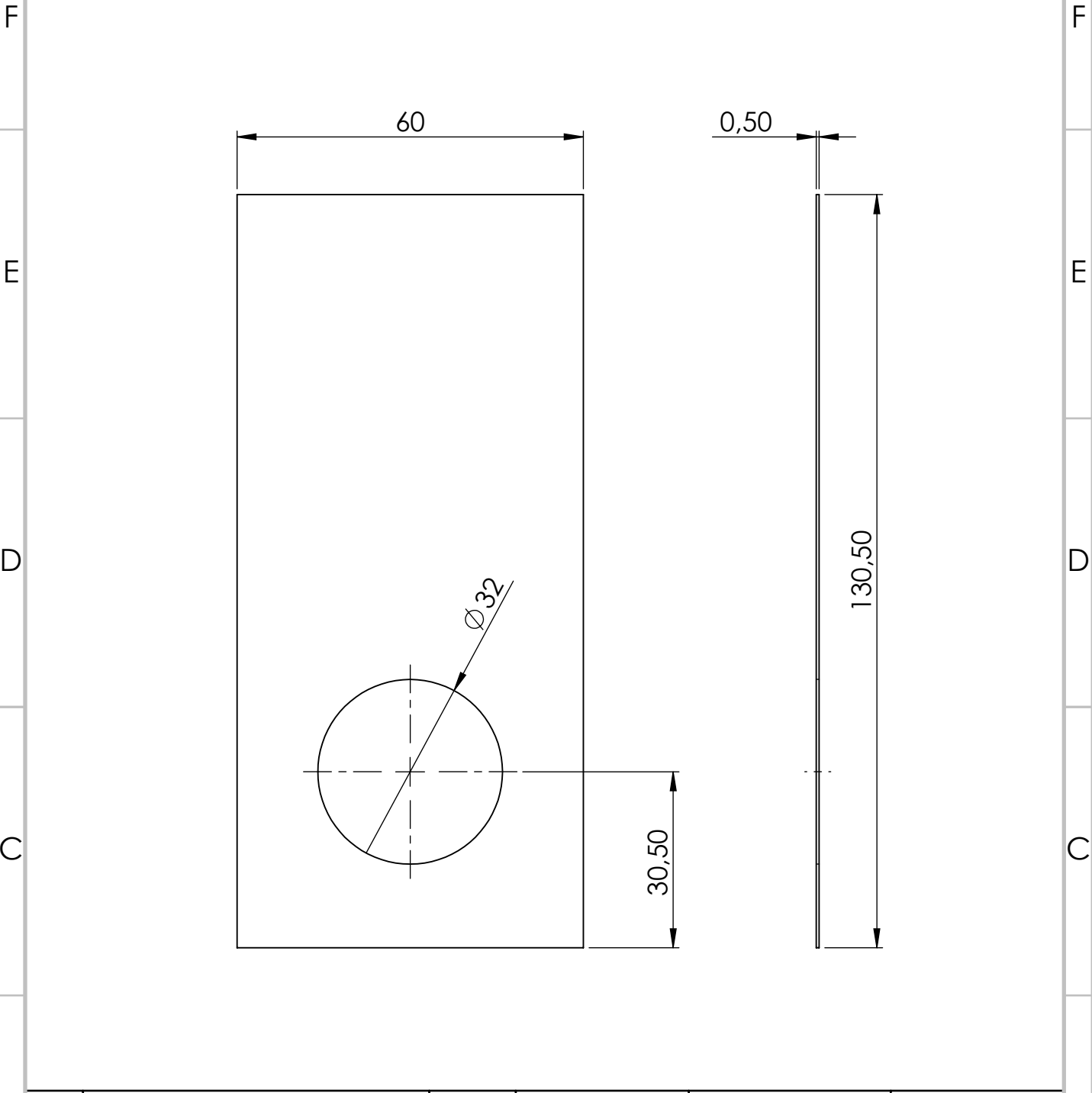

1		Inlet Water					D1	Stainless 430	Lihat Detail	Dibuat		
B	Jml	Nama Bagian					No.Id	Bahan	Ukuran	Keterangan		
	>	0	6	30	120	400	1000	Ukuran Lanjut:	No. Order:	Proyeksi:		
	<	6	30	120	400	1000	2000					
	Tol	±0.1	±0.2	±0.3	±0.5	±0.8	±1.2					
Nama:									Skala 1:1	Digambar	1-8-22	Rendi
INLET WATER										Diperiksa		Radhi
										Disahkan		Bayu
A	No. Assy:									Format A4	Satuan mm	

DILARANG MENGGANDAKAN, MENYALIN, MEMINDAHKAN GAMBAR INI TANPA IZIN TERTULIS DARI POLITEKNIK NEGERI CILACAP

4		3			2		1
No.	Perubahan	Tanggal	Nama	No.	Perubahan	Tanggal	Nama
△				△			

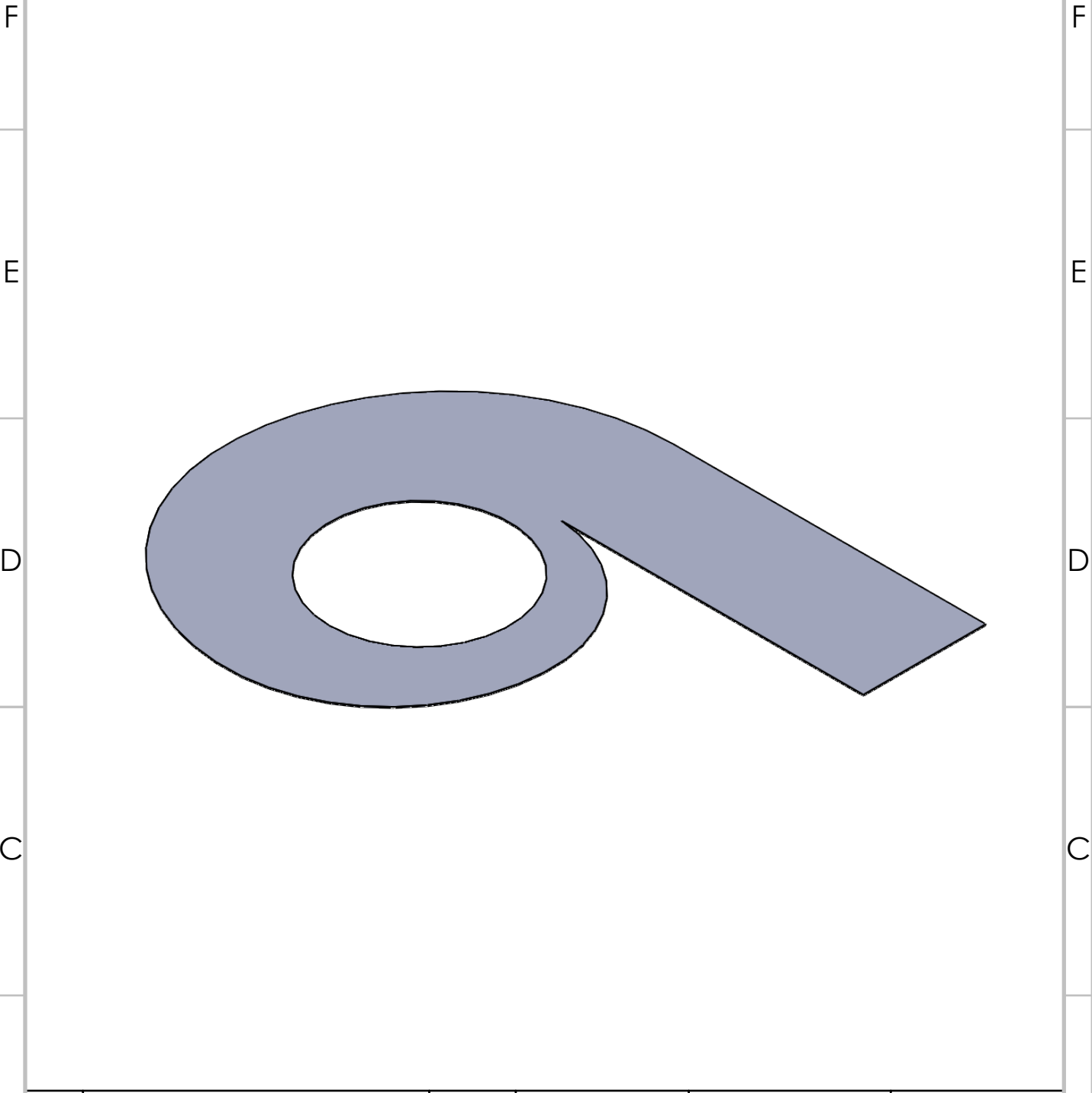

1		Lower Spiral Casing					D2	Stainless 430	Lihat Detail		Dibuat	
B		Jml Nama Bagian					No.Id	Bahan	Ukuran		Keterangan	
>	0	6	30	120	400	1000	Ukuran Lanjut:	No. Order:	Proyeksi:			
<	6	30	120	400	1000	2000						
Tol	±0.1	±0.2	±0.3	±0.5	±0.8	±1.2						
Nama:								Skala 1:2	Digambar	1-8-22	Rendi	
LOWER SPIRAL CASING									Diperiksa		Radhi	
									Disahkan		Bayu	
No. Assy:								Format A4	Satuan mm			
 Politeknik Negeri Cilacap, Jurusan Teknik Mesin Jl. Dr. Soetomo, No. 01, Sidakaya, Cilacap, 53212 Telp: 0282-533329, E-mail: tmpnc@politeknikcilacap.ac.id												

DILARANG MENGGANDAKAN, MENYALIN, MEMINDAHTANGKAN GAMBAR INI
TANPA IZIN TERTULIS DARI POLITEKNIK NEGERI CILACAP

4	3	2	1
No.	Perubahan	Tanggal	Nama
No.	Perubahan	Tanggal	Nama

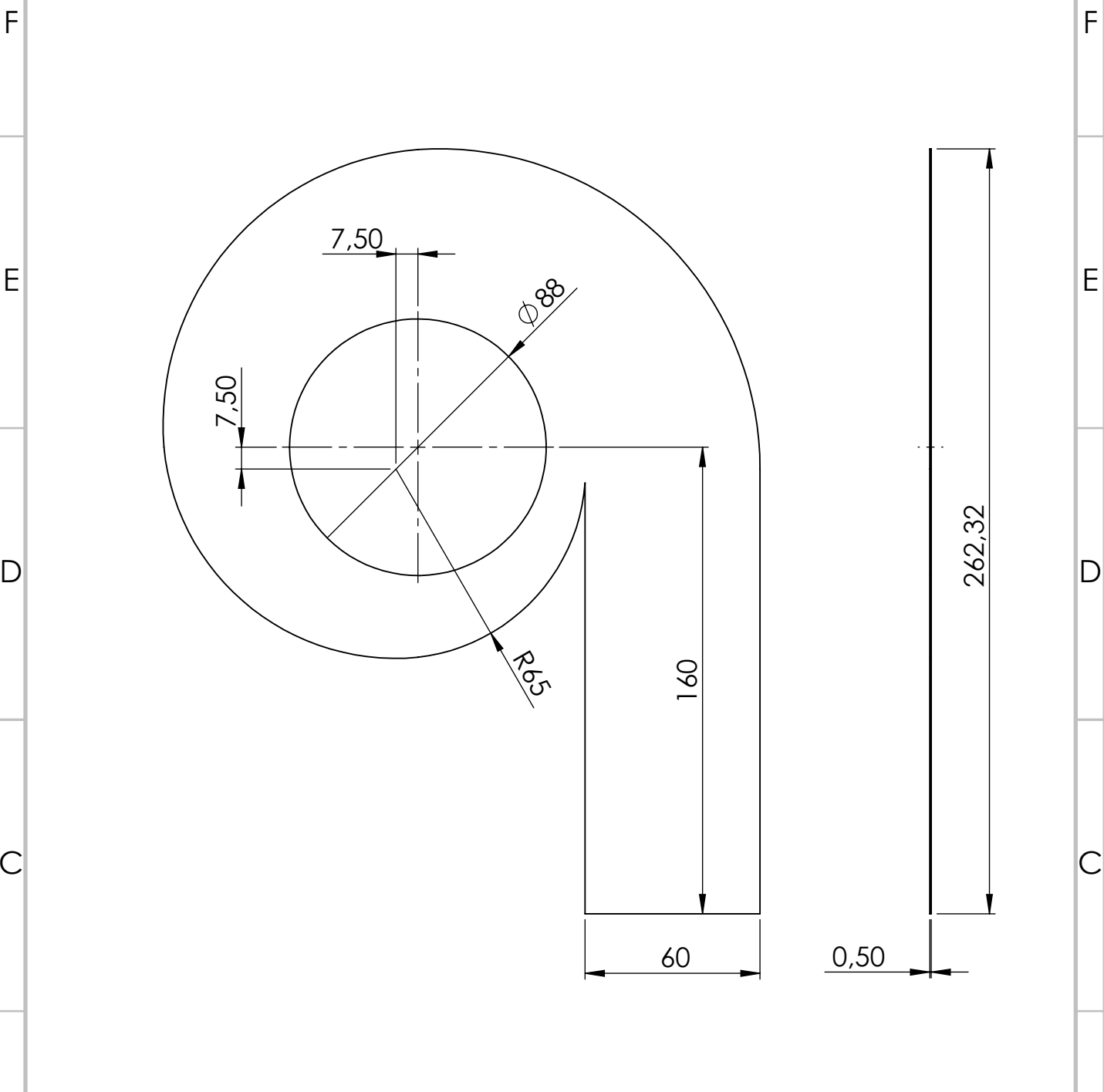

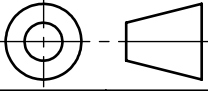
1	Lower Spiral Casing	D2	Stainless 430	Lihat Detail	Dibuat
B	Jml Nama Bagian	No.Id	Bahan	Ukuran	Keterangan
>	0 6 30 120 400 1000	Ukuran Lanjut:		No. Order:	Proyeksi: 
<	6 30 120 400 1000 2000				
Tol	±0.1 ±0.2 ±0.3 ±0.5 ±0.8 ±1.2				

Nama:	Skala 1:2	Digambar	1-8-22	Rendi
LOWER SPIRAL CASING		Diperiksa		Radhi
		Disahkan		Bayu
No. Assy:				

 Politeknik Negeri Cilacap, Jurusan Teknik Mesin Jl. Dr. Soetomo, No. 01, Sidakaya, Cilacap, 53212 Telp: 0282-533329, E-mail: tmpnc@politeknikcilacap.ac.id	Format A4	Satuan mm	
---	---------------------	---------------------	--

DILARANG MENGGANDAKAN, MENYALIN, MEMINDAHTANGKAN GAMBAR INI
TANPA IZIN TERTULIS DARI POLITEKNIK NEGERI CILACAP

4				3			2		1		
No.	Perubahan		Tanggal	Nama		No.	Perubahan		Tanggal	Nama	
△						△					

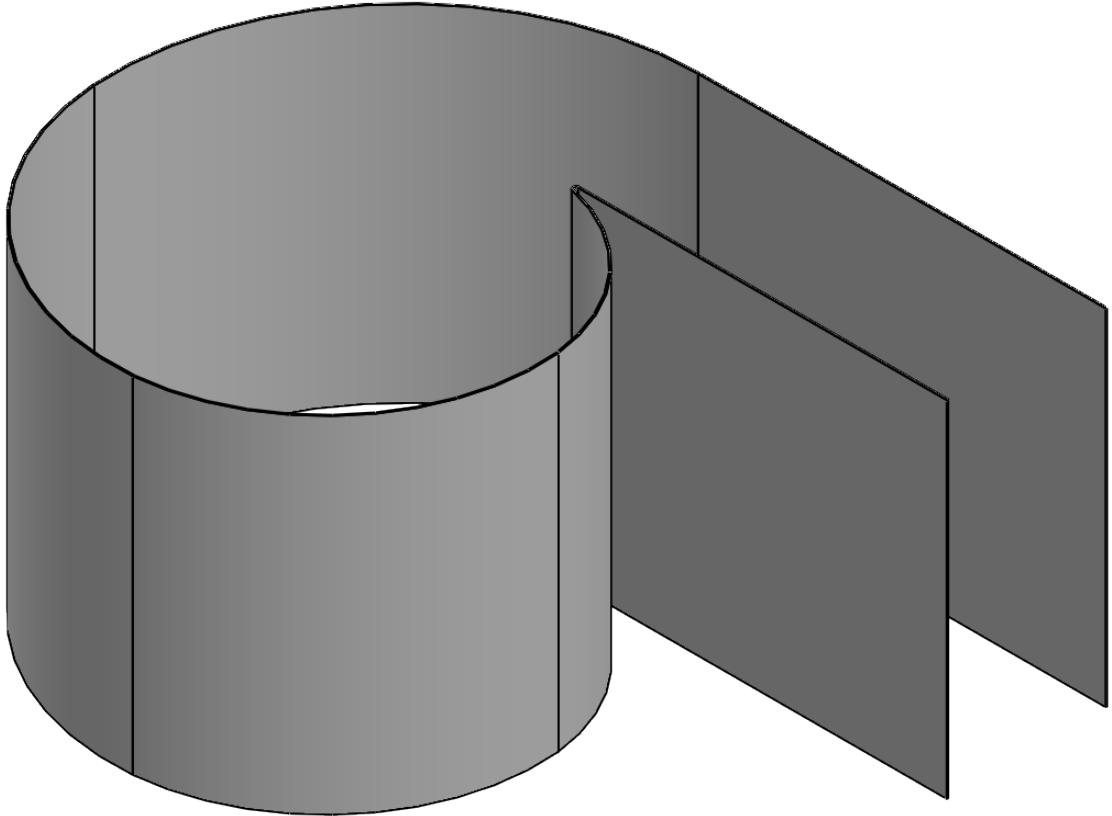

1		Wall Cover Spiral Casing					D3	Stainless 430	Lihat Detail		Dibuat			
B		Jml Nama Bagian					No.Id	Bahan	Ukuran		Keterangan			
		>	0	6	30	120	400	1000	Ukuran Lanjut:		No. Order:		Proyeksi:	
		<	6	30	120	400	1000	2000						
		Tol	±0.1	±0.2	±0.3	±0.5	±0.8	±1.2						

Nama:

WALL COVER SPIRAL CASING

No. Assy:

Skala

1:2

Digambar

Diperiksa

Disahkan

1-8-22

Rendi

Radhi

Bayu



Politeknik Negeri Cilacap, Jurusan Teknik Mesin

Jl. Dr. Soetomo, No. 01, Sidakaya, Cilacap, 53212

Telp: 0282-533329, E-mail: tmpnc@politeknikcilacap.ac.id

Format



A4

Satuan

mm

4				3			2		1
PENGANTI DARI: DIGANTI DENGAN									

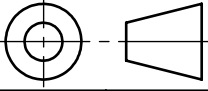
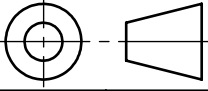
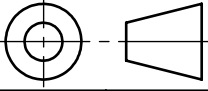
DILARANG MENGGANDAKAN, MENYALIN, MEMINDAHKANKAN GAMBAR INI
TANPA IZIN TERTULIS DARI POLITEKNIK NEGERI CILACAP

4	3		2		1																																														
No.	Perubahan	Tanggal	Nama	No.	Perubahan	Tanggal	Nama																																												
△				△																																															
F	<div style="display: flex; justify-content: space-around; align-items: center;"> <div style="text-align: center;"> <p>129,50</p> </div> <div style="text-align: center;"> <p>0,50</p> </div> </div>						F																																												
E							E																																												
D	824,50						D																																												
C							C																																												
B	<table border="1" style="width: 100%; border-collapse: collapse;"> <thead> <tr> <th>1</th> <th colspan="5">Wall Cover Spiral Casing</th> <th>D3</th> <th>Stainless 430</th> <th>Lihat Detail</th> <th>Dibuat</th> </tr> <tr> <th>Jml</th> <th colspan="5">Nama Bagian</th> <th>No.Id</th> <th>Bahan</th> <th>Ukuran</th> <th>Keterangan</th> </tr> </thead> <tbody> <tr> <td>></td> <td>0</td> <td>6</td> <td>30</td> <td>120</td> <td>400</td> <td>1000</td> <td rowspan="3">Ukuran Lanjut:</td> <td rowspan="3">No. Order:</td> <td rowspan="3">Proyeksi: </td> </tr> <tr> <td><</td> <td>6</td> <td>30</td> <td>120</td> <td>400</td> <td>1000</td> <td>2000</td> </tr> <tr> <td>Tol</td> <td>±0.1</td> <td>±0.2</td> <td>±0.3</td> <td>±0.5</td> <td>±0.8</td> <td>±1.2</td> </tr> </tbody> </table>		1	Wall Cover Spiral Casing					D3	Stainless 430	Lihat Detail	Dibuat	Jml	Nama Bagian					No.Id	Bahan	Ukuran	Keterangan	>	0	6	30	120	400	1000	Ukuran Lanjut:	No. Order:	Proyeksi: 	<	6	30	120	400	1000	2000	Tol	±0.1	±0.2	±0.3	±0.5	±0.8	±1.2					B
1	Wall Cover Spiral Casing					D3	Stainless 430	Lihat Detail	Dibuat																																										
Jml	Nama Bagian					No.Id	Bahan	Ukuran	Keterangan																																										
>	0	6	30	120	400	1000	Ukuran Lanjut:	No. Order:	Proyeksi: 																																										
<	6	30	120	400	1000	2000																																													
Tol	±0.1	±0.2	±0.3	±0.5	±0.8	±1.2																																													
A	<p>Nama:</p> <h2 style="text-align: center;">WALL COVER SPIRAL CASING</h2> <p>No. Assy:</p>						<p>Skala: 1:5</p> <p>Digambar: 1-8-22 Rendi</p> <p>Diperiksa: Radhi</p> <p>Disahkan: Bayu</p>		A																																										
 <p>Politeknik Negeri Cilacap, Jurusan Teknik Mesin Jl. Dr. Soetomo, No. 01, Sidakaya, Cilacap, 53212 Telp: 0282-533329, E-mail: tmpnc@politeknikcilacap.ac.id</p>						Format: A4	Satuan: mm																																												
4	3		2		1																																														

LAMPIRAN 12

Penstock

DILARANG MENGGANDAKAN, MENYALIN, MEMINDAHTANGANKAN GAMBAR INI
TANPA IZIN TERTULIS DARI POLITEKNIK NEGERI CILACAP

4		3		2		1	
No.	Perubahan	Tanggal	Nama	No.	Perubahan	Tanggal	Nama
△				△			

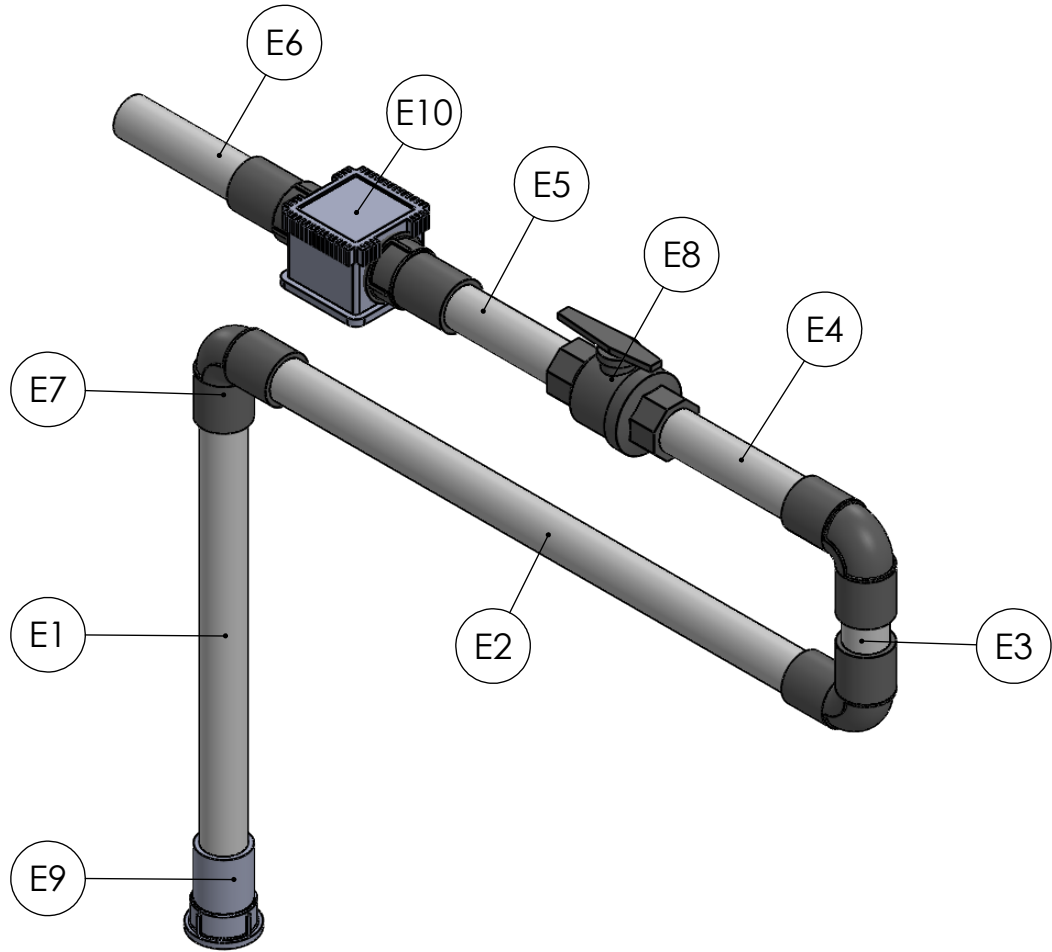

1	Flow Meter Digital	E10	-	Lihat Detail	Dibeli
1	Faucet Socket	E9	PVC	Lihat Detail	Dibeli
1	Ball Valve	E8	PVC	Lihat Detail	Dibeli
1	Elbow 90°	E7	PVC	Lihat Detail	Dibeli
1	Pipa 6	E6	PVC	Lihat Detail	Dibeli
1	Pipa 5	E5	PVC	Lihat Detail	Dibeli
1	Pipa 4	E4	PVC	Lihat Detail	Dibeli
1	Pipa 3	E3	PVC	Lihat Detail	Dibeli
1	Pipa 2	E2	PVC	Lihat Detail	Dibeli
1	Pipa 1	E1	PVC	Lihat Detail	Dibeli



B	Jml	Nama Bagian					No.Id	Bahan	Ukuran	Keterangan	B
	>	0	6	30	120	400	1000	Ukuran Lanjut:	No. Order:	Proyeksi:	
	<	6	30	120	400	1000	2000				
	Tol	±0.1	±0.2	±0.3	±0.5	±0.8	±1.2				

Nama:				Skala 1:5	Digambar	1-8-22	Rendi
SUB ASSEMBLY PENSTOCK					Diperiksa		Radhi
					Disahkan		Bayu
No. Assy:							

 Politeknik Negeri Cilacap, Jurusan Teknik Mesin Jl. Dr. Soetomo, No. 01, Sidakaya, Cilacap, 53212 Telp: 0282-533329, E-mail: tmpnc@politeknikcilacap.ac.id				Format A4	Satuan mm		
---	--	--	--	---------------------	---------------------	--	--

4		3		2		1	
PENGANTI DARI:				DIGANTI DENGAN			

DILARANG MENGGANDAKAN, MENYALIN, MEMINDAHTANGKAN GAMBAR INI TANPA IZIN TERTULIS DARI POLITEKNIK NEGERI CILACAP

	4	3	2	1									
	No.	Perubahan	Tanggal	Nama		No.	Perubahan	Tanggal	Nama				
	△					△							
F											F		
E											E		
D											D		
C											C		
B											B		
A											A		
	1	Pipa 1					E1	PVC		Lihat Detail		Dibeli	
	Jml	Nama Bagian					No.Id	Bahan		Ukuran		Keterangan	
	>	0	6	30	120	400	Ukuran Lanjut:		No. Order:		Proyeksi:		
	<	6	30	120	400	1000							
	Tol	±0.1	±0.2	±0.3	±0.5	±0.8	±1.2						
	Nama:						Skala		Digambar	1-8-22	Rendi		
	PIPA 1						1:2		Diperiksa		Radhi		
	No. Assy:								Disahkan		Bayu		
	 Politeknik Negeri Cilacap, Jurusan Teknik Mesin Jl. Dr. Soetomo, No. 01, Sidakaya, Cilacap, 53212 Telp: 0282-533329, E-mail: tmpnc@politeknikcilacap.ac.id						Format		Satuan				
							A4		mm				
	4	3	2	1									
PENGANTI DARI:			DIGANTI DENGAN										

	4	3	2	
No.	Perubahan	Tanggal	Nama	No.
No.	Perubahan	Tanggal	Nama	No.

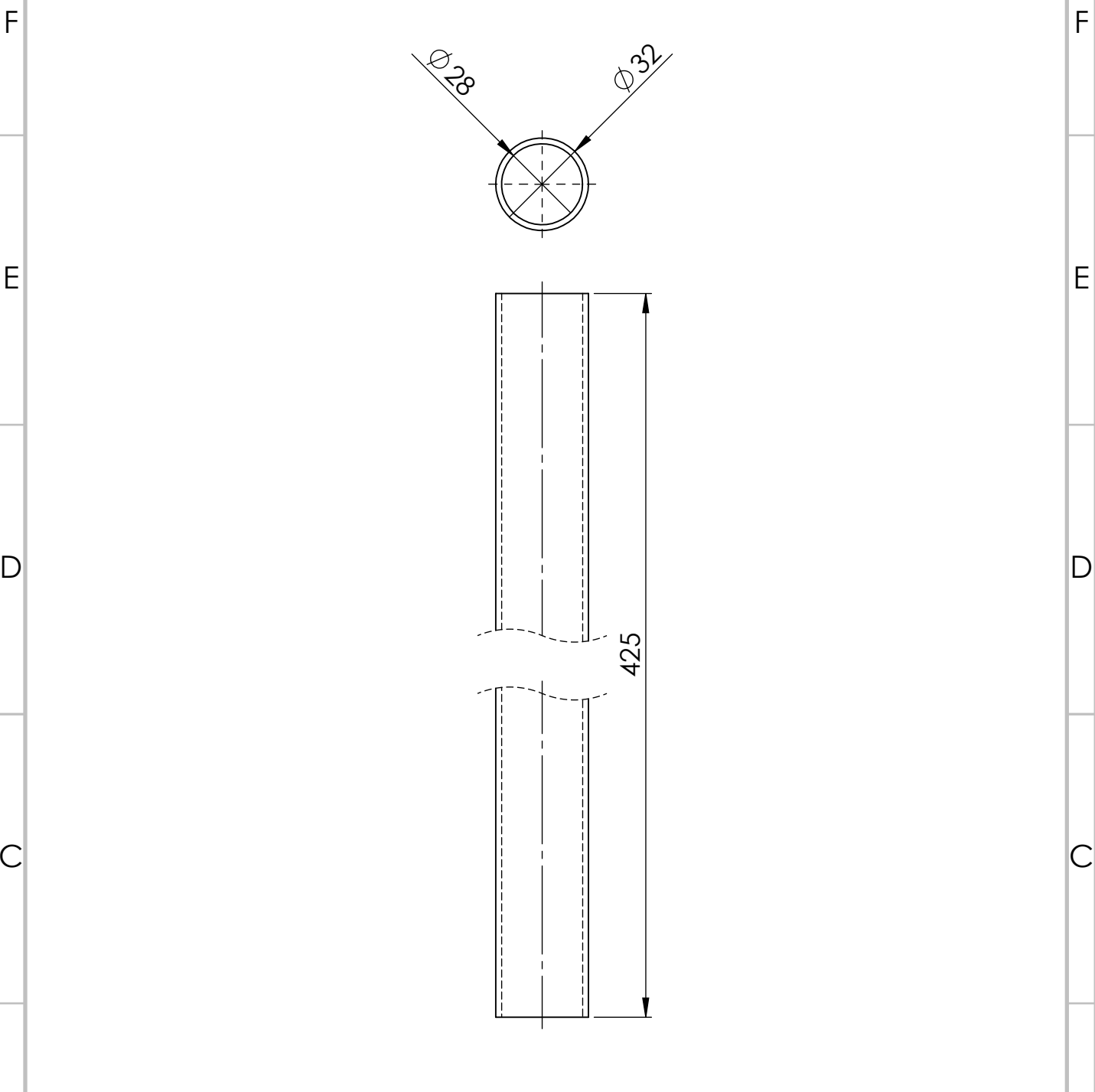



1	Pipa 1						E1	PVC	Lihat Detail	Dibeli
B	Jml Nama Bagian						No.Id	Bahan	Ukuran	Keterangan
	>	0	6	30	120	400	1000	Ukuran Lanjut:	No. Order:	Proyeksi:
	<	6	30	120	400	1000	2000			
	Tol	±0.1	±0.2	±0.3	±0.5	±0.8	±1.2			

Nama:	Skala	Digambar	1-8-22	Rendi
<h1>PIPA 1</h1>	1:2	Diperiksa		Radhi
		Disahkan		Bayu

Politeknik Negeri Cilacap, Jurusan Teknik Mesin Jl. Dr. Soetomo, No. 01, Sidakaya, Cilacap, 53212 Telp: 0282-533329, E-mail: tmpnc@politeknikcilacap.ac.id	Format	Satuan	mm	
	A4			

DILARANG MENGGANDAKAN, MENYALIN, MEMINDAHKAN GAMBAR INI
TANPA IZIN TERTULIS DARI POLITEKNIK NEGERI CILACAP

	4	3	2	1																
No.	Perubahan	Tanggal	Nama	No.	Perubahan	Tanggal	Nama													
△				△																
F							F													
E							E													
D							D													
C							C													
B	1 Pipa 2		E2 PVC		Lihat Detail		Dibeli													
B	Jml Nama Bagian		No.Id Bahan		Ukuran		Keterangan													
	>	0 6 30 120 400 1000	Ukuran Lanjut:		No. Order:		Proyeksi:													
	<	6 30 120 400 1000 2000																		
	Tol	±0.1 ±0.2 ±0.3 ±0.5 ±0.8 ±1.2																		
A	Nama: PIPA 2 No. Assy:				Skala 1:5		<table border="1" style="width: 100%; border-collapse: collapse;"> <tr> <td style="width: 50%;">Digambar</td> <td style="width: 50%;">1-8-22</td> <td style="width: 50%;">Rendi</td> </tr> <tr> <td>Diperiksa</td> <td></td> <td>Radhi</td> </tr> <tr> <td>Disahkan</td> <td></td> <td>Bayu</td> </tr> <tr> <td></td> <td></td> <td></td> </tr> </table>		Digambar	1-8-22	Rendi	Diperiksa		Radhi	Disahkan		Bayu			
Digambar	1-8-22	Rendi																		
Diperiksa		Radhi																		
Disahkan		Bayu																		
	 Politeknik Negeri Cilacap, Jurusan Teknik Mesin Jl. Dr. Soetomo, No. 01, Sidakaya, Cilacap, 53212 Telp: 0282-533329, E-mail: tmpnc@politeknikcilacap.ac.id				Format A4		Satuan mm													
	4	3	2	1																
	PENGANTI DARI:		DIGANTI DENGAN																	

DILARANG MENGGANDAKAN, MENYALIN, MEMINDAHTANGKAN GAMBAR INI
TANPA IZIN TERTULIS DARI POLITEKNIK NEGERI CILACAP

4	3	2	1
No.	Perubahan	Tanggal	Nama
No.	Perubahan	Tanggal	Nama

F
E
D
C
B
A

F
E
D
C
B
A

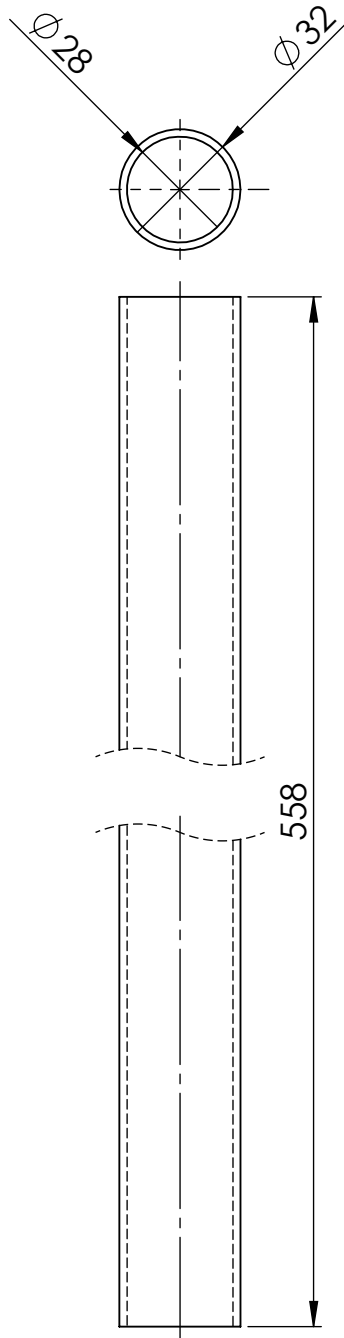

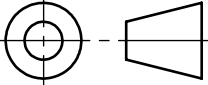

1	Pipa 2	E2	PVC	Lihat Detail	Dibeli
Jml	Nama Bagian	No.Id	Bahan	Ukuran	Keterangan
>	0 6 30 120 400 1000	Ukuran Lanjut:		No. Order:	Proyeksi: 
<	6 30 120 400 1000 2000				
Tol	±0.1 ±0.2 ±0.3 ±0.5 ±0.8 ±1.2				

Nama:	1:2	Digambar	1-8-22	Rendi
PIPA 2		Diperiksa		Radhi
		Disahkan		Bayu
No. Assy:				

 Politeknik Negeri Cilacap, Jurusan Teknik Mesin Jl. Dr. Soetomo, No. 01, Sidakaya, Cilacap, 53212 Telp: 0282-533329, E-mail: tmpnc@politeknikcilacap.ac.id	Format A4	Satuan mm	
---	---------------------	---------------------	--

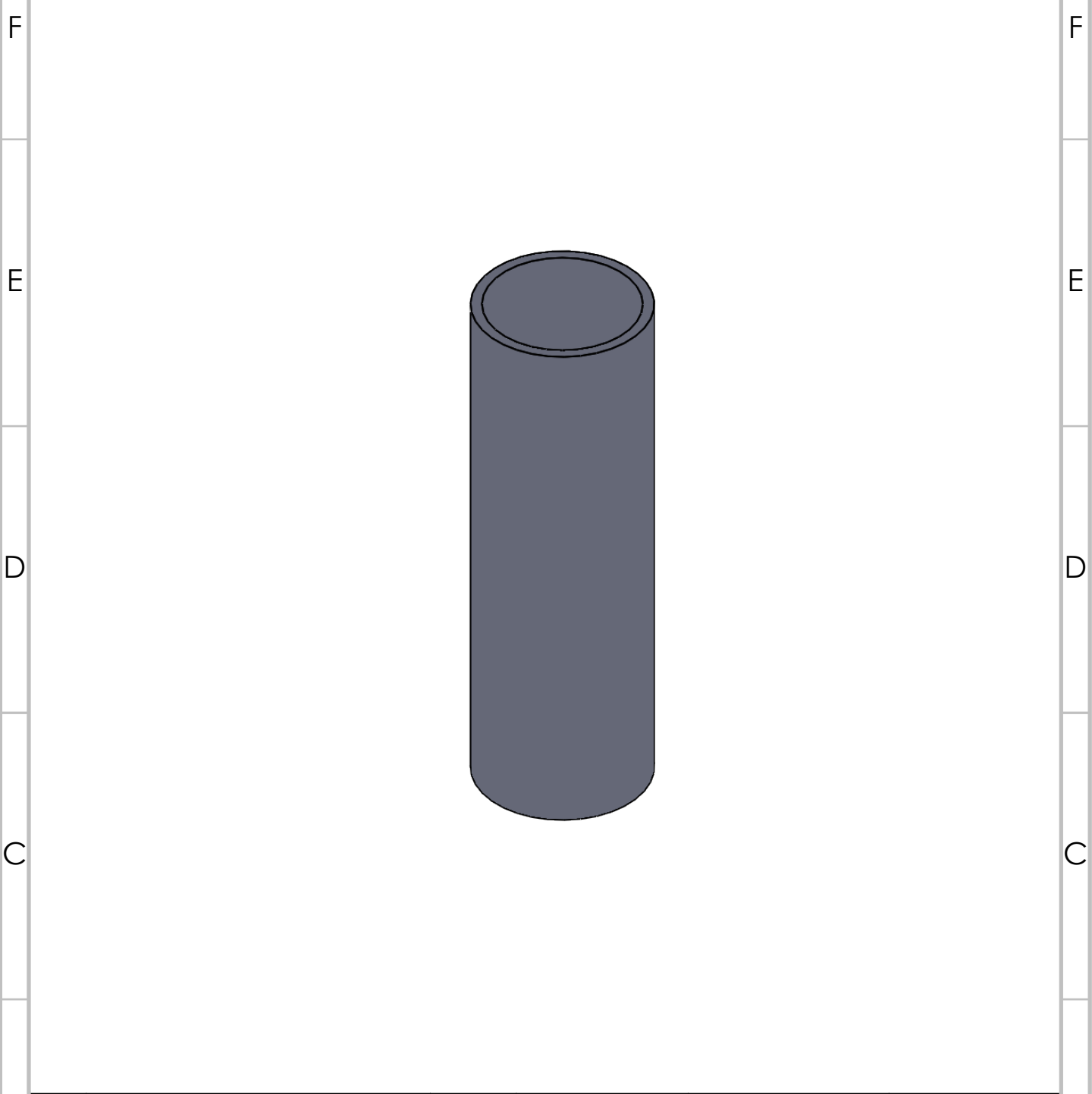
4		3			2		1
No.	Perubahan	Tanggal	Nama	No.	Perubahan	Tanggal	Nama
△				△			



1	Pipa 3					E3	PVC	Lihat Detail	Dibeli		
B	Jml	Nama Bagian					No.Id	Bahan	Ukuran	Keterangan	
	>	0	6	30	120	400	1000	Ukuran Lanjut:	No. Order:	Proyeksi:	
	<	6	30	120	400	1000	2000				
	Tol	±0.1	±0.2	±0.3	±0.5	±0.8	±1.2				
A	Nama: PIPA 3							Skala 1:1	Digambar	1-8-22	Rendi
	No. Assy:								Diperiksa		Radhi
	 Politeknik Negeri Cilacap, Jurusan Teknik Mesin Jl. Dr. Soetomo, No. 01, Sidakaya, Cilacap, 53212 Telp: 0282-533329, E-mail: tmpnc@politeknikcilacap.ac.id							Format A4			

DILARANG MENGGANDAKAN, MENYALIN, MEMINDAHKAN GAMBAR INI TANPA IZIN TERTULIS DARI POLITEKNIK NEGERI CILACAP

4				3		2		1		
No.	Perubahan			Tanggal	Nama	No.	Perubahan		Tanggal	Nama
△						△				

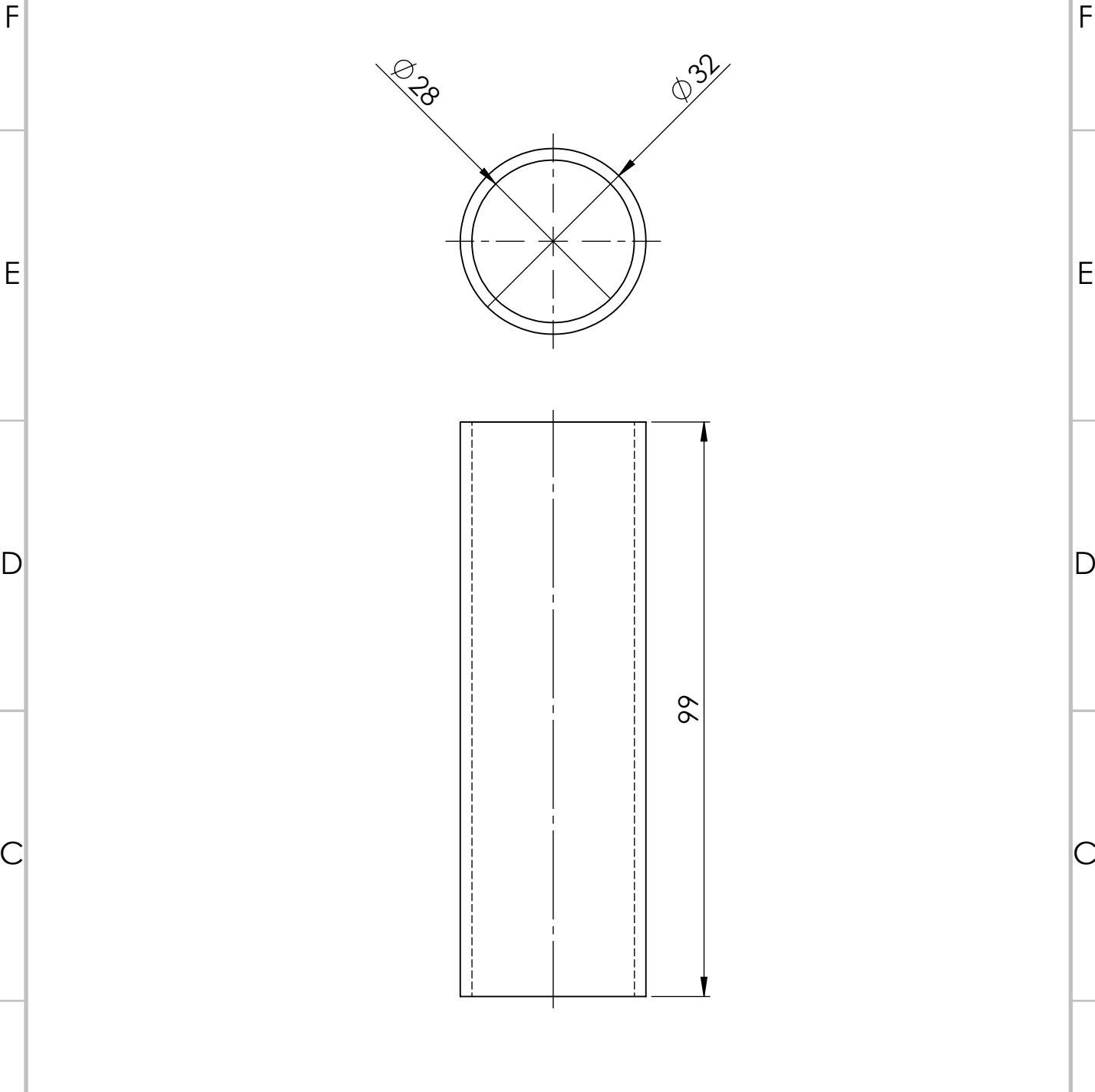

B	1	Pipa 3					E3	PVC	Lihat Detail	Dibeli		
	Jml	Nama Bagian					No.Id	Bahan	Ukuran	Keterangan		
	>	0	6	30	120	400	1000	Ukuran Lanjut:	No. Order:	Proyeksi:		
	<	6	30	120	400	1000	2000					
	Tol	±0.1	±0.2	±0.3	±0.5	±0.8	±1.2					
Nama:									Skala 1:1	Digambar	1-8-22	Rendi
PIPA 3										Diperiksa		Radhi
										Disahkan		Bayu
No. Assy:												
A									Format A4	Satuan mm		
	Politeknik Negeri Cilacap, Jurusan Teknik Mesin Jl. Dr. Soetomo, No. 01, Sidakaya, Cilacap, 53212 Telp: 0282-533329, E-mail: tmpnc@politeknikcilacap.ac.id											

4				3		2		1
---	--	--	--	---	--	---	--	---

DILARANG MENGGANDAKAN, MENYALIN, MEMINDAHKAN GAMBAR INI
TANPA IZIN TERTULIS DARI POLITEKNIK NEGERI CILACAP

	4	3			2		1
No.	Perubahan	Tanggal	Nama	No.	Perubahan	Tanggal	Nama
△				△			

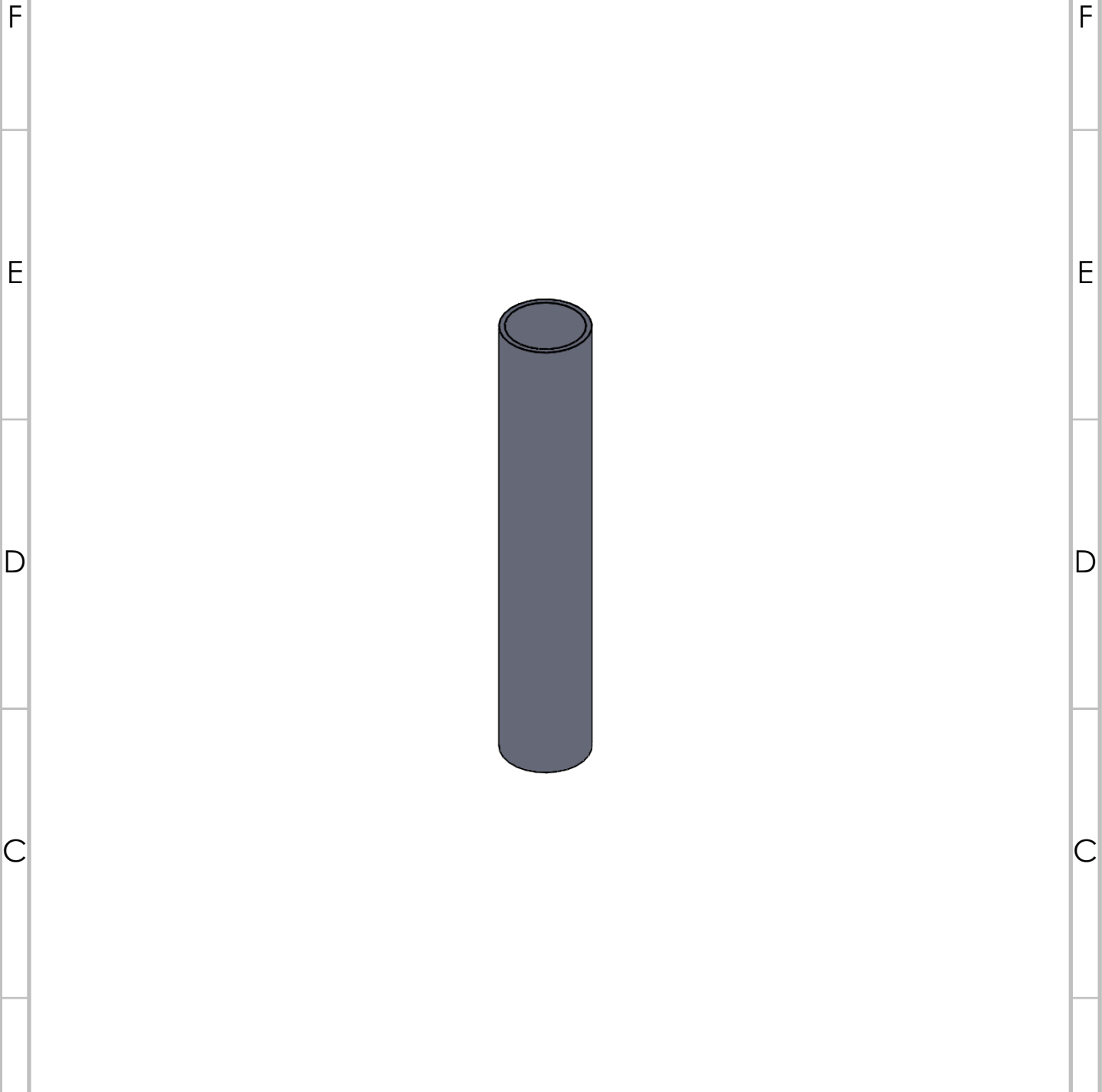

1	Pipa 4					E4	PVC	Lihat Detail	Dibeli		
B	Jml	Nama Bagian					No.Id	Bahan	Ukuran	Keterangan	
>	0	6	30	120	400	1000	Ukuran Lanjut:	No. Order:	Proyeksi:		
<	6	30	120	400	1000	2000					
Tol	±0.1	±0.2	±0.3	±0.5	±0.8	±1.2					
Nama: <div style="text-align: center; font-size: 24px; font-weight: bold; margin-top: 10px;">PIPA 4</div> No. Assy:								Skala 1:2	Digambar 1-8-22 Rendi	Diperiksa Radhi	
									Disahkan Bayu		
Politeknik Negeri Cilacap, Jurusan Teknik Mesin Jl. Dr. Soetomo, No. 01, Sidakaya, Cilacap, 53212 Telp: 0282-533329, E-mail: tmpnc@politeknikcilacap.ac.id								Format A4	Satuan mm		

4		3		2		1	
No.	Perubahan	Tanggal	Nama	No.	Perubahan	Tanggal	Nama
△				△			

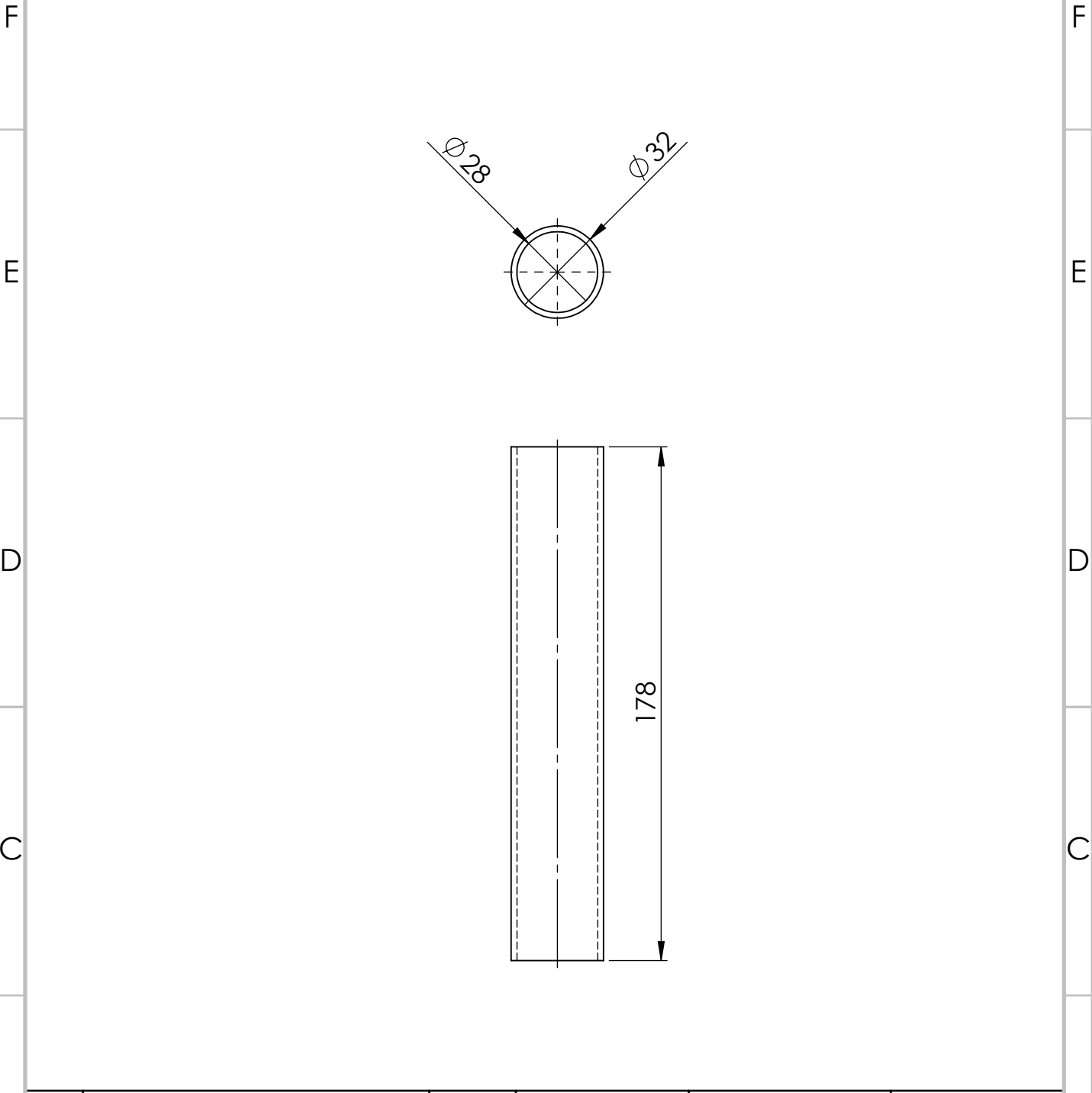

1	Pipa 4					E4	PVC	Lihat Detail	Dibeli		
Jml	Nama Bagian					No.Id	Bahan	Ukuran	Keterangan		
>	0	6	30	120	400	1000	Ukuran Lanjut:	No. Order:	Proyeksi: 		
<	6	30	120	400	1000	2000					
Tol	±0.1	±0.2	±0.3	±0.5	±0.8	±1.2					
Nama: <h3 style="text-align: center;">PIPA 4</h3>								Skala 1:2	Digambar	1-8-22	Rendi
No. Assy:									Diperiksa		Radhi
									Disahkan		Bayu
Politeknik Negeri Cilacap, Jurusan Teknik Mesin Jl. Dr. Soetomo, No. 01, Sidakaya, Cilacap, 53212 Telp: 0282-533329, E-mail: tmpnc@politeknikcilacap.ac.id								Format A4	Satuan mm		

DILARANG MENGGANDAKAN, MENYALIN, MEMINDAH TANGKANKAN GAMBAR INI
 TANPA IZIN TERTULIS DARI POLITEKNIK NEGERI CILACAP

4		3			2		1
No.	Perubahan	Tanggal	Nama	No.	Perubahan	Tanggal	Nama
△				△			

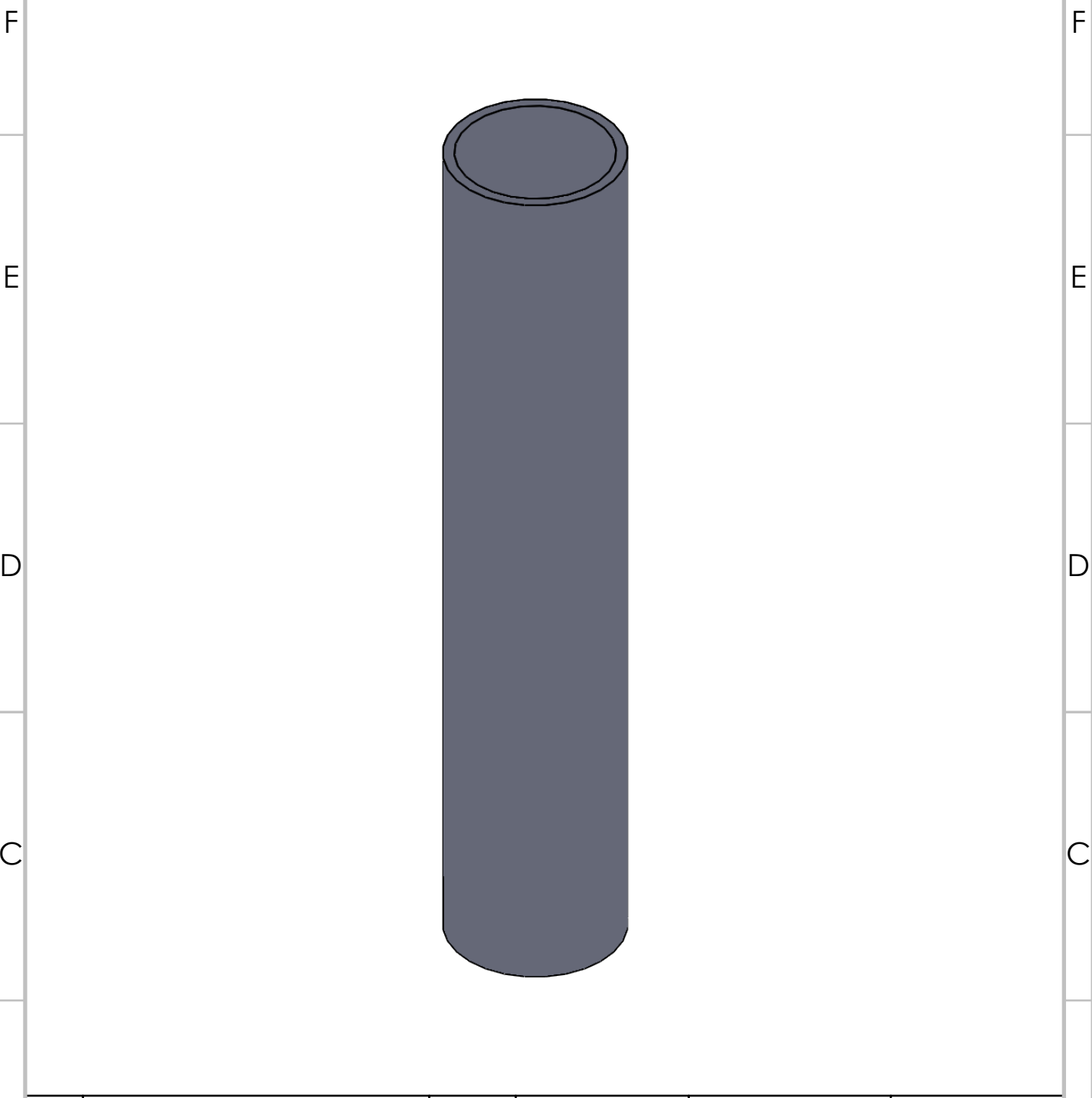
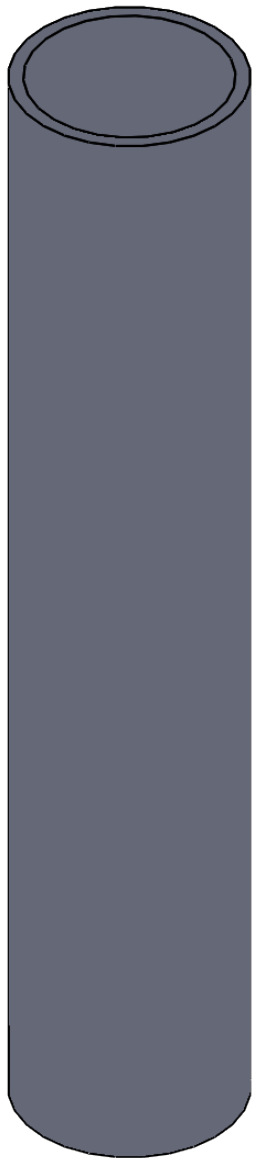

1	Pipa 5	E5	Stainless 430	Lihat Detail	Dibeli		
Jml	Nama Bagian	No.Id	Bahan	Ukuran	Keterangan		
>	0 6 30 120 400 1000	Ukuran Lanjut:		No. Order:	Proyeksi:		
<	6 30 120 400 1000 2000						
Tol	±0.1 ±0.2 ±0.3 ±0.5 ±0.8 ±1.2						
Nama:				Skala 1:1	Digambar	1-8-22	Rendi
PIPA 5					Diperiksa		Radhi
					Disahkan		Bayu
No. Assy:							
 Politeknik Negeri Cilacap, Jurusan Teknik Mesin Jl. Dr. Soetomo, No. 01, Sidakaya, Cilacap, 53212 Telp: 0282-533329, E-mail: tmpnc@politeknikcilacap.ac.id				Format A4	Satuan mm		

DILARANG MENGGANDAKAN, MENYALIN, MEMINDAHTANGKAN GAMBAR INI TANPA IZIN TERTULIS DARI POLITEKNIK NEGERI CILACAP

PENGGANTI DARI:

DIGANTI DENGAN

DILARANG MENGGANDAKAN, MENYALIN, MEMINDAHKAN GAMBAR INI TANPA IZIN TERTULIS DARI POLITEKNIK NEGERI CILACAP

	4	3	2	1
No.	Perubahan	Tanggal	Nama	No.
△				△
No.	Perubahan	Tanggal	Nama	

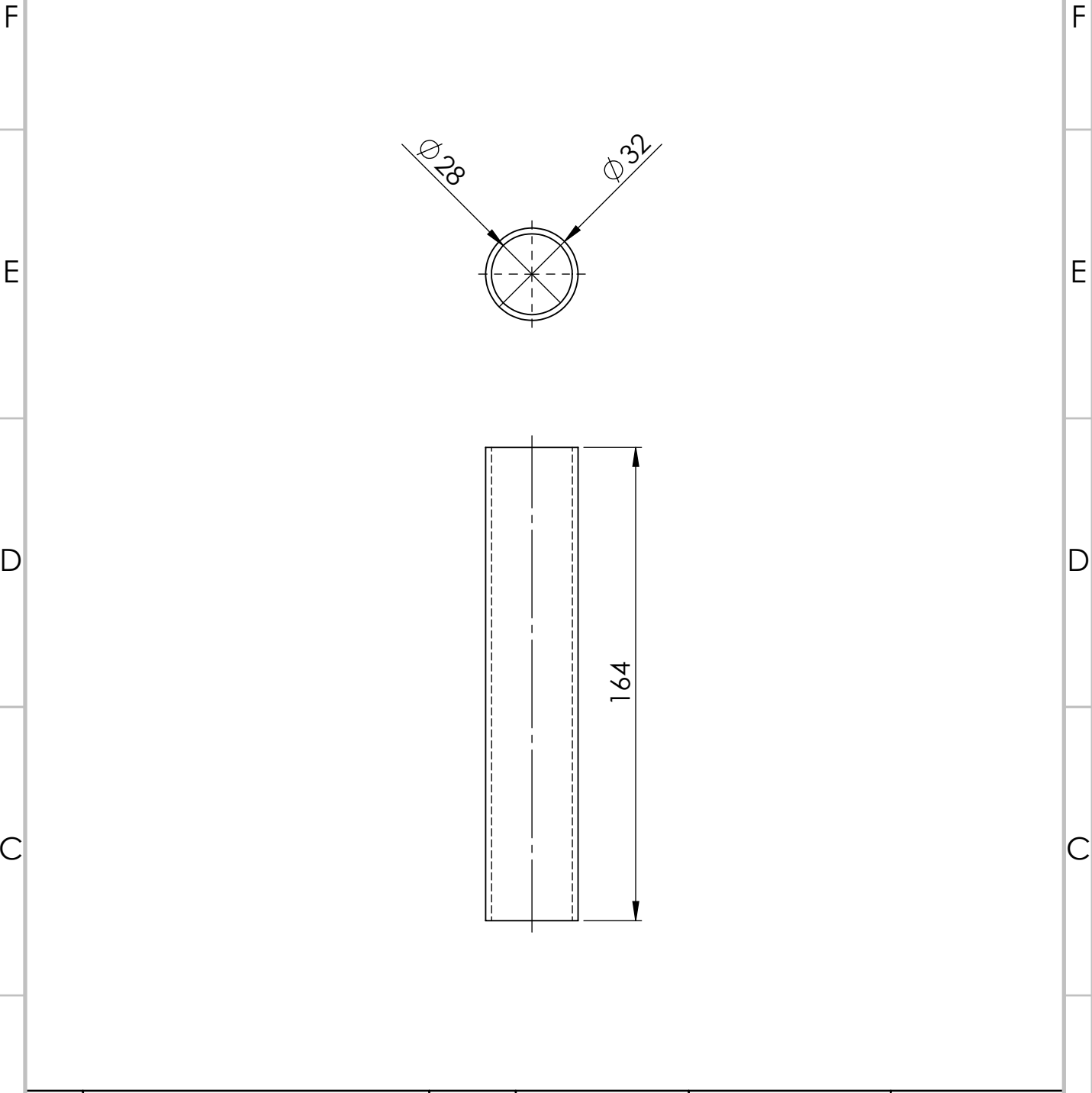

1	Pipa 5	E5	Stainless 430	Lihat Detail	Dibeli				
Jml	Nama Bagian	No.Id	Bahan	Ukuran	Keterangan				
>	0 6 30 120 400 1000	Ukuran Lanjut:		No. Order:	Proyeksi:				
<	6 30 120 400 1000 2000								
Tol	±0.1 ±0.2 ±0.3 ±0.5 ±0.8 ±1.2								
Nama:	PIPA 5					Skala	Digambar	1-8-22	Rendi
No. Assy:						1:2	Diperiksa		Radhi
			Disahkan		Bayu				
		Format	Satuan						
		A4	mm						

DILARANG MENGGANDAKAN, MENYALIN, MEMINDAHKAN GAMBAR INI
TANPA IZIN TERTULIS DARI POLITEKNIK NEGERI CILACAP

	4	3	2	1
No.	Perubahan	Tanggal	Nama	No.
△				△
No.	Perubahan	Tanggal	Nama	

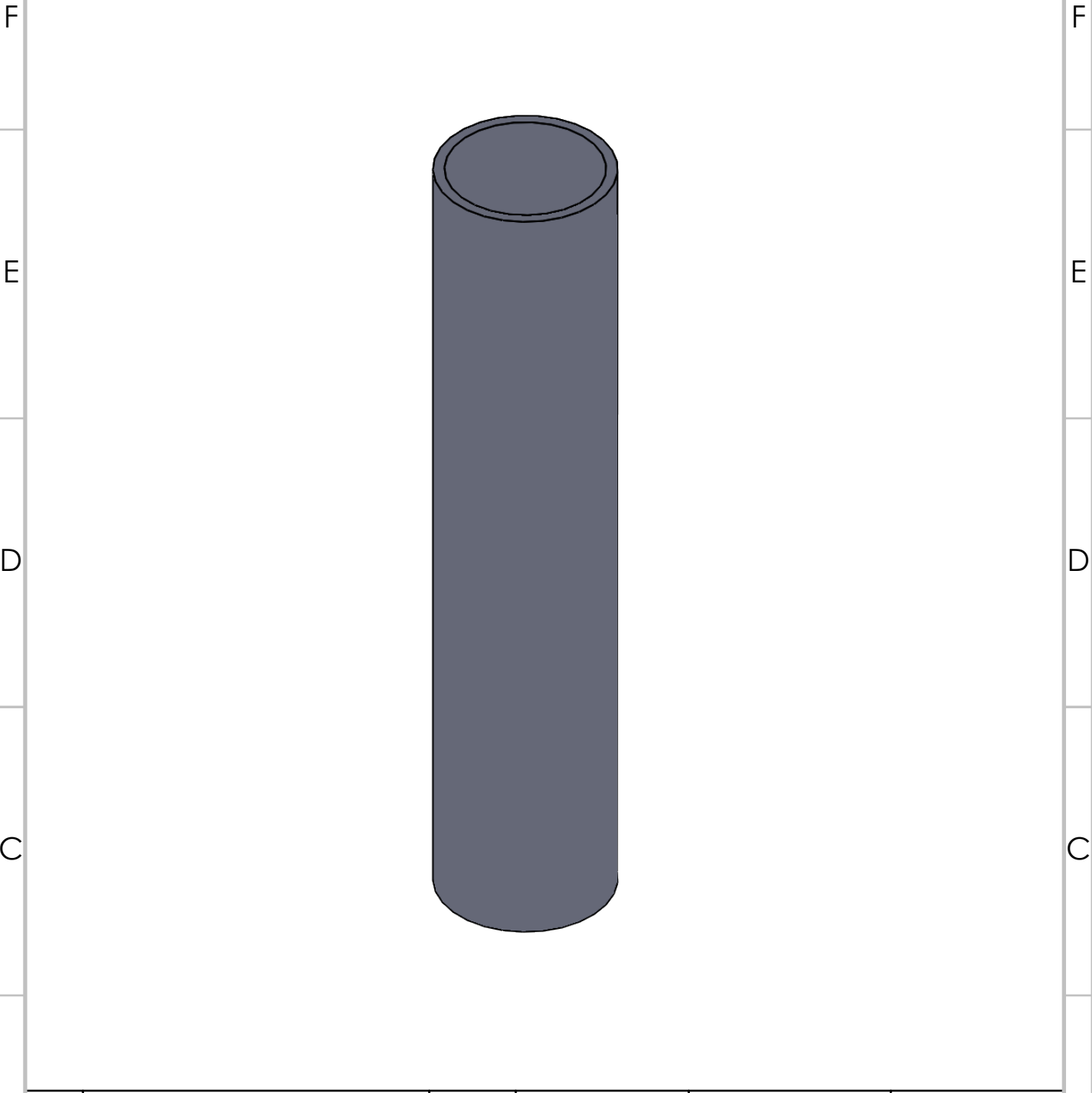

1	Pipa 6					E6	PVC	Lihat Detail	Dibeli	
B	Jml Nama Bagian					No.Id	Bahan	Ukuran	Keterangan	
	>	0	6	30	120	400	1000	Ukuran Lanjut:	No. Order:	Proyeksi:
	<	6	30	120	400	1000	2000			
	Tol	±0.1	±0.2	±0.3	±0.5	±0.8	±1.2			
A	Nama: <div style="text-align: center; font-size: 24px; font-weight: bold;">PIPA 6</div> No. Assy:							Skala 1:1	Digambar Diperiksa Disahkan	1-8-22 Rendi Radhi Bayu
	Politeknik Negeri Cilacap, Jurusan Teknik Mesin Jl. Dr. Soetomo, No. 01, Sidakaya, Cilacap, 53212 Telp: 0282-533329, E-mail: tmpnc@politeknikcilacap.ac.id							Format A4	Satuan mm	

DILARANG MENGGANDAKAN, MENYALIN, MEMINDAHKAN GAMBAR INI TANPA IZIN TERTULIS DARI POLITEKNIK NEGERI CILACAP

4		3		2		1	
No.	Perubahan	Tanggal	Nama	No.	Perubahan	Tanggal	Nama
△				△			

F

E

D

C

B

A

F

E

D

C

B

A

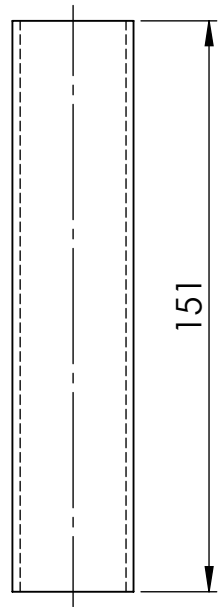
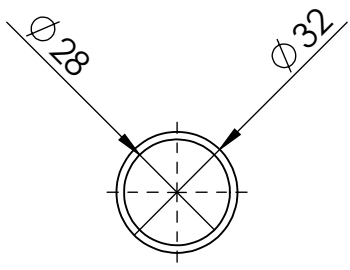

1	Pipa 6						E6	PVC	Lihat Detail	Dibeli		
>	0	6	30	120	400	1000	Ukuran Lanjut:	No. Order:	Proyeksi:			
<	6	30	120	400	1000	2000						
Tol	±0.1	±0.2	±0.3	±0.5	±0.8	±1.2						
Nama:								Skala	Digambar	1-8-22	Rendi	
PIPA 6								1:2	Diperiksa		Radhi	
No. Assy:									Disahkan		Bayu	
Politeknik Negeri Cilacap, Jurusan Teknik Mesin Jl. Dr. Soetomo, No. 01, Sidakaya, Cilacap, 53212 Telp: 0282-533329, E-mail: tmpnc@politeknikcilacap.ac.id									Format	Satuan		
								A4	mm			

4

3

2

1

No.	Perubahan	Tanggal	Nama	No.	Perubahan	Tanggal	Nama
△				△			

F

F

E

E

D

D

C

C

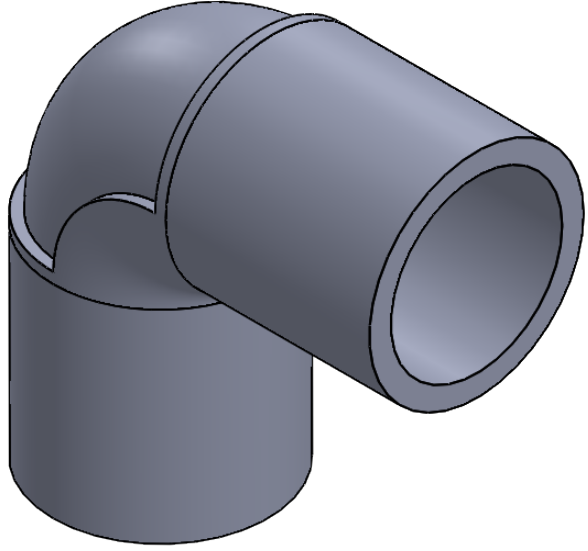

3

Elbow 90°

E7

PVC

Lihat Detail

Dibeli

B

Jml

Nama Bagian

No.Id

Bahan

Ukuran

Keterangan

B

>

0

6

30

120

400

1000

Ukuran Lanjut:

No. Order:

Proyeksi:

<

6

30

120

400

1000

2000

Tol

±0.1

±0.2

±0.3

±0.5

±0.8

±1.2

A

Nama:

ELBOW 90°

No. Assy:

Skala

1:1

Digambar

1-8-22

Rendi

Diperiksa

Radhi

Disahkan

Bayu

A



Politeknik Negeri Cilacap, Jurusan Teknik Mesin
 Jl. Dr. Soetomo, No. 01, Sidakaya, Cilacap, 53212
 Telp: 0282-533329, E-mail: tmpnc@politeknikcilacap.ac.id

Format
A4

Satuan
mm

4

3

2

1

PENGANTI DARI:

DIGANTI DENGAN

DILARANG MENGGANDAKAN, MENYALIN, MEMINDAHKAN GAMBAR INI TANPA IZIN TERTULIS DARI POLITEKNIK NEGERI CILACAP

DILARANG MENGGANDAKAN, MENYALIN, MEMINDAHTANGKAN GAMBAR INI
TANPA IZIN TERTULIS DARI POLITEKNIK NEGERI CILACAP

4		3		2		1	
No.	Perubahan	Tanggal	Nama	No.	Perubahan	Tanggal	Nama
△				△			

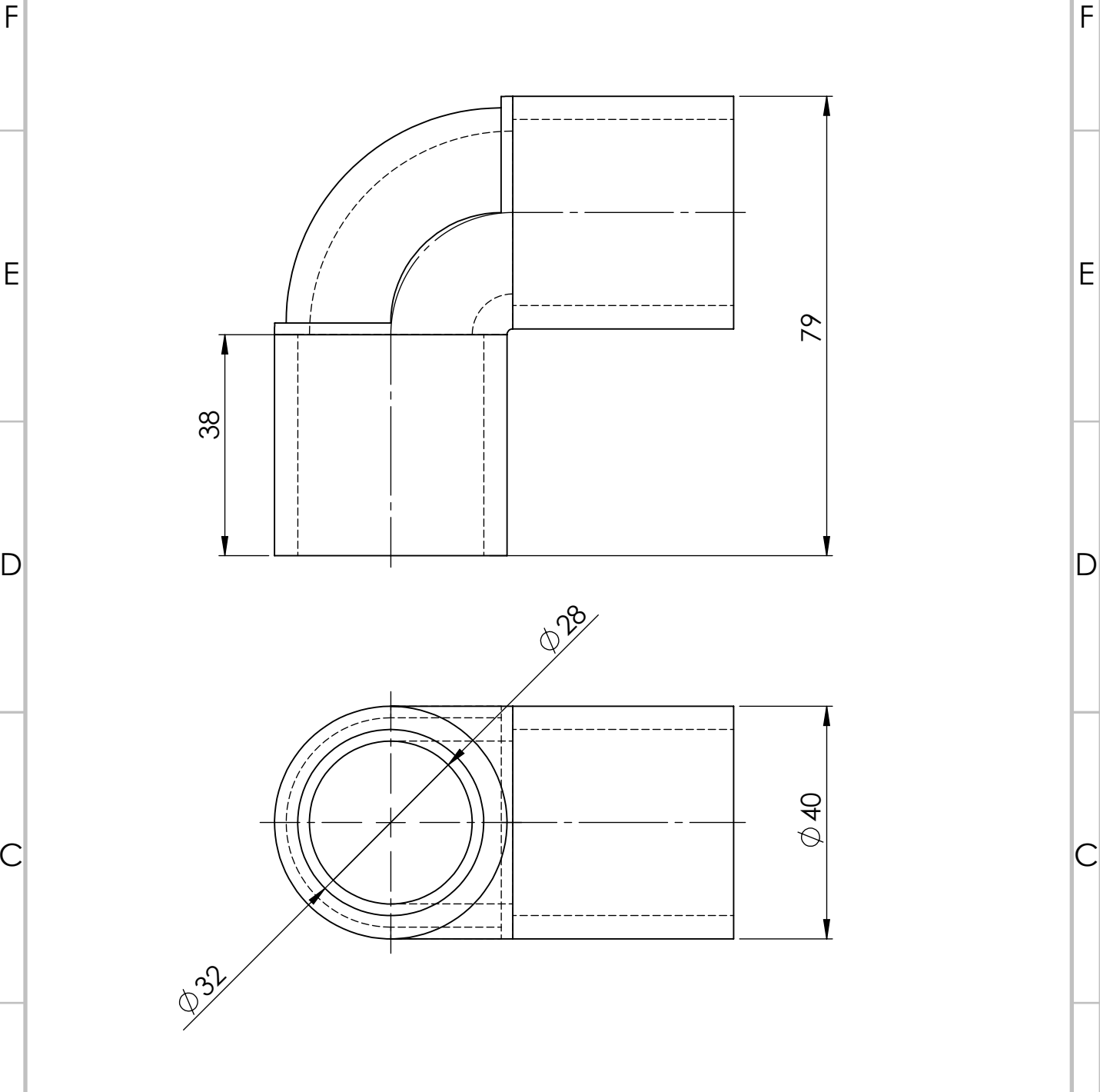

3	Elbow 90°					E7	PVC	Lihat Detail	Dibeli		
Jml	Nama Bagian					No.Id	Bahan	Ukuran	Keterangan		
>	0	6	30	120	400	1000	Ukuran Lanjut:	No. Order:	Proyeksi:		
<	6	30	120	400	1000	2000					
Tol	±0.1	±0.2	±0.3	±0.5	±0.8	±1.2					
Nama:								Skala 1:1	Digambar	1-8-22	Rendi
ELBOW 90°									Diperiksa		Radhi
									Disahkan		Bayu
No. Assy:								Format	Satuan		
Politeknik Negeri Cilacap, Jurusan Teknik Mesin Jl. Dr. Soetomo, No. 01, Sidakaya, Cilacap, 53212 Telp: 0282-533329, E-mail: tmpnc@politeknikcilacap.ac.id								A4	mm		

4

3

2

1

No.	Perubahan	Tanggal	Nama	No.	Perubahan	Tanggal	Nama
△				△			

F

F

E

E

D

D

C

C

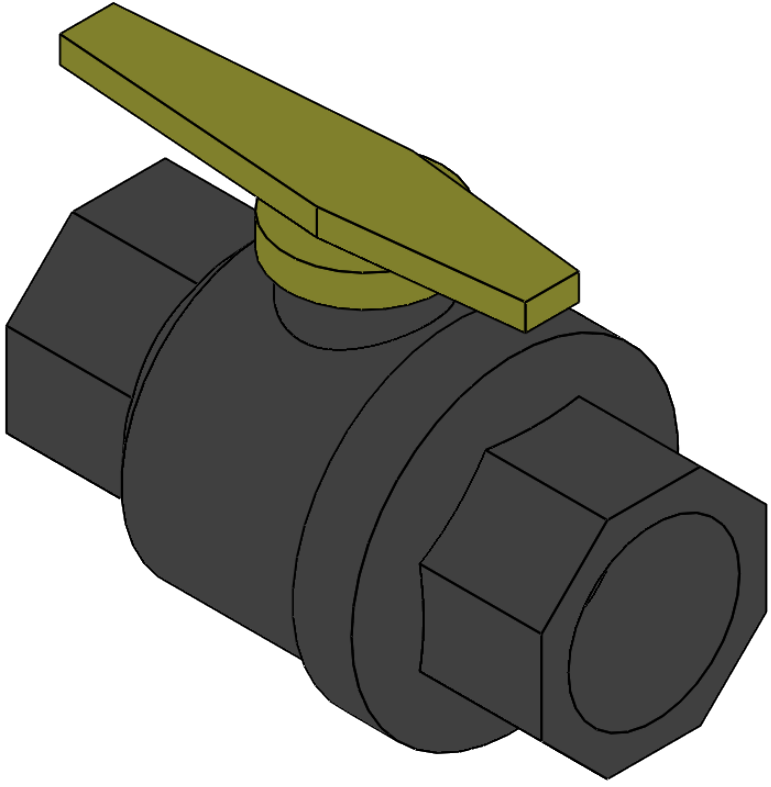

1	Ball Valve						E8	PVC	Lihat Detail	Dibeli		
B	Jml Nama Bagian						No.Id	Bahan	Ukuran	Keterangan		
	>	0	6	30	120	400	1000	Ukuran Lanjut:	No. Order:	Proyeksi:		
	<	6	30	120	400	1000	2000					
	Tol	±0.1	±0.2	±0.3	±0.5	±0.8	±1.2					

A	Nama:								Skala 1:1	Digambar	1-8-22	Rendi
	BALL VALVE									Diperiksa		Radhi
										Disahkan		Bayu
No. Assy:												

A		Politeknik Negeri Cilacap, Jurusan Teknik Mesin							Format A4	Satuan mm		
		Jl. Dr. Soetomo, No. 01, Sidakaya, Cilacap, 53212 Telp: 0282-533329, E-mail: tmpnc@politeknikcilacap.ac.id										

4

3

2

1

PENGGANTI DARI: DIGANTI DENGAN

DILARANG MENGGANDAKAN, MENYALIN, MEMINDAHTANGKAN GAMBAR INI TANPA IZIN TERTULIS DARI POLITEKNIK NEGERI CILACAP

DILARANG MENGGANDAKAN, MENYALIN, MEMINDAHTANGKAN GAMBAR INI TANPA IZIN TERTULIS DARI POLITEKNIK NEGERI CILACAP

	4	3	2	
No.	Perubahan	Tanggal	Nama	No.
△				△

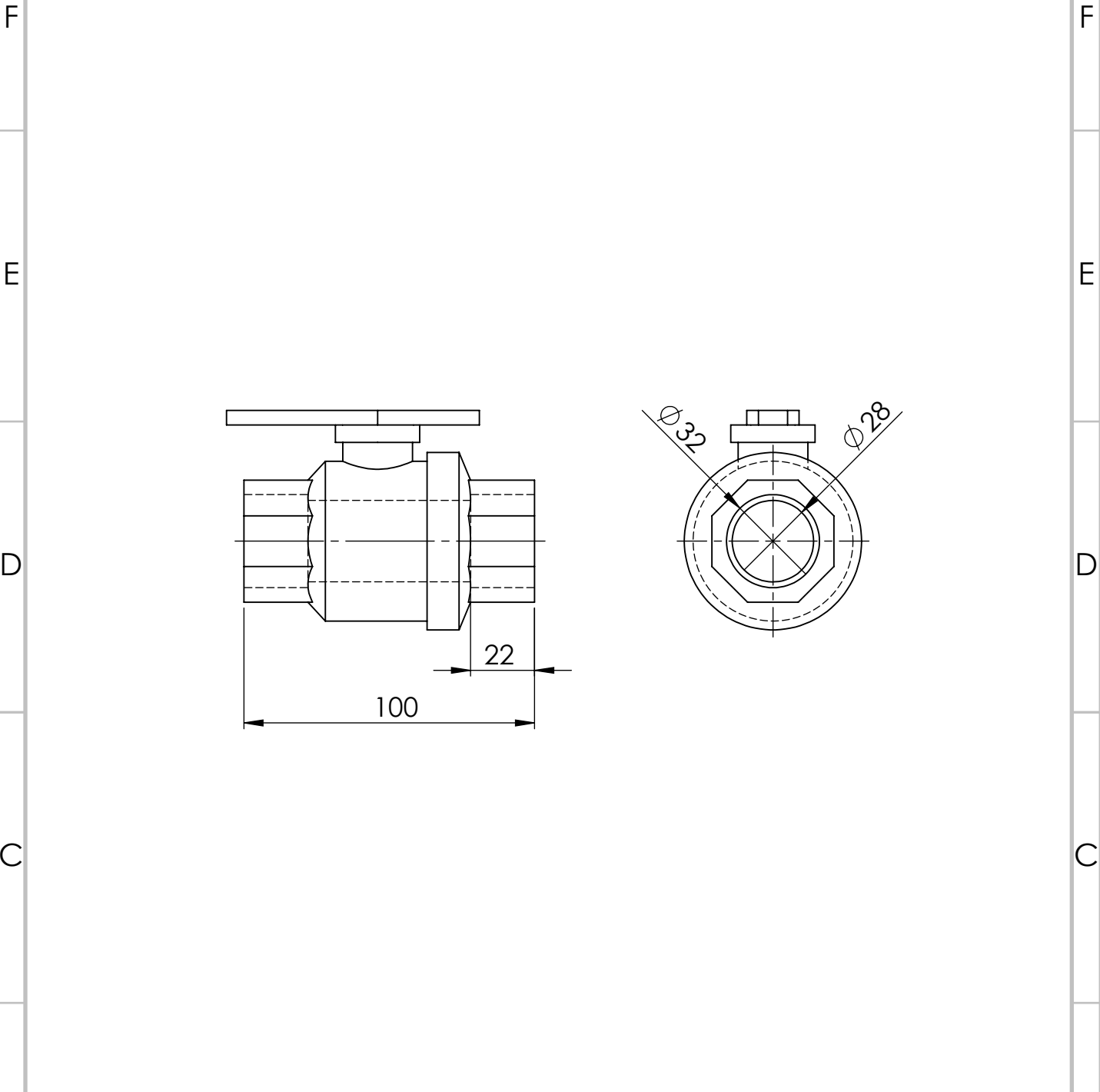

1	Ball Valve						E8	PVC	Lihat Detail	Dibeli		
>	0	6	30	120	400	1000	Ukuran Lanjut:	No. Order:	Proyeksi:			
<	6	30	120	400	1000	2000						
Tol	±0.1	±0.2	±0.3	±0.5	±0.8	±1.2						
Nama:								Skala 1:2	Digambar	1-8-22	Rendi	
BALL VALVE									Diperiksa		Radhi	
No. Assy:									Disahkan		Bayu	
Politeknik Negeri Cilacap, Jurusan Teknik Mesin Jl. Dr. Soetomo, No. 01, Sidakaya, Cilacap, 53212 Telp: 0282-533329, E-mail: tmpnc@politeknikcilacap.ac.id								Format A4	Satuan mm			

DILARANG MENGGANDAKAN, MENYALIN, MEMINDAHTANGKAN GAMBAR INI
TANPA IZIN TERTULIS DARI POLITEKNIK NEGERI CILACAP

4		3			2		1
No.	Perubahan	Tanggal	Nama	No.	Perubahan	Tanggal	Nama
△				△			

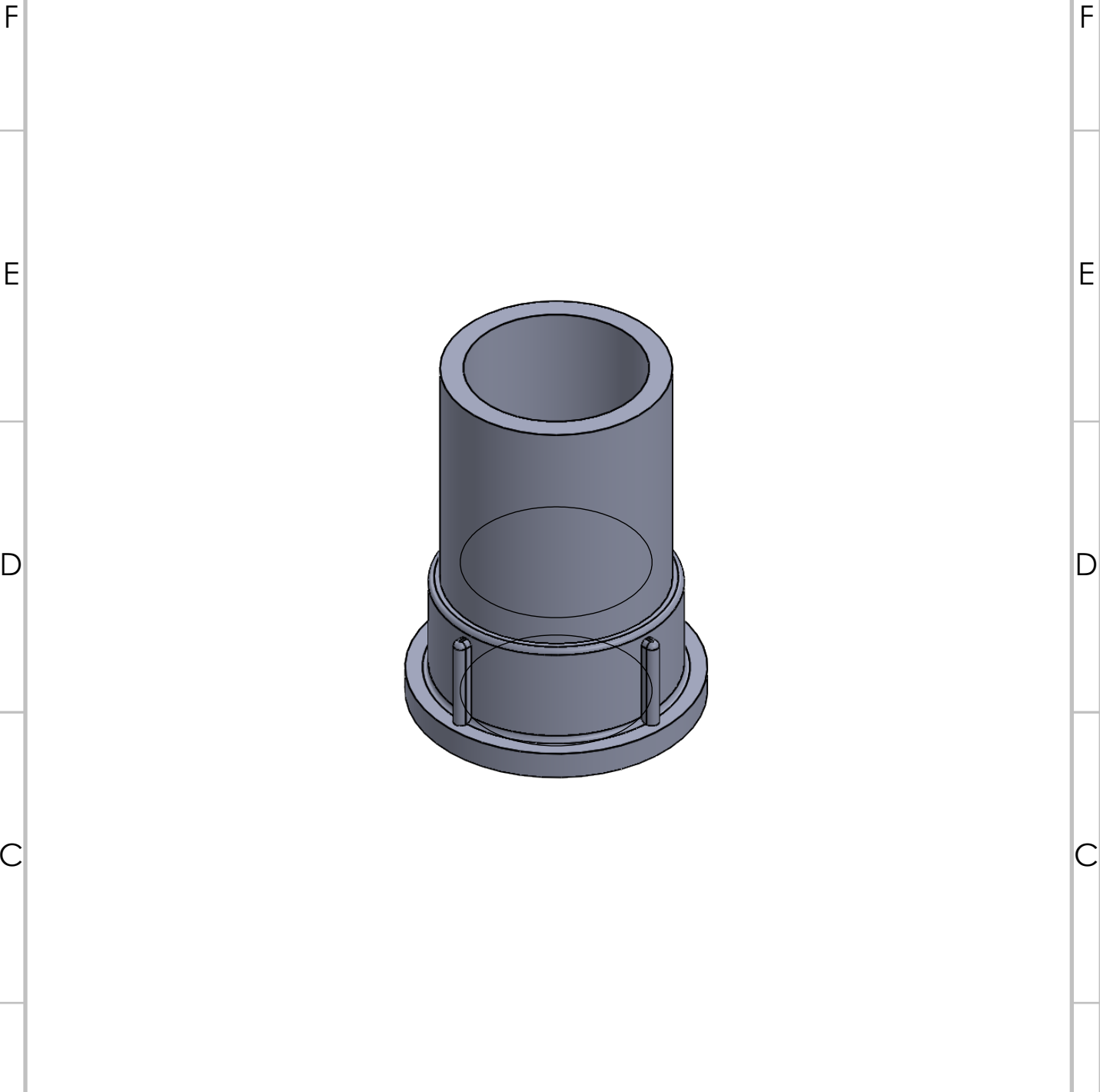

3		Faucet Socket					E9	PVC	Lihat Detail	Dibeli		
B	Jml	Nama Bagian					No.Id	Bahan	Ukuran	Keterangan		
	>	0	6	30	120	400	1000	Ukuran Lanjut:	No. Order:	Proyeksi:		
	<	6	30	120	400	1000	2000					
	Tol	±0.1	±0.2	±0.3	±0.5	±0.8	±1.2					
Nama:									Skala 1:1	Digambar	1-8-22	Rendi
FAUCET SOCKET										Diperiksa		Radhi
										Disahkan		Bayu
A	No. Assy:											
 Politeknik Negeri Cilacap, Jurusan Teknik Mesin Jl. Dr. Soetomo, No. 01, Sidakaya, Cilacap, 53212 Telp: 0282-533329, E-mail: tmpnc@politeknikcilacap.ac.id									Format A4	Satuan mm		

4			3			2			1
No.	Perubahan	Tanggal	Nama	No.	Perubahan	Tanggal	Nama		
△				△					

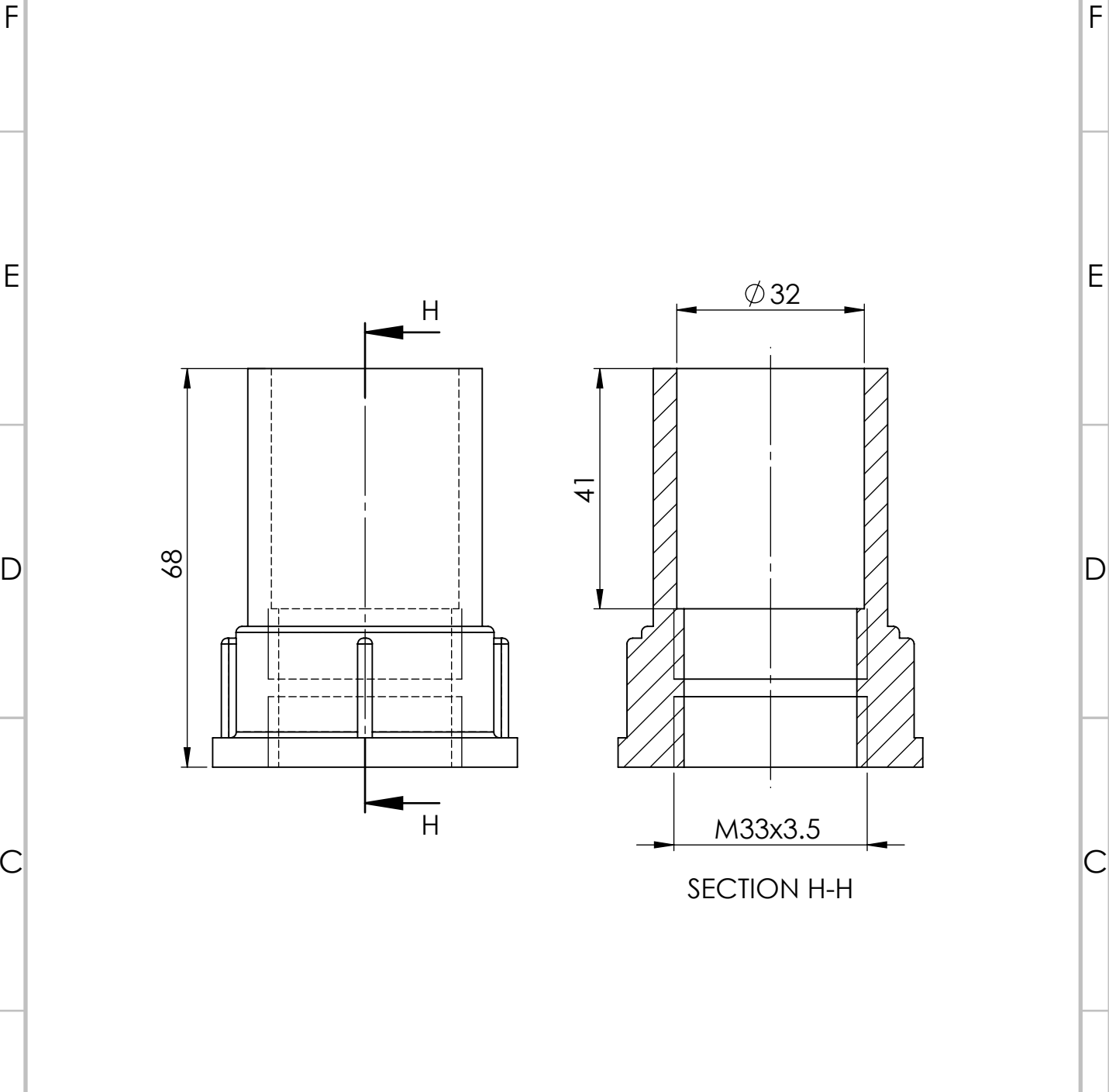

3	Faucet Socket						E9	PVC	Lihat Detail	Dibeli	
Jml	Nama Bagian						No.Id	Bahan	Ukuran	Keterangan	
>	0	6	30	120	400	1000	Ukuran Lanjut:	No. Order:	Proyeksi:		
<	6	30	120	400	1000	2000					
Tol	±0.1	±0.2	±0.3	±0.5	±0.8	±1.2					

Nama:								Skala 1:1	Digambar	1-8-22	Rendi
FAUCET SOCKET									Diperiksa		Radhi
									Disahkan		Bayu
No. Assy:											

 Politeknik Negeri Cilacap, Jurusan Teknik Mesin Jl. Dr. Soetomo, No. 01, Sidakaya, Cilacap, 53212 Telp: 0282-533329, E-mail: tmpnc@politeknikcilacap.ac.id								Format A4	Satuan mm		
---	--	--	--	--	--	--	--	--------------	--------------	--	--

DILARANG MENGGANDAKAN, MENYALIN, MEMINDAHTANGKAN GAMBAR INI TANPA IZIN TERTULIS DARI POLITEKNIK NEGERI CILACAP

DILARANG MENGGANDAKAN, MENYALIN, MEMINDAHTANGKAN GAMBAR INI TANPA IZIN TERTULIS DARI POLITEKNIK NEGERI CILACAP

4		3			2		1
No.	Perubahan	Tanggal	Nama	No.	Perubahan	Tanggal	Nama
△				△			

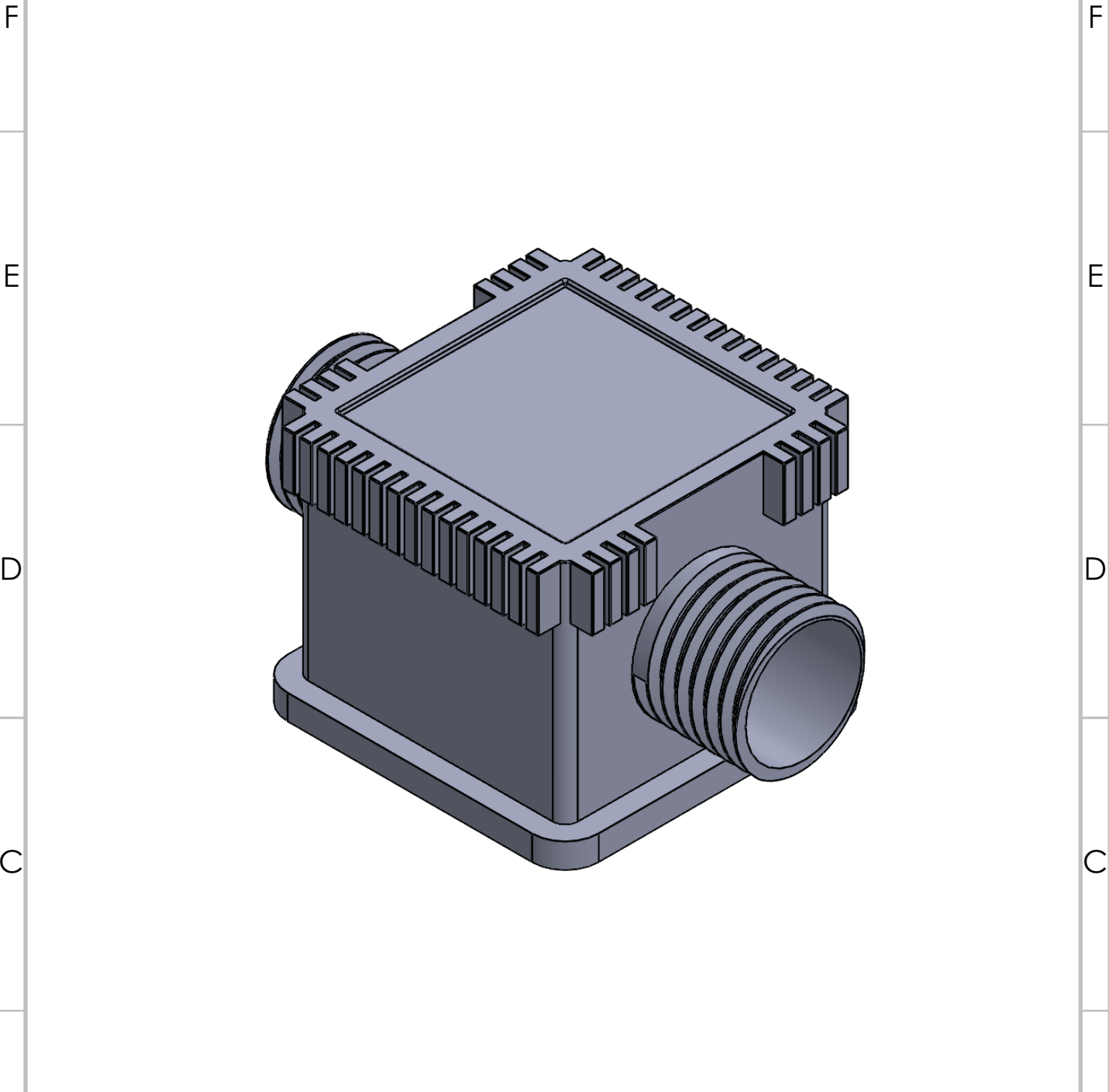

1	Flow Meter Digital					E10	-	Lihat Detail	Dibeli
Jml	Nama Bagian					No.Id	Bahan	Ukuran	Keterangan
>	0	6	30	120	400	1000	Ukuran Lanjut:	No. Order:	Proyeksi:
<	6	30	120	400	1000	2000			
Tol	±0.1	±0.2	±0.3	±0.5	±0.8	±1.2			

Nama:							Skala 1:1	Digambar	1-8-22	Rendi
FLOW METER DIGITAL								Diperiksa		Radhi
								Disahkan		Bayu
No. Assy:										

 Politeknik Negeri Cilacap, Jurusan Teknik Mesin Jl. Dr. Soetomo, No. 01, Sidakaya, Cilacap, 53212 Telp: 0282-533329, E-mail: tmpnc@politeknikcilacap.ac.id							Format A4	Satuan mm		
---	--	--	--	--	--	--	----------------------------	----------------------------	--	--

DILARANG MENGGANDAKAN, MENYALIN, MEMINDAHTANGKAN GAMBAR INI
TANPA IZIN TERTULIS DARI POLITEKNIK NEGERI CILACAP

4		3		2		1	
No.	Perubahan	Tanggal	Nama	No.	Perubahan	Tanggal	Nama
△				△			

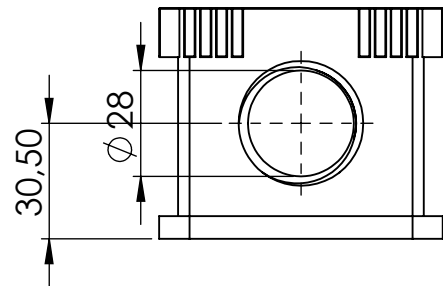
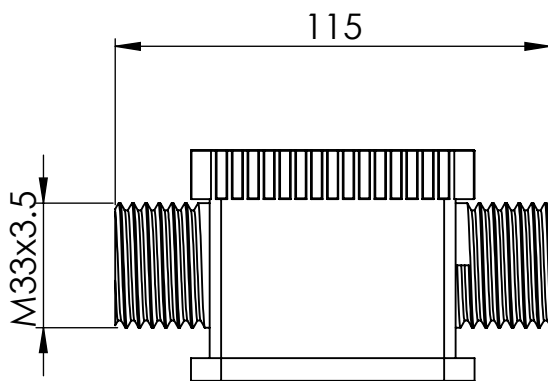

1	Flow Meter Digital					E10	-	Lihat Detail	Dibeli		
Jml	Nama Bagian					No.Id	Bahan	Ukuran	Keterangan		
>	0	6	30	120	400	1000	Ukuran Lanjut:	No. Order:	Proyeksi: 		
<	6	30	120	400	1000	2000					
Tol	±0.1	±0.2	±0.3	±0.5	±0.8	±1.2					
Nama:								Skala 1:2	Digambar	1-8-22	Rendi
FLOW METER DIGITAL									Diperiksa		Radhi
									Disahkan		Bayu
No. Assy:								Format A4	Satuan mm		
Politeknik Negeri Cilacap, Jurusan Teknik Mesin Jl. Dr. Soetomo, No. 01, Sidakaya, Cilacap, 53212 Telp: 0282-533329, E-mail: tmpnc@politeknikcilacap.ac.id											

LAMPIRAN 13

Transmisi

4		3		2		1	
No.	Perubahan	Tanggal	Nama	No.	Perubahan	Tanggal	Nama
△				△			

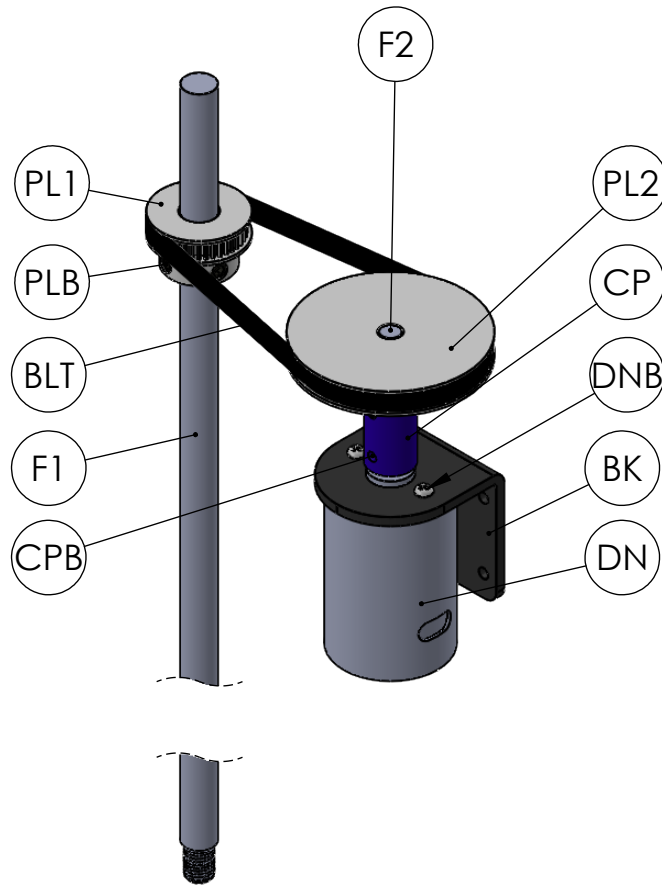





1	Timing Pulley 80T	PL2	Al Alloy	Lihat Detail	Dibeli
1	Timing Pulley 40T	PL1	Al Alloy	Lihat Detail	Dibeli
1	Converter Shaft	F2	S45C	Lihat Detail	Dibeli
1	Turbine Shaft	F1	S45C	Lihat Detail	Dibuat
2	Coupling Bolt	CPB	Mild Steel	Lihat Detail	Dibeli
2	Dynamo Bolt	DNB	Mild Steel	Lihat Detail	Dibeli
1	Timing Belt	BLT	Rubber	Lihat Detail	Dibeli
4	Pulley Bolt	PLB	Mild Steel	Lihat Detail	Dibeli
1	Coupling	CP	Al Alloy	Lihat Detail	Dibeli
1	Bracket	BK	Mild Steel	Lihat Detail	Dibeli
1	Dynamo	DN	-	Lihat Detail	Dibeli

B	Jml	Nama Bagian					No.Id	Bahan	Ukuran	Keterangan	B
	>	0	6	30	120	400	1000	Ukuran Lanjut:	No. Order:	Proyeksi:	
	<	6	30	120	400	1000	2000				
	Tol	±0.1	±0.2	±0.3	±0.5	±0.8	±1.2				

A	Nama:	SUB ASSEMBLY TRANSMISSION	Skala 1:5	Digambar	1-8-22	Rendi
	No. Assy:			Diperiksa		Radhi
				Disahkan		Bayu

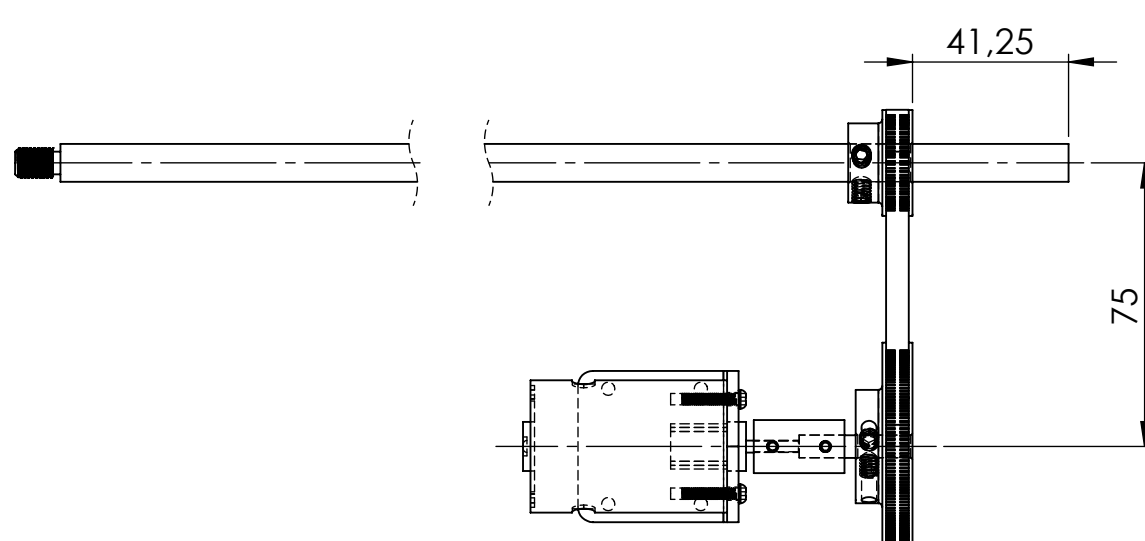
A	 Politeknik Negeri Cilacap, Jurusan Teknik Mesin Jl. Dr. Soetomo, No. 01, Sidakaya, Cilacap, 53212 Telp: 0282-533329, E-mail: tmpnc@politeknikcilacap.ac.id	Format	Satuan		
		A4	mm		

DILARANG MENGGANDAKAN, MENYALIN, MEMINDAHKANKAN GAMBAR INI TANPA IZIN TERTULIS DARI POLITEKNIK NEGERI CILAPAC

	4		3		2		1																																																																		
No.	Perubahan	Tanggal	Nama	No.	Perubahan	Tanggal	Nama																																																																		
△				△																																																																					
F							F																																																																		
E							E																																																																		
D							D																																																																		
C	<table border="1" style="width: 100%; border-collapse: collapse;"> <tr> <td style="width: 5%;">1</td> <td style="width: 40%;">Timing Pulley 80T</td> <td style="width: 10%;">PL2</td> <td style="width: 15%;">Al Alloy</td> <td style="width: 15%;">Lihat Detail</td> <td style="width: 15%;">Dibeli</td> </tr> <tr> <td>1</td> <td>Timing Pulley 40T</td> <td>PL1</td> <td>Al Alloy</td> <td>Lihat Detail</td> <td>Dibeli</td> </tr> <tr> <td>1</td> <td>Converter Shaft</td> <td>F2</td> <td>S45C</td> <td>Lihat Detail</td> <td>Dibeli</td> </tr> <tr> <td>1</td> <td>Turbine Shaft</td> <td>F1</td> <td>S45C</td> <td>Lihat Detail</td> <td>Dibuat</td> </tr> <tr> <td>2</td> <td>Coupling Bolt</td> <td>CPB</td> <td>Mild Steel</td> <td>Lihat Detail</td> <td>Dibeli</td> </tr> <tr> <td>2</td> <td>Dynamo Bolt</td> <td>DNB</td> <td>Mild Steel</td> <td>Lihat Detail</td> <td>Dibeli</td> </tr> <tr> <td>1</td> <td>Timing Belt</td> <td>BLT</td> <td>Rubber</td> <td>Lihat Detail</td> <td>Dibeli</td> </tr> <tr> <td>4</td> <td>Pulley Bolt</td> <td>PLB</td> <td>Mild Steel</td> <td>Lihat Detail</td> <td>Dibeli</td> </tr> <tr> <td>1</td> <td>Coupling</td> <td>CP</td> <td>Al Alloy</td> <td>Lihat Detail</td> <td>Dibeli</td> </tr> <tr> <td>1</td> <td>Bracket</td> <td>BK</td> <td>Mild Steel</td> <td>Lihat Detail</td> <td>Dibeli</td> </tr> <tr> <td>1</td> <td>Dynamo</td> <td>DN</td> <td>-</td> <td>Lihat Detail</td> <td>Dibeli</td> </tr> </table>						1	Timing Pulley 80T	PL2	Al Alloy	Lihat Detail	Dibeli	1	Timing Pulley 40T	PL1	Al Alloy	Lihat Detail	Dibeli	1	Converter Shaft	F2	S45C	Lihat Detail	Dibeli	1	Turbine Shaft	F1	S45C	Lihat Detail	Dibuat	2	Coupling Bolt	CPB	Mild Steel	Lihat Detail	Dibeli	2	Dynamo Bolt	DNB	Mild Steel	Lihat Detail	Dibeli	1	Timing Belt	BLT	Rubber	Lihat Detail	Dibeli	4	Pulley Bolt	PLB	Mild Steel	Lihat Detail	Dibeli	1	Coupling	CP	Al Alloy	Lihat Detail	Dibeli	1	Bracket	BK	Mild Steel	Lihat Detail	Dibeli	1	Dynamo	DN	-	Lihat Detail	Dibeli	C
1	Timing Pulley 80T	PL2	Al Alloy	Lihat Detail	Dibeli																																																																				
1	Timing Pulley 40T	PL1	Al Alloy	Lihat Detail	Dibeli																																																																				
1	Converter Shaft	F2	S45C	Lihat Detail	Dibeli																																																																				
1	Turbine Shaft	F1	S45C	Lihat Detail	Dibuat																																																																				
2	Coupling Bolt	CPB	Mild Steel	Lihat Detail	Dibeli																																																																				
2	Dynamo Bolt	DNB	Mild Steel	Lihat Detail	Dibeli																																																																				
1	Timing Belt	BLT	Rubber	Lihat Detail	Dibeli																																																																				
4	Pulley Bolt	PLB	Mild Steel	Lihat Detail	Dibeli																																																																				
1	Coupling	CP	Al Alloy	Lihat Detail	Dibeli																																																																				
1	Bracket	BK	Mild Steel	Lihat Detail	Dibeli																																																																				
1	Dynamo	DN	-	Lihat Detail	Dibeli																																																																				
B	<table border="1" style="width: 100%; border-collapse: collapse;"> <tr> <th style="width: 5%;">Jml</th> <th colspan="6" style="width: 40%;">Nama Bagian</th> <th style="width: 10%;">No.Id</th> <th style="width: 15%;">Bahan</th> <th style="width: 15%;">Ukuran</th> <th style="width: 5%;">Keterangan</th> </tr> <tr> <td style="text-align: center;">></td> <td style="text-align: center;">0</td> <td style="text-align: center;">6</td> <td style="text-align: center;">30</td> <td style="text-align: center;">120</td> <td style="text-align: center;">400</td> <td style="text-align: center;">1000</td> <td colspan="2" rowspan="3" style="vertical-align: top;">Ukuran Lanjut:</td> <td rowspan="3" style="vertical-align: top;">No. Order:</td> <td rowspan="3" style="vertical-align: top;">Proyeksi:</td> </tr> <tr> <td style="text-align: center;"><</td> <td style="text-align: center;">6</td> <td style="text-align: center;">30</td> <td style="text-align: center;">120</td> <td style="text-align: center;">400</td> <td style="text-align: center;">1000</td> <td style="text-align: center;">2000</td> </tr> <tr> <td style="text-align: center;">Tol</td> <td style="text-align: center;">±0.1</td> <td style="text-align: center;">±0.2</td> <td style="text-align: center;">±0.3</td> <td style="text-align: center;">±0.5</td> <td style="text-align: center;">±0.8</td> <td style="text-align: center;">±1.2</td> </tr> </table>						Jml	Nama Bagian						No.Id	Bahan	Ukuran	Keterangan	>	0	6	30	120	400	1000	Ukuran Lanjut:		No. Order:	Proyeksi:	<	6	30	120	400	1000	2000	Tol	±0.1	±0.2	±0.3	±0.5	±0.8	±1.2	B																														
Jml	Nama Bagian						No.Id	Bahan	Ukuran	Keterangan																																																															
>	0	6	30	120	400	1000	Ukuran Lanjut:		No. Order:	Proyeksi:																																																															
<	6	30	120	400	1000	2000																																																																			
Tol	±0.1	±0.2	±0.3	±0.5	±0.8	±1.2																																																																			
A	<table border="1" style="width: 100%; border-collapse: collapse;"> <tr> <td style="width: 60%;"> Nama: <h2 style="text-align: center;">SUB ASSEMBLY TRANSMISSION</h2> No. Assy: </td> <td style="width: 10%; text-align: center;"> Skala <h3 style="text-align: center;">1:5</h3> </td> <td style="width: 15%;"> Digambar 1-8-22 Diperiksa Disahkan </td> <td style="width: 15%;"> Rendi Radhi Bayu </td> </tr> <tr> <td>  Politeknik Negeri Cilacap, Jurusan Teknik Mesin Jl. Dr. Soetomo, No. 01, Sidakaya, Cilacap, 53212 Telp: 0282-533329, E-mail: tmpnc@politeknikcilacap.ac.id </td> <td style="text-align: center;"> Format <h3 style="text-align: center;">A4</h3> </td> <td style="text-align: center;"> Satuan <h3 style="text-align: center;">mm</h3> </td> <td></td> </tr> </table>						Nama: <h2 style="text-align: center;">SUB ASSEMBLY TRANSMISSION</h2> No. Assy:	Skala <h3 style="text-align: center;">1:5</h3>	Digambar 1-8-22 Diperiksa Disahkan	Rendi Radhi Bayu	 Politeknik Negeri Cilacap, Jurusan Teknik Mesin Jl. Dr. Soetomo, No. 01, Sidakaya, Cilacap, 53212 Telp: 0282-533329, E-mail: tmpnc@politeknikcilacap.ac.id	Format <h3 style="text-align: center;">A4</h3>	Satuan <h3 style="text-align: center;">mm</h3>		A																																																										
Nama: <h2 style="text-align: center;">SUB ASSEMBLY TRANSMISSION</h2> No. Assy:	Skala <h3 style="text-align: center;">1:5</h3>	Digambar 1-8-22 Diperiksa Disahkan	Rendi Radhi Bayu																																																																						
 Politeknik Negeri Cilacap, Jurusan Teknik Mesin Jl. Dr. Soetomo, No. 01, Sidakaya, Cilacap, 53212 Telp: 0282-533329, E-mail: tmpnc@politeknikcilacap.ac.id	Format <h3 style="text-align: center;">A4</h3>	Satuan <h3 style="text-align: center;">mm</h3>																																																																							

4

3

2

1

No.	Perubahan	Tanggal	Nama	No.	Perubahan	Tanggal	Nama
△				△			

F

F

E

E

D

D

C

C

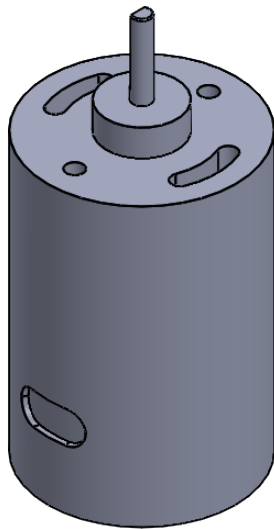

1	Dynamo						DN	-	Lihat Detail	Dibeli
B	Jml Nama Bagian						No.Id	Bahan	Ukuran	Keterangan
>	0	6	30	120	400	1000	Ukuran Lanjut:	No. Order:	Proyeksi:	
<	6	30	120	400	1000	2000				
Tol	±0.1	±0.2	±0.3	±0.5	±0.8	±1.2				

A	Nama:	DYNAMO	Skala 1:1	Digambar	1-8-22	Rendi
	No. Assy:			Diperiksa		Radhi
				Disahkan		Bayu

A



Politeknik Negeri Cilacap, Jurusan Teknik Mesin
 Jl. Dr. Soetomo, No. 01, Sidakaya, Cilacap, 53212
 Telp: 0282-533329, E-mail: tmpnc@politeknikcilacap.ac.id

Format
A4

Satuan
mm

4

3

2

1

	4	3	2				
No.	Perubahan	Tanggal	Nama	No.	Perubahan	Tanggal	Nama
△				△			

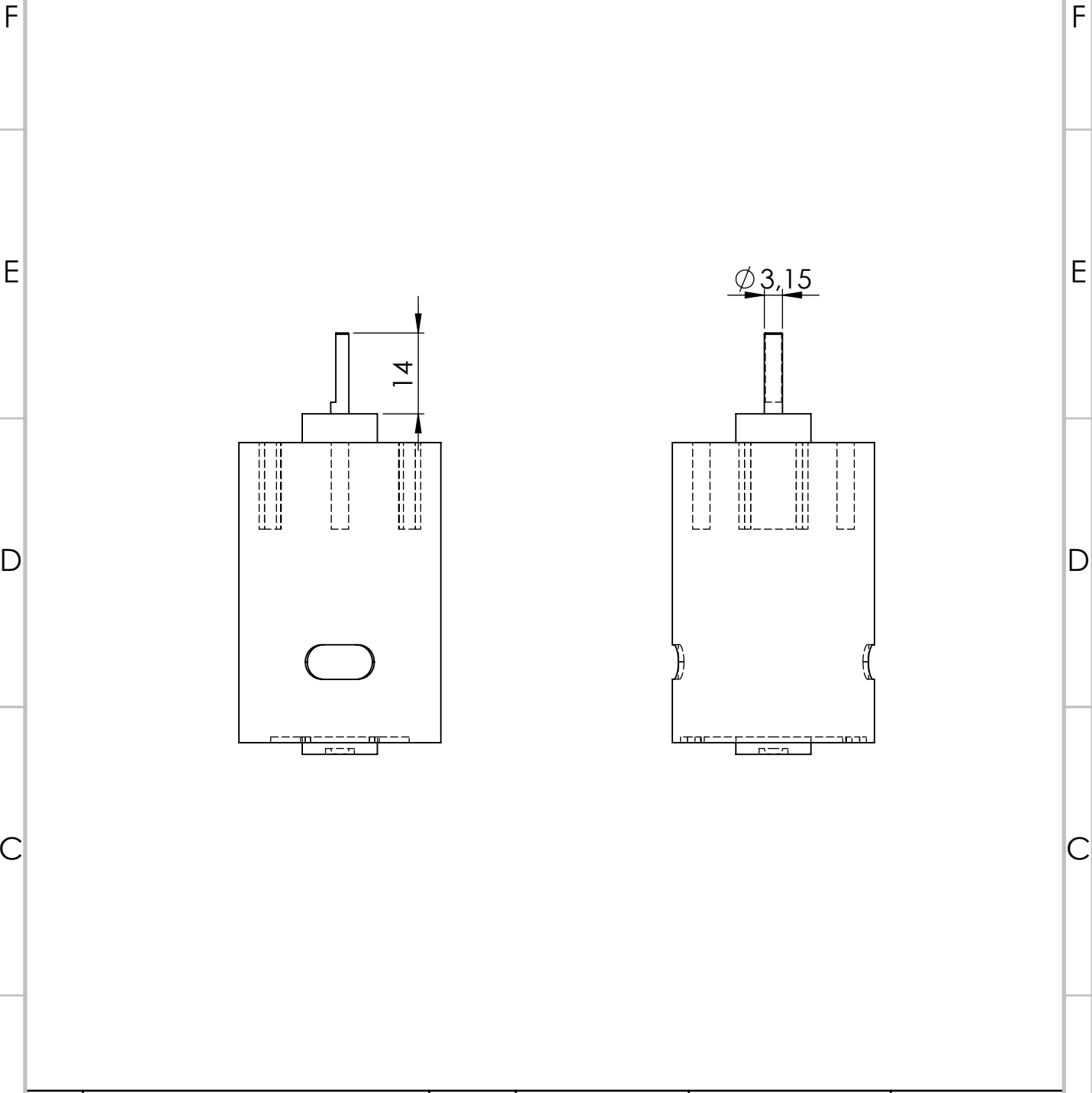

1	Dynamo						DN	-	Lihat Detail	Dibeli			
B	Jml Nama Bagian						No.Id	Bahan	Ukuran	Keterangan			
	>	0	6	30	120	400	1000	Ukuran Lanjut:	No. Order:	Proyeksi: 			
	<	6	30	120	400	1000	2000						
	Tol	±0.1	±0.2	±0.3	±0.5	±0.8	±1.2						
A	Nama: <h2 style="text-align: center;">DYNAMO</h2>								Skala 1:1	Digambar	1-8-22	Rendi	
	No. Assy:									Diperiksa		Radhi	
										Disahkan		Bayu	
									Format	Satuan			
	Politeknik Negeri Cilacap, Jurusan Teknik Mesin								A4	mm			
	Jl. Dr. Soetomo, No. 01, Sidakaya, Cilacap, 53212												
	Telp: 0282-533329, E-mail: tmpnc@politeknikcilacap.ac.id												

4

3

2

1

No.	Perubahan	Tanggal	Nama	No.	Perubahan	Tanggal	Nama
△				△			

F

F

E

E

D

D

C

C



B

B

1	Bracket						BK	Mild Steel	Lihat Detail	Dibeli
Jml	Nama Bagian						No.Id	Bahan	Ukuran	Keterangan
>	0	6	30	120	400	1000	Ukuran Lanjut:	No. Order:	Proyeksi:	
<	6	30	120	400	1000	2000				
Tol	±0.1	±0.2	±0.3	±0.5	±0.8	±1.2				

A

A

Nama:

BRACKET

No. Assy:

Skala 2:1	Digambar	1-8-22	Rendi
	Diperiksa		Radhi
	Disahkan		Bayu



Politeknik Negeri Cilacap, Jurusan Teknik Mesin
 Jl. Dr. Soetomo, No. 01, Sidakaya, Cilacap, 53212
 Telp: 0282-533329, E-mail: tmpnc@politeknikcilacap.ac.id

Format
A4

Satuan
mm

4

3

2

1

4		3		2			
No.	Perubahan	Tanggal	Nama	No.	Perubahan	Tanggal	Nama
△				△			

F

F

E

E

D

D

C

C

A

A

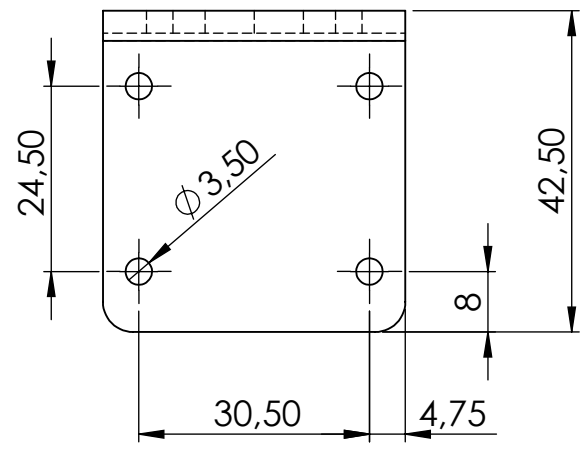
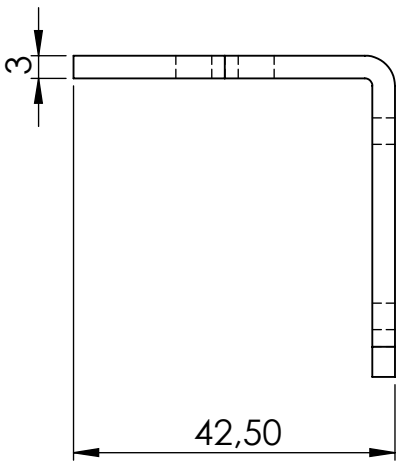
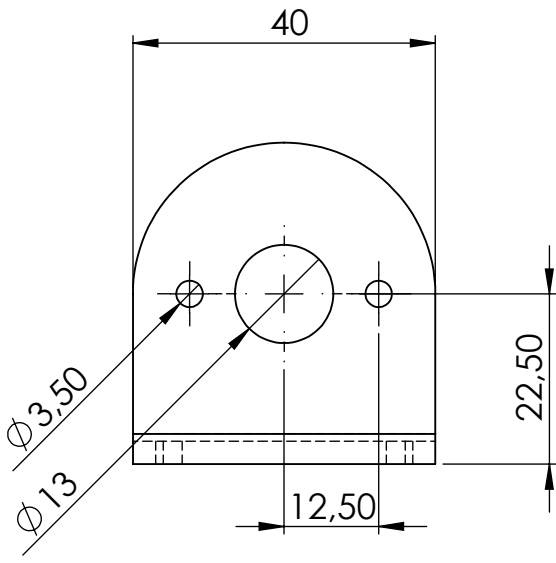

1	Bracket	BK	Mild Steel	Lihat Detail	Dibeli
>	0 6 30 120 400 1000	No.Id	Bahan	Ukuran	Keterangan
<	6 30 120 400 1000 2000	Ukuran Lanjut:		No. Order:	Proyeksi:
Tol	±0.1 ±0.2 ±0.3 ±0.5 ±0.8 ±1.2				

Nama: <div style="text-align:center; font-size: 24pt; font-weight: bold; margin: 10px 0;">BRACKET</div> No. Assy:	Skala 1:1	Digambar 1-8-22	Rendy
		Diperiksa	Radhi
		Disahkan	Bayu

Politeknik Negeri Cilacap, Jurusan Teknik Mesin Jl. Dr. Soetomo, No. 01, Sidakaya, Cilacap, 53212 Telp: 0282-533329, E-mail: tmpnc@politeknikcilacap.ac.id	Format A4	Satuan mm	
---	----------------------------	----------------------------	--

DILARANG MENGGANDAKAN, MENYALIN, MEMINDAHTANGKAN GAMBAR INI TANPA IZIN TERTULIS DARI POLITEKNIK NEGERI CILACAP

4

3

2

1

No.	Perubahan	Tanggal	Nama	No.	Perubahan	Tanggal	Nama
△				△			

F

F

E

E

D

D

C

C

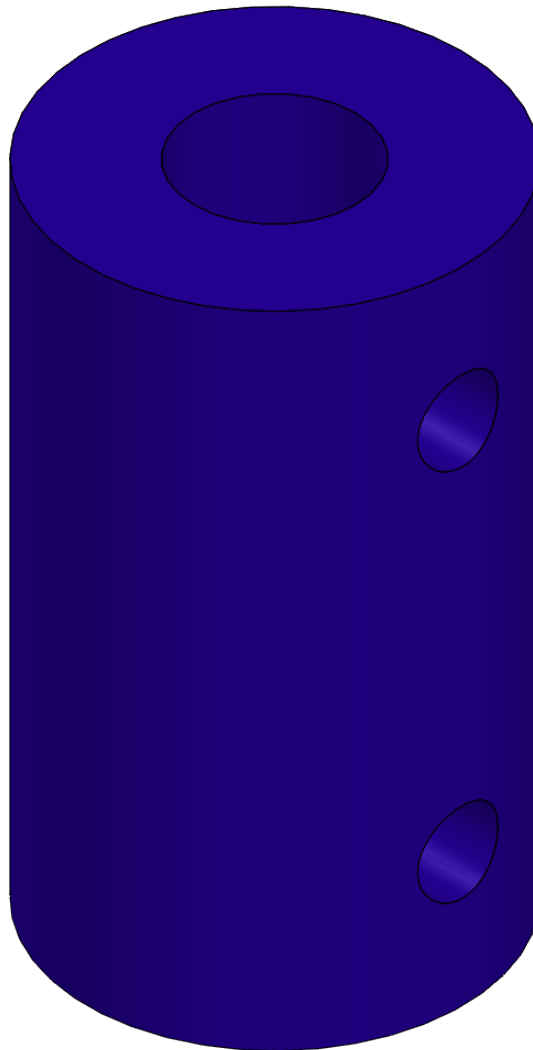

1	Coupling						CP	Mild Steel	Lihat Detail	Dibeli
B	Jml Nama Bagian						No.Id	Bahan	Ukuran	Keterangan
	>	0	6	30	120	400	1000	Ukuran Lanjut:	No. Order:	Proyeksi:
	<	6	30	120	400	1000	2000			
	Tol	±0.1	±0.2	±0.3	±0.5	±0.8	±1.2			

A	Nama:							Skala 5:1	Digambar	1-8-22	Rendi
	COUPLING								Diperiksa		Radhi
									Disahkan		Bayu
No. Assy:											

 Politeknik Negeri Cilacap, Jurusan Teknik Mesin Jl. Dr. Soetomo, No. 01, Sidakaya, Cilacap, 53212 Telp: 0282-533329, E-mail: tmpnc@politeknikcilacap.ac.id							Format A4	Satuan mm		
---	--	--	--	--	--	--	----------------------------	----------------------------	--	--

4

3

2

1

PENGANTI DARI:

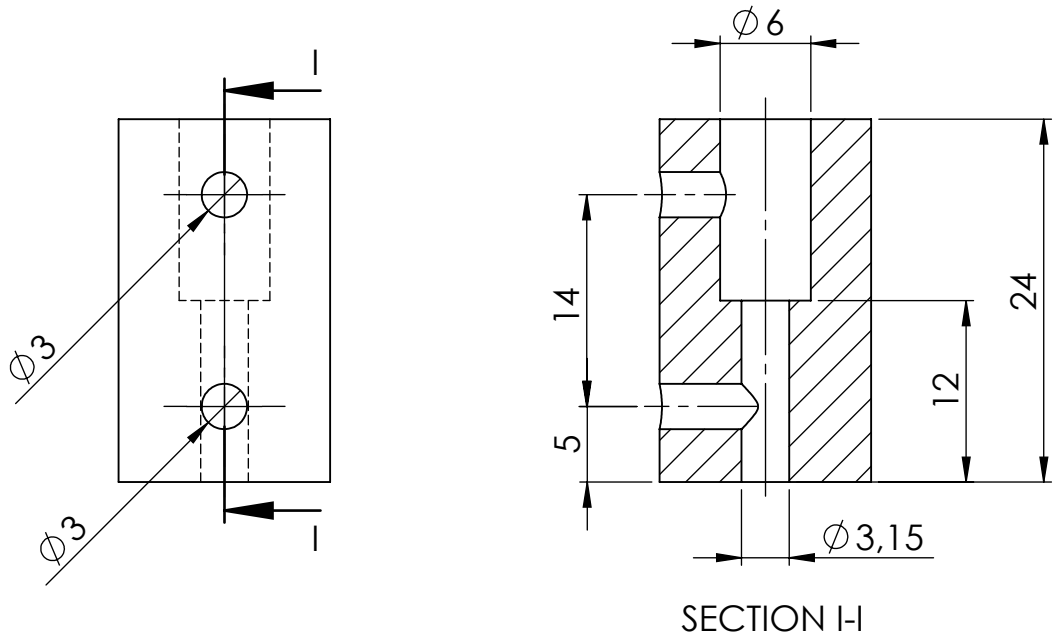

DIGANTI DENGAN

4		3		2		1	
No.	Perubahan	Tanggal	Nama	No.	Perubahan	Tanggal	Nama
△				△			

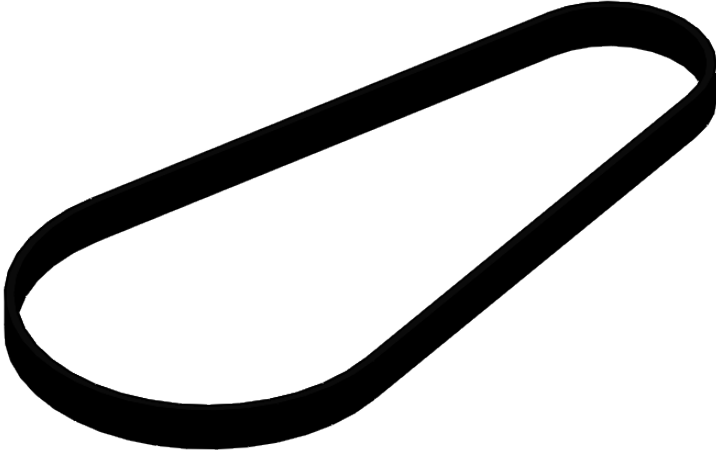

1	Coupling						CP	Mild Steel	Lihat Detail	Dibeli		
B	Jml	Nama Bagian					No.Id	Bahan	Ukuran	Keterangan		
	>	0	6	30	120	400	1000	Ukuran Lanjut:	No. Order:	Proyeksi:		
	<	6	30	120	400	1000	2000					
	Tol	± 0.1	± 0.2	± 0.3	± 0.5	± 0.8	± 1.2					
A	<p>Nama:</p> <h2 style="text-align: center;">COUPLING</h2> <p>No. Assy:</p>								Skala 2:1	Digambar	1-8-22	Rendi
								Diperiksa			Radhi	
								Disahkan			Bayu	
								Format A4	Satuan mm			

DILARANG MENGGANDAKAN, MENYALIN, MEMINDAH TANGKANKAN GAMBAR INI TANPA IZIN TERTULIS DARI POLITEKNIK NEGERI CILACAP

4				3			2		1		
No.	Perubahan			Tanggal	Nama	No.	Perubahan		Tanggal	Nama	
△						△					
F											F
E											E
D											D
C											C
B											B
A											A
1	Timing Belt					BLT	Rubber	272 mm length	Dibeli		
Jml	Nama Bagian					No.Id	Bahan	Ukuran	Keterangan		
>	0	6	30	120	400	1000	Ukuran Lanjut:	No. Order:	Proyeksi:		
<	6	30	120	400	1000	2000					
Tol	±0.1	±0.2	±0.3	±0.5	±0.8	±1.2					
Nama:							Skala 1:1	Digambar	1-8-22	Rendi	
TIMING BELT								Diperiksa		Radhi	
								Disahkan		Bayu	
No. Assy:							Format A4	Satuan mm			
 Politeknik Negeri Cilacap, Jurusan Teknik Mesin Jl. Dr. Soetomo, No. 01, Sidakaya, Cilacap, 53212 Telp: 0282-533329, E-mail: tmpnc@politeknikcilacap.ac.id											
4				3			2		1		

	4	3	2	1
No.	Perubahan	Tanggal	Nama	No.
No.	Perubahan	Tanggal	Nama	No.

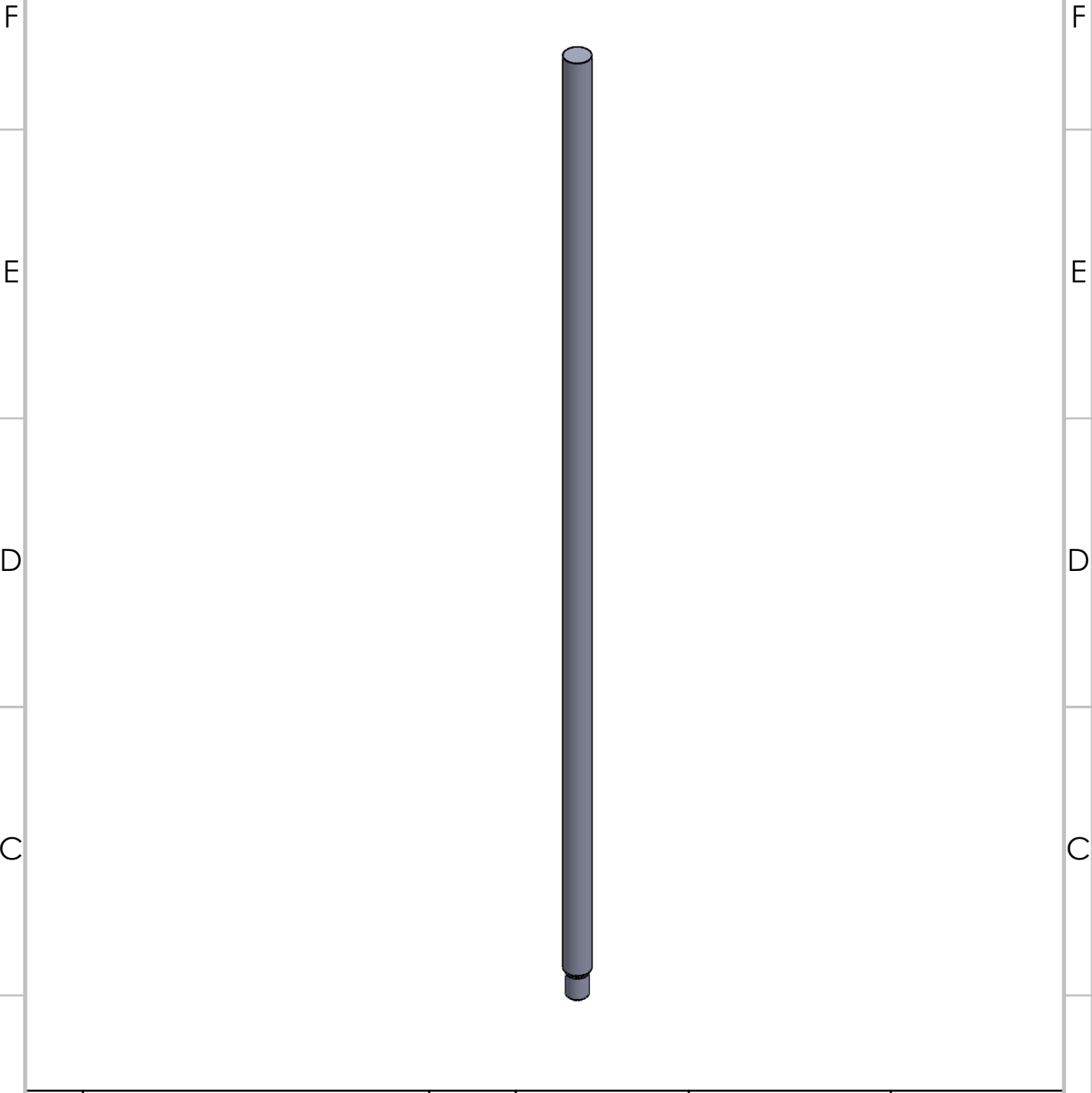

1	Turbine Shaft						F1	S45C	Lihat detail	Dibuat				
B	Jml	Nama Bagian						No.Id	Bahan	Ukuran	Keterangan			
	>	0	6	30	120	400	1000	Ukuran Lanjut:	No. Order:	Proyeksi:				
	<	6	30	120	400	1000	2000							
	Tol	±0.1	±0.2	±0.3	±0.5	±0.8	±1.2							
A	Nama:								Skala	Digambar	1-8-22	Rendi		
	TURBINE SHAFT								1:2	Diperiksa		Radhi		
	No. Assy:									Disahkan		Bayu		
	No. Assy:													
	Politeknik Negeri Cilacap, Jurusan Teknik Mesin Jl. Dr. Soetomo, No. 01, Sidakaya, Cilacap, 53212 Telp: 0282-533329, E-mail: tmpnc@politeknikcilacap.ac.id								Format	Satuan				
									A4	mm				

DILARANG MENGGANDAKAN, MENYALIN, MEMINDAHTANGKAN GAMBAR INI
TANPA IZIN TERTULIS DARI POLITEKNIK NEGERI CILACAP

4		3		2		1	
No.	Perubahan	Tanggal	Nama	No.	Perubahan	Tanggal	Nama
△				△			

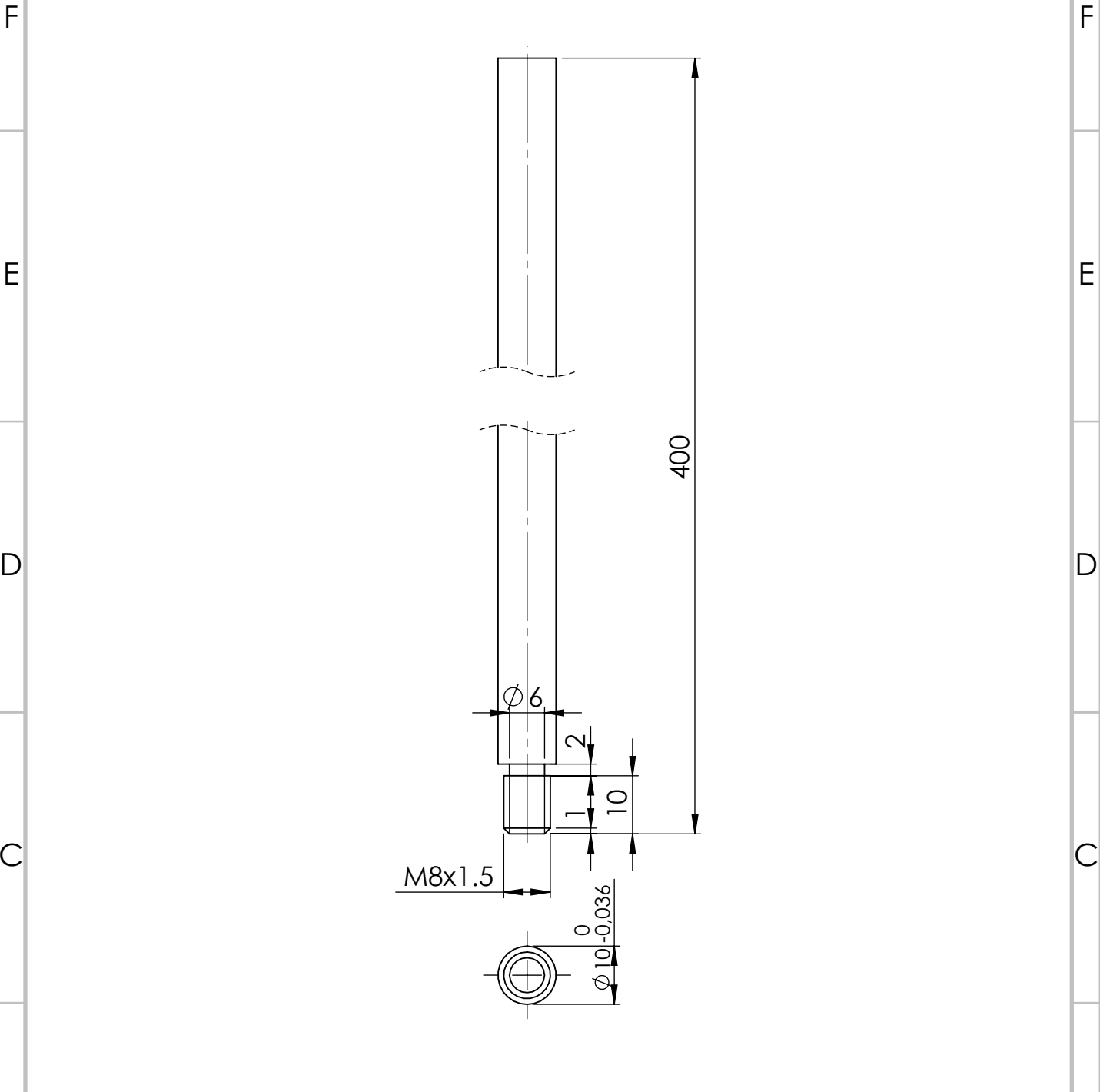

1	Turbine Shaft					F1	S45C	Lihat detail	Dibuat		
B	Jml	Nama Bagian					No.Id	Bahan	Ukuran	Keterangan	
	>	0	6	30	120	400	1000	Ukuran Lanjut:	No. Order:	Proyeksi:	
	<	6	30	120	400	1000	2000				
	Tol	±0.1	±0.2	±0.3	±0.5	±0.8	±1.2				
A	Nama:							Skala 1:1	Digambar	1-8-22	Rendi
	TURBINE SHAFT								Diperiksa		Radhi
									No. Assy:		
	Politeknik Negeri Cilacap, Jurusan Teknik Mesin Jl. Dr. Soetomo, No. 01, Sidakaya, Cilacap, 53212 Telp: 0282-533329, E-mail: tmpnc@politeknikcilacap.ac.id							Format A4			

DILARANG MENGGANDAKAN, MENYALIN, MEMINDAHTANGKAN GAMBAR INI TANPA IZIN TERTULIS DARI POLITEKNIK NEGERI CILACAP

	4	3	2	1
No.	Perubahan	Tanggal	Nama	No.
△				△

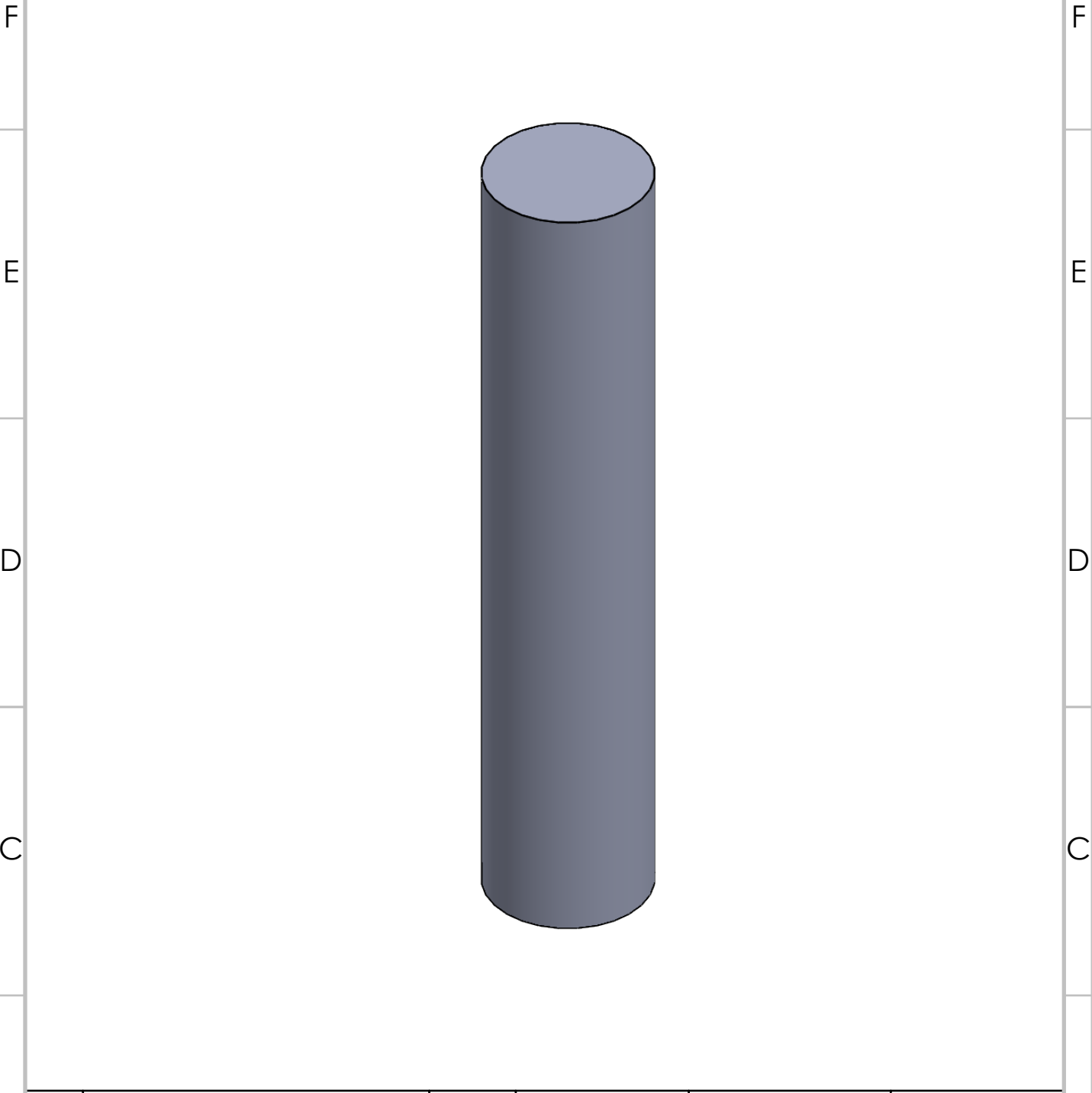

1	Converter Shaft					F2	S45C	Lihat Detail	Dibeli		
B	Jml Nama Bagian					No.Id	Bahan	Ukuran	Keterangan		
	>	0	6	30	120	400	1000	Ukuran Lanjut:	No. Order:	Proyeksi:	
	<	6	30	120	400	1000	2000				
	Tol	±0.1	±0.2	±0.3	±0.5	±0.8	±1.2				
	Nama:							Skala	Digambar	1-8-22	Rendi
	CONVERTER SHAFT							5:1	Diperiksa		Radhi
	No. Assy:								Disahkan		Bayu
A	Politeknik Negeri Cilacap, Jurusan Teknik Mesin Jl. Dr. Soetomo, No. 01, Sidakaya, Cilacap, 53212 Telp: 0282-533329, E-mail: tmpnc@politeknikcilacap.ac.id							Format	Satuan		
								A4	mm		

4	3	2	1
No.	Perubahan	Tanggal	Nama
No.	Perubahan	Tanggal	Nama

F

F

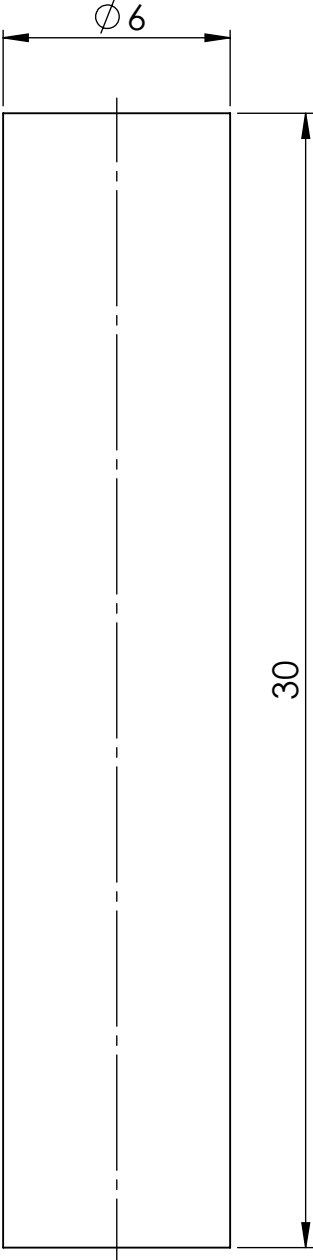

E

E

D

D

C

C

1	Converter Shaft	F2	S45C	Lihat Detail	Dibeli
B	Jml Nama Bagian	No.Id	Bahan	Ukuran	Keterangan
>	0 6 30 120 400 1000	Ukuran Lanjut:		No. Order:	Proyeksi:
<	6 30 120 400 1000 2000				
Tol	±0.1 ±0.2 ±0.3 ±0.5 ±0.8 ±1.2				

A

A

Nama:	5:1	Digambar	1-8-22	Rendi
CONVERTER SHAFT		Diperiksa		Radhi
No. Assy:		Disahkan		Bayu

Politeknik Negeri Cilacap, Jurusan Teknik Mesin Jl. Dr. Soetomo, No. 01, Sidakaya, Cilacap, 53212 Telp: 0282-533329, E-mail: tmpnc@politeknikcilacap.ac.id	Format	Satuan		
	A4	mm		

4			3		2		1
No.	Perubahan	Tanggal	Nama	No.	Perubahan	Tanggal	Nama
△				△			

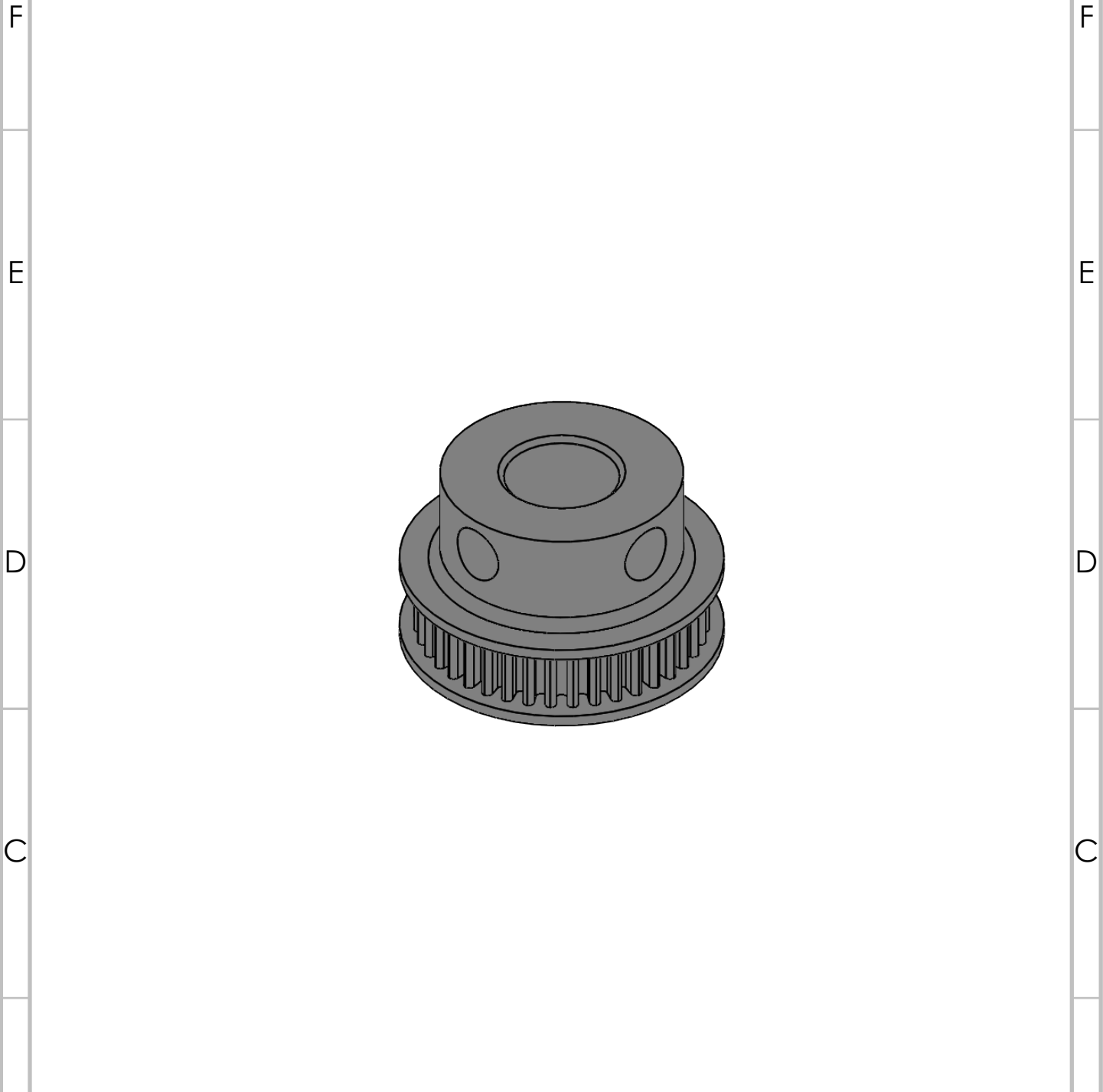

1	Timing Pulley 40T						PL1	Al Alloy	Lihat Detail	Dibeli	
B	Jml		Nama Bagian				No.Id	Bahan	Ukuran	Keterangan	
>	0	6	30	120	400	1000	Ukuran Lanjut:	No. Order:	Proyeksi:		
<	6	30	120	400	1000	2000					
Tol	±0.1	±0.2	±0.3	±0.5	±0.8	±1.2					

A	Nama:							Skala 2:1	Digambar	1-8-22	Rendi
	TIMING PULLEY 40T								Diperiksa		Radhi
									Disahkan		Bayu
No. Assy:											

 Politeknik Negeri Cilacap, Jurusan Teknik Mesin Jl. Dr. Soetomo, No. 01, Sidakaya, Cilacap, 53212 Telp: 0282-533329, E-mail: tmpnc@politeknikcilacap.ac.id							Format A4	Satuan mm		
---	--	--	--	--	--	--	---------------------	---------------------	--	--

DILARANG MENGGANDAKAN, MENYALIN, MEMINDAHKANKAN GAMBAR INI TANPA IZIN TERTULIS DARI POLITEKNIK NEGERI CILACAP

PENGGANTI DARI:

DIGANTI DENGAN

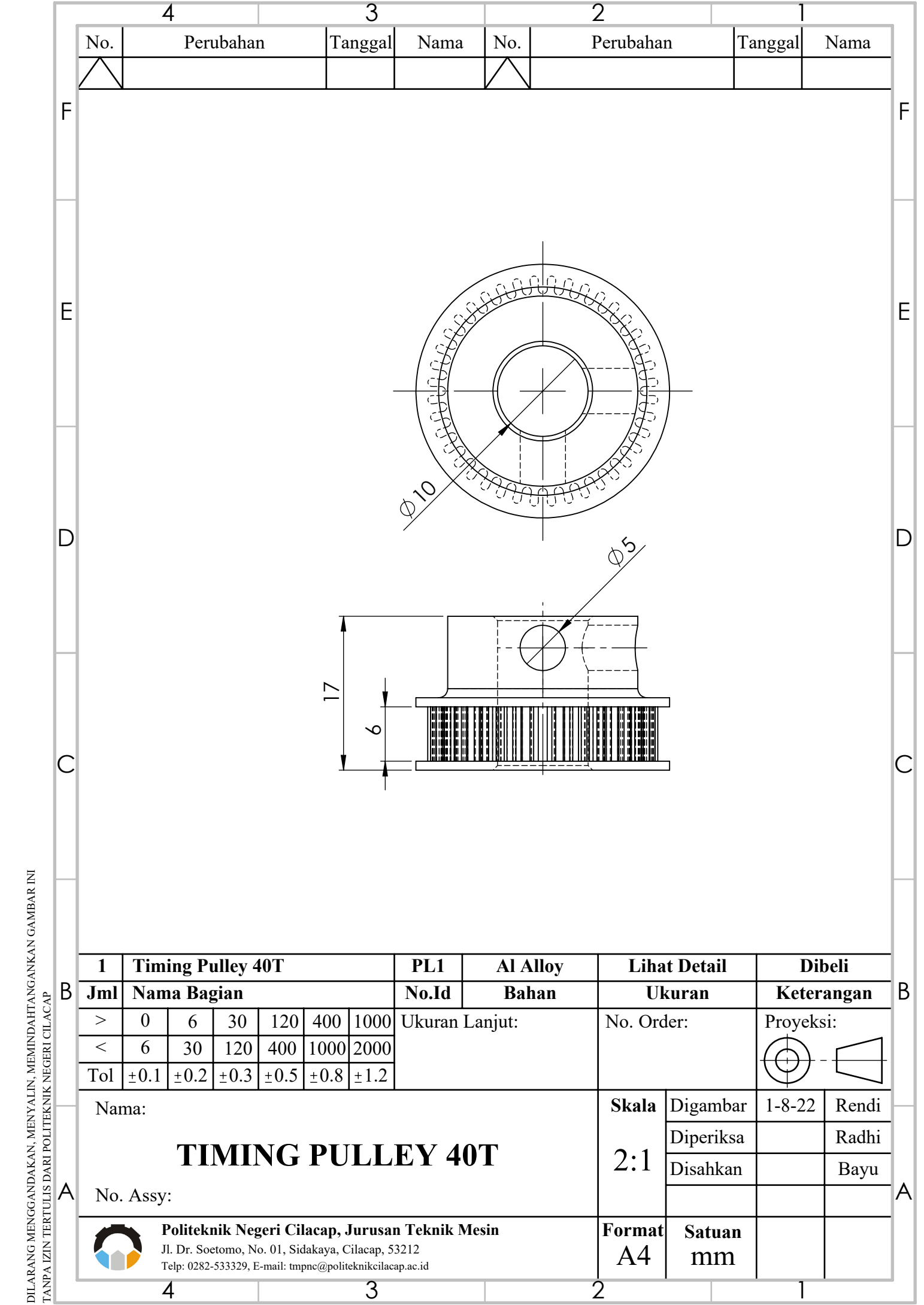

DILARANG MENGGANDAKAN, MENYALIN, MEMINDAH TANGKAPAN GAMBAR INI
 TANPA IZIN TERTULIS DARI POLITEKNIK NEGERI CILACAP

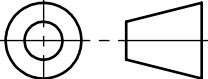
1		Timing Pulley 40T					PL1	Al Alloy	Lihat Detail	Dibeli	
Jml		Nama Bagian					No.Id	Bahan	Ukuran	Keterangan	
>	0	6	30	120	400	1000	Ukuran Lanjut:		No. Order:		
<	6	30	120	400	1000	2000			Proyeksi:		
Tol	±0.1	±0.2	±0.3	±0.5	±0.8	±1.2					

Nama:	TIMING PULLEY 40T	Skala 2:1	Digambar	1-8-22	Rendi
No. Assy:			Diperiksa		Radhi
			Disahkan		Bayu

 Politeknik Negeri Cilacap, Jurusan Teknik Mesin Jl. Dr. Soetomo, No. 01, Sidakaya, Cilacap, 53212 Telp: 0282-533329, E-mail: tmpnc@politeknikcilacap.ac.id	Format A4	Satuan mm	
---	---------------------	---------------------	--

PENGGANTI DARI: DIGANTI DENGAN

DILARANG MENGGANDAKAN, MENYALIN, MEMINDAHKAN GAMBAR INI TANPA IZIN TERTULIS DARI POLITEKNIK NEGERI CILACAP

4		3			2		1
No.	Perubahan	Tanggal	Nama	No.	Perubahan	Tanggal	Nama
△				△			

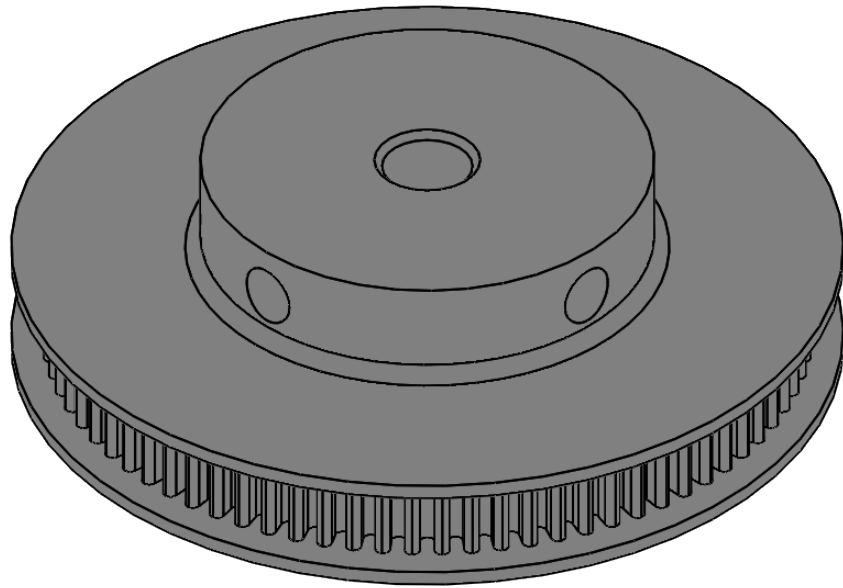

1	Timing Pulley 80T						PL2	Al Alloy	Lihat Detail	Dibeli		
B	Jml		Nama Bagian				No.Id	Bahan	Ukuran	Keterangan		
	>	0	6	30	120	400	1000	Ukuran Lanjut:	No. Order:	Proyeksi:		
	<	6	30	120	400	1000	2000					
	Tol	±0.1	±0.2	±0.3	±0.5	±0.8	±1.2					
Nama:									Skala 2:1	Digambar	1-8-22	Rendi
TIMING PULLEY 80T										Diperiksa		Radhi
										Disahkan		Bayu
No. Assy:												
 Politeknik Negeri Cilacap, Jurusan Teknik Mesin Jl. Dr. Soetomo, No. 01, Sidakaya, Cilacap, 53212 Telp: 0282-533329, E-mail: tmpnc@politeknikcilacap.ac.id									Format A4	Satuan mm		

4		3		2		1	
No.	Perubahan	Tanggal	Nama	No.	Perubahan	Tanggal	Nama
△				△			

F
E
D
C
B
A

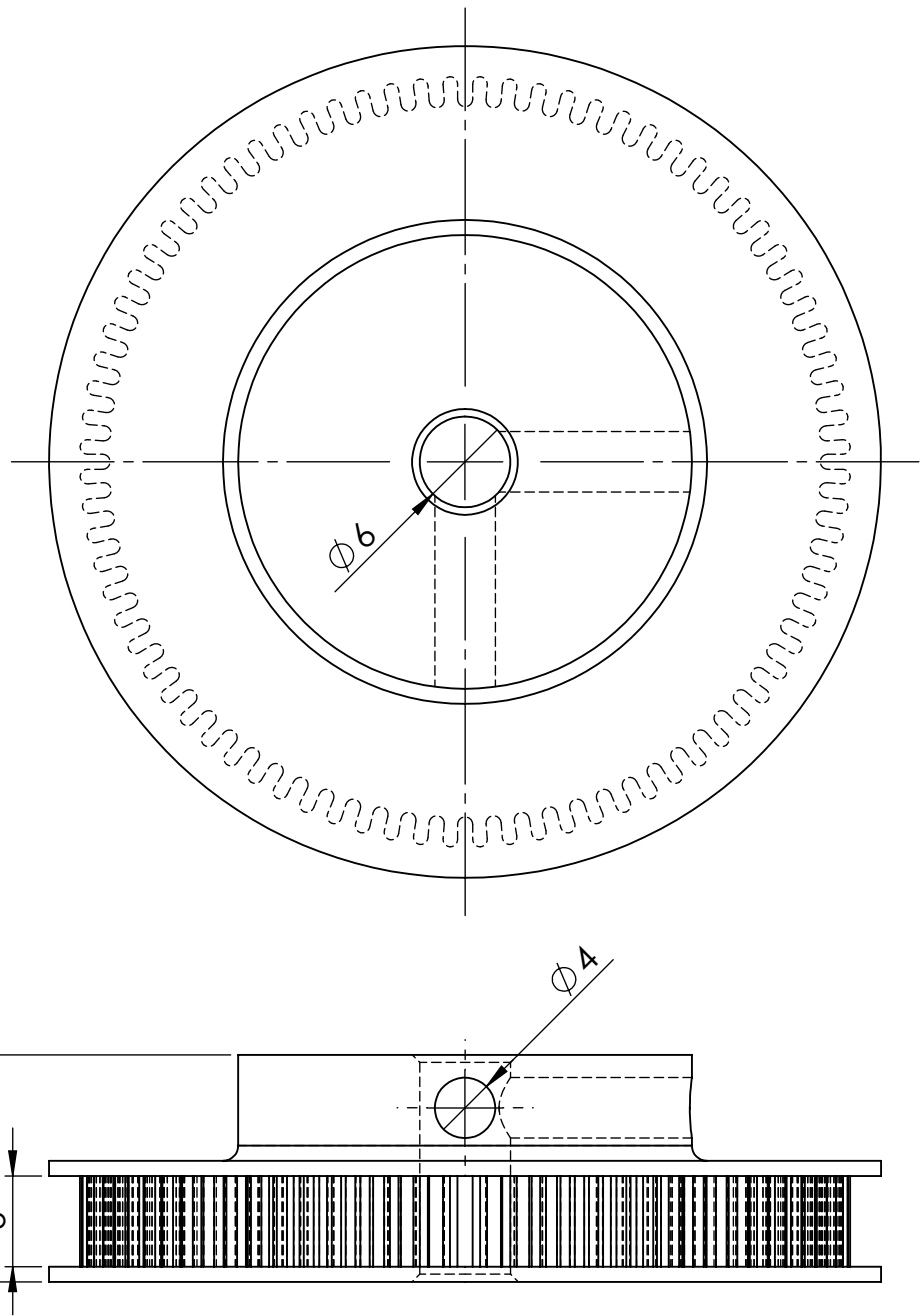

1	Timing Pulley 80T						PL2	Al Alloy	Lihat Detail	Dibeli		
B	Jml Nama Bagian						No.Id	Bahan	Ukuran	Keterangan		
	>	0	6	30	120	400	1000	Ukuran Lanjut:	No. Order:	Proyeksi: 		
	<	6	30	120	400	1000	2000					
	Tol	±0.1	±0.2	±0.3	±0.5	±0.8	±1.2					
Nama:									Skala 2:1	Digambar	1-8-22	Rendi
TIMING PULLEY 80T										Diperiksa		Radhi
										Disahkan		Bayu
No. Assy:									Format A4	Satuan mm		
 Politeknik Negeri Cilacap, Jurusan Teknik Mesin Jl. Dr. Soetomo, No. 01, Sidakaya, Cilacap, 53212 Telp: 0282-533329, E-mail: tmpnc@politeknikcilacap.ac.id												

F
E
D
C
B
A

DILARANG MENGGANDAKAN, MENYALIN, MEMINDAHTANGKAN GAMBAR INI TANPA IZIN TERTULIS DARI POLITEKNIK NEGERI CILACAP