

LAMPIRAN 1

Biodata Penulis

BIODATA PENULIS



Nama : Dian Mei Ashidiq
Tempat/Tanggal Lahir : Cilacap, 01 Mei 2001
Alamat : Dusun Kebanaran Rt 04/Rw 05, Desa
Gandrungmangu, Kecamatan Gandrungmangu,
Kabupaten Cilacap.
Email : Dianmeiashidiq@gmail.com
Telepon/HP : 0895337129660
Hobi : Hiking

Riwayat pendidikan

- Mi Ma'arif 02 Gandrungmangu : Tahun 2007 – 2013
- Mts Negeri Kawunganten : Tahun 2013 – 2016
- SMK Negeri 01 Kawunganten : Tahun 2016 – 2019
- Politeknik Negeri Cilacap : Tahun 2019 – 2024

Penulis telah mengikuti Sidang Tugas Akhir pada tanggal 06 Agustus 2024.
Sebagai salah satu persyaratan untuk memperoleh gelar Ahli Madya (A.Md).

Saya yang bersangkutan

(Dian Mei Ashidiq)

LAMPIRAN 2
Dokumentasi Pengujian Mesin





LAMPIRAN 3

Gambar Detail

	5		4		3		2		1		
NO	PERUBAHAN			TANGGAL	NAMA	NO	PERUBAHAN			TANGGAL	NAMA
						∇					

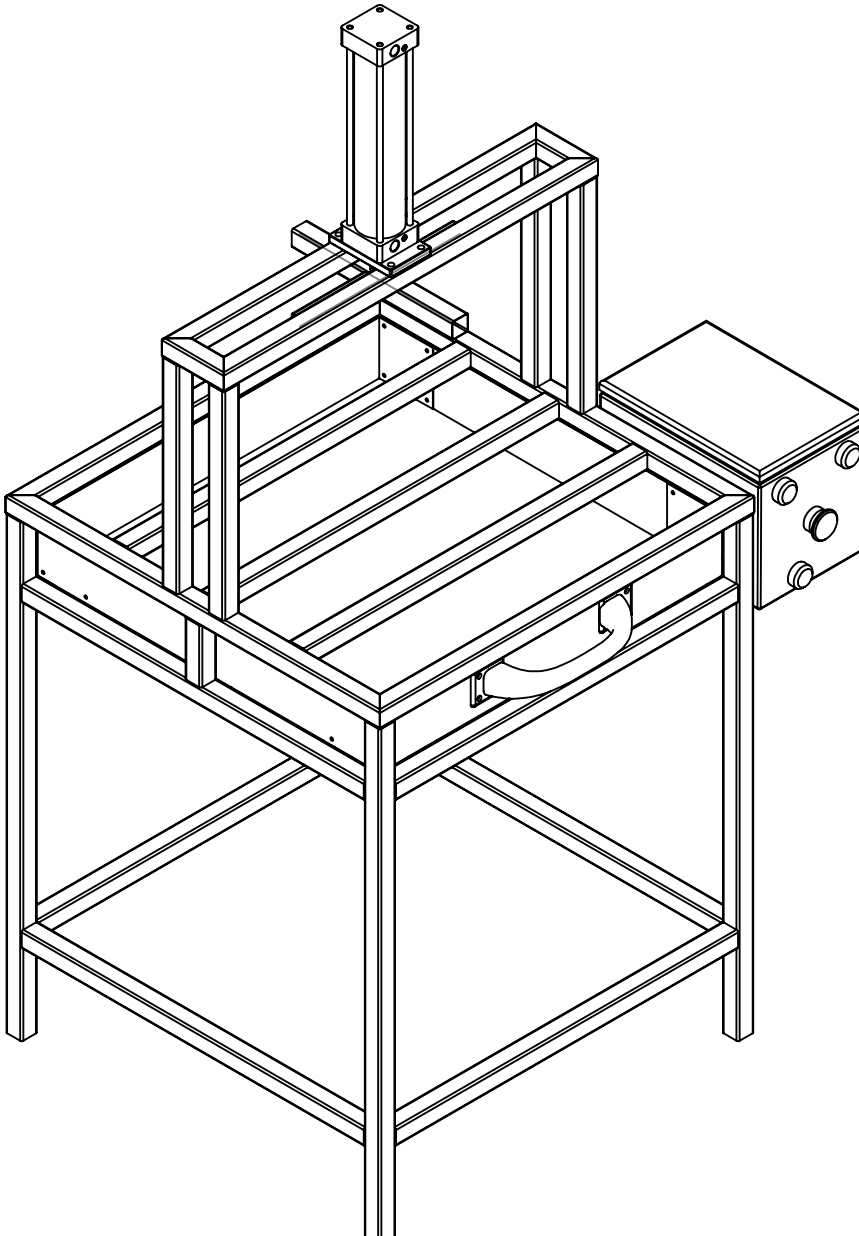

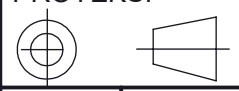
JML	NAMA BAGIAN					POS	BAHAN	UKURAN JADI	UKURAN KASAR	NO. ID	F
>	0	6	30	120	400	1000	UKURAN LANJUT	NO. ORDER	PROYEKSI		
<	6	30	120	400	1000	2000					
TOL	±0.1	±0.2	±0.3	±0.5	±0.8	±1.2					

NAMA : <h2 style="text-align: center; margin: 0;">ASSEMBLY</h2> NO. ASSY. :	<table border="1" style="width:100%; border-collapse: collapse;"> <tr> <td rowspan="3" style="text-align:center; vertical-align: middle;">SKALA 1:10</td> <td style="text-align:center;">DIGAMBAR</td> <td style="text-align:center;">05-13-2024</td> <td style="text-align:center;">DIAN MEI</td> </tr> <tr> <td style="text-align:center;">DIPERIKSA</td> <td> </td> <td> </td> </tr> <tr> <td style="text-align:center;">DISAHKAN</td> <td> </td> <td> </td> </tr> </table> <table border="1" style="width:100%; border-collapse: collapse; margin-top: 5px;"> <tr> <td style="text-align:center;">FORMAT</td> <td style="text-align:center;">SATUAN</td> <td rowspan="2" style="text-align:center; vertical-align: middle;">NO : 18/TM</td> </tr> <tr> <td style="text-align:center;">A4</td> <td style="text-align:center;">mm</td> </tr> </table>	SKALA 1:10	DIGAMBAR	05-13-2024	DIAN MEI	DIPERIKSA			DISAHKAN			FORMAT	SATUAN	NO : 18/TM	A4	mm
SKALA 1:10	DIGAMBAR		05-13-2024	DIAN MEI												
	DIPERIKSA															
	DISAHKAN															
FORMAT	SATUAN	NO : 18/TM														
A4	mm															





	5		4		3		2		1
PERUBAHAN DARI :				DIGANTI DENGAN :					

5		4			3		2		1																																													
NO	PERUBAHAN			TANGGAL	NAMA	NO	PERUBAHAN		TANGGAL	NAMA																																												
						△																																																
<table border="1"> <thead> <tr> <th>JML</th> <th colspan="5">NAMA BAGIAN</th> <th>POS</th> <th>BAHAN</th> <th>UKURAN JADI</th> <th>UKURAN KASAR</th> <th>NO. ID</th> <th>F</th> </tr> </thead> <tbody> <tr> <td>></td> <td>0</td> <td>6</td> <td>30</td> <td>120</td> <td>400</td> <td>1000</td> <td rowspan="3">UKURAN LANJUT</td> <td rowspan="3">NO. ORDER</td> <td colspan="3">PROYEKSI</td> </tr> <tr> <td><</td> <td>6</td> <td>30</td> <td>120</td> <td>400</td> <td>1000</td> <td>2000</td> <td colspan="3"> </td> </tr> <tr> <td>TOL</td> <td>±0.1</td> <td>±0.2</td> <td>±0.3</td> <td>±0.5</td> <td>±0.8</td> <td>±1.2</td> <td colspan="3"></td> </tr> </tbody> </table>											JML	NAMA BAGIAN					POS	BAHAN	UKURAN JADI	UKURAN KASAR	NO. ID	F	>	0	6	30	120	400	1000	UKURAN LANJUT	NO. ORDER	PROYEKSI			<	6	30	120	400	1000	2000				TOL	±0.1	±0.2	±0.3	±0.5	±0.8	±1.2			
JML	NAMA BAGIAN					POS	BAHAN	UKURAN JADI	UKURAN KASAR	NO. ID	F																																											
>	0	6	30	120	400	1000	UKURAN LANJUT	NO. ORDER	PROYEKSI																																													
<	6	30	120	400	1000	2000																																																
TOL	±0.1	±0.2	±0.3	±0.5	±0.8	±1.2																																																
NAMA : <h2 style="text-align: center;">BRACKET CYLINDER</h2>								SKALA 1:10		DIGAMBAR 05-13-2024 DIAN MEI	DIPERIKSA 	DISAHKAN 																																										
NO. ASSY. :								FORMAT A4		SATUAN mm	NO : 18/TM																																											
POLITEKNIK NEGERI CILACAP, JURUSAN TEKNIK MESIN JL. dr. SOETOMO, NO. 01, SIDAKAYA, CILACAP, 53212 TELP : 0282 - 533329, E-mail :tmpnc@politeknikcilacap.ac.id																																																						

PERUBAHAN DARI :

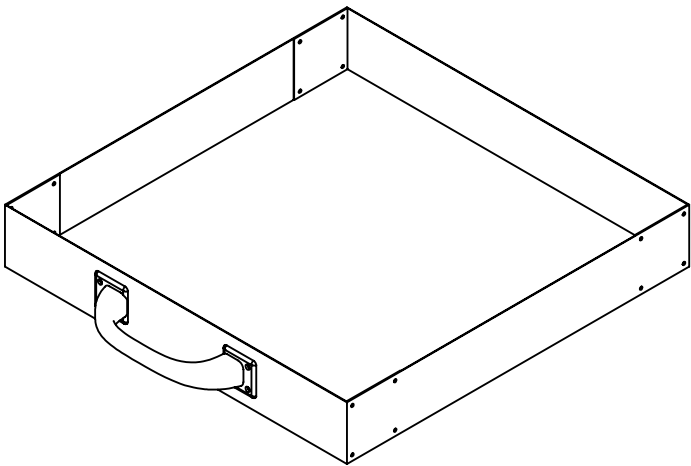
DIGANTI DENGAN :

5		4			3		2		1																																								
NO	PERUBAHAN			TANGGAL	NAMA	NO	PERUBAHAN		TANGGAL	NAMA																																							
						△																																											
<table border="1"> <thead> <tr> <th>JML</th> <th colspan="5">NAMA BAGIAN</th> <th>POS</th> <th>BAHAN</th> <th>UKURAN JADI</th> <th>UKURAN KASAR</th> <th>NO. ID</th> <th>F</th> </tr> </thead> <tbody> <tr> <td>></td> <td>0</td> <td>6</td> <td>30</td> <td>120</td> <td>400</td> <td>1000</td> <td rowspan="3">UKURAN LANJUT</td> <td rowspan="3">NO. ORDER</td> <td colspan="3">PROYEKSI</td> </tr> <tr> <td><</td> <td>6</td> <td>30</td> <td>120</td> <td>400</td> <td>1000</td> <td>2000</td> <td> </td> </tr> <tr> <td>TOL</td> <td>±0.1</td> <td>±0.2</td> <td>±0.3</td> <td>±0.5</td> <td>±0.8</td> <td>±1.2</td> </tr> </tbody> </table>											JML	NAMA BAGIAN					POS	BAHAN	UKURAN JADI	UKURAN KASAR	NO. ID	F	>	0	6	30	120	400	1000	UKURAN LANJUT	NO. ORDER	PROYEKSI			<	6	30	120	400	1000	2000		TOL	±0.1	±0.2	±0.3	±0.5	±0.8	±1.2
JML	NAMA BAGIAN					POS	BAHAN	UKURAN JADI	UKURAN KASAR	NO. ID	F																																						
>	0	6	30	120	400	1000	UKURAN LANJUT	NO. ORDER	PROYEKSI																																								
<	6	30	120	400	1000	2000																																											
TOL	±0.1	±0.2	±0.3	±0.5	±0.8	±1.2																																											
NAMA : <h1 style="text-align: center;">RANGKA</h1>								SKALA 1:20		DIGAMBAR 05-13-2024 DIPERIKSA DISAHKAN	DIAN MEI																																						
NO. ASSY. :								FORMAT A4	SATUAN mm	NO : 18/TM																																							
POLITEKNIK NEGERI CILACAP, JURUSAN TEKNIK MESIN JL. dr. SOETOMO, NO. 01, SIDAKAYA, CILACAP, 53212 TELP : 0282 - 533329, E-mail :tmpnc@politeknikcilacap.ac.id								FORMAT A4	SATUAN mm	NO : 18/TM																																							
5		4			3		2		1																																								
PERUBAHAN DARI :					DIGANTI DENGAN :																																												

5		4			3		2		1																																								
NO	PERUBAHAN	TANGGAL	NAMA	NO	PERUBAHAN	TANGGAL	NAMA																																										
				/																																													
																																																	
<table border="1" style="width:100%; border-collapse: collapse;"> <tr> <td style="width: 5%;">JML</td> <td colspan="5" style="width: 45%;">NAMA BAGIAN</td> <td style="width: 5%;">POS</td> <td style="width: 10%;">BAHAN</td> <td style="width: 15%;">UKURAN JADI</td> <td style="width: 15%;">UKURAN KASAR</td> <td style="width: 10%;">NO. ID</td> <td style="width: 5%;">F</td> </tr> <tr> <td style="text-align: center;">></td> <td style="text-align: center;">0</td> <td style="text-align: center;">6</td> <td style="text-align: center;">30</td> <td style="text-align: center;">120</td> <td style="text-align: center;">400</td> <td style="text-align: center;">1000</td> <td rowspan="3" style="text-align: center;">UKURAN LANJUT</td> <td rowspan="3" style="text-align: center;">NO. ORDER</td> <td colspan="3" style="text-align: center;">PROYEKSI</td> </tr> <tr> <td style="text-align: center;"><</td> <td style="text-align: center;">6</td> <td style="text-align: center;">30</td> <td style="text-align: center;">120</td> <td style="text-align: center;">400</td> <td style="text-align: center;">1000</td> <td style="text-align: center;">2000</td> <td style="text-align: center;">  </td> </tr> <tr> <td style="text-align: center;">TOL</td> <td style="text-align: center;">±0.1</td> <td style="text-align: center;">±0.2</td> <td style="text-align: center;">±0.3</td> <td style="text-align: center;">±0.5</td> <td style="text-align: center;">±0.8</td> <td style="text-align: center;">±1.2</td> </tr> </table>											JML	NAMA BAGIAN					POS	BAHAN	UKURAN JADI	UKURAN KASAR	NO. ID	F	>	0	6	30	120	400	1000	UKURAN LANJUT	NO. ORDER	PROYEKSI			<	6	30	120	400	1000	2000		TOL	±0.1	±0.2	±0.3	±0.5	±0.8	±1.2
JML	NAMA BAGIAN					POS	BAHAN	UKURAN JADI	UKURAN KASAR	NO. ID	F																																						
>	0	6	30	120	400	1000	UKURAN LANJUT	NO. ORDER	PROYEKSI																																								
<	6	30	120	400	1000	2000																																											
TOL	±0.1	±0.2	±0.3	±0.5	±0.8	±1.2																																											
<p>NAMA :</p> <h1 style="margin: 0;">PENAMPUNG AIR</h1> <p>NO. ASSY. :</p>								SKALA 1:10	DIGAMBAR 05-13-2024 DIAN MEI DIPERIKSA DISAHKAN	NO. ID NO. ID NO. ID	F F F																																						
 POLITEKNIK NEGERI CILACAP, JURUSAN TEKNIK MESIN JL. dr. SOETOMO, NO. 01, SIDAKAYA, CILACAP, 53212 TELP : 0282 - 533329, E-mail :tmpnc@politeknikcilacap.ac.id								FORMAT A4	SATUAN mm	NO : 18/TM																																							
5		4			3		2		1																																								

PERUBAHAN DARI :

DIGANTI DENGAN :

5	4	3	2	1			
NO	PERUBAHAN	TANGGAL	NAMA	NO	PERUBAHAN	TANGGAL	NAMA
				/			

639

640

32

182

10

80

Ø5

10

80

JML	NAMA BAGIAN					POS	BAHAN	UKURAN JADI	UKURAN KASAR	NO. ID	F
>	0	6	30	120	400	1000	UKURAN LANJUT	NO. ORDER	PROYEKSI		
<	6	30	120	400	1000	2000					
TOL	±0.1	±0.2	±0.3	±0.5	±0.8	±1.2					

NAMA : <h2 style="text-align: center;">PENAMPUNG AIR</h2>	SKALA <h3 style="text-align: center;">1:10</h3>	DIGAMBAR 05-13-2024 DIAN MEI	DIPERIKSA DISAHKAN	NO. ID NO : 18/TM
NO. ASSY. :	FORMAT <h3 style="text-align: center;">A4</h3>	SATUAN mm		

5	4	3	2	1
PERUBAHAN DARI :			DIGANTI DENGAN :	