

LAMPIRAN 1
PROSES PRODUKSI





LAMPIRAN 2

PROSES PENGUJIAN



LAMPIRAN 3 FORM SARAN DAN MASUKAN

LAMPIRAN 3 FORM SARAN DAN MASUKAN



SARAN :

1. Penambahan alat bantu pembuka pengunci ampelas dengan mur yang dilas ke pengunci ampelas kemudian baut yang dilas T untuk sebagai membantu menarik pengunci
2. Penambahan pelindung komponen bagian kelistrikan untuk mencegah terjadinya air terkena komponen kelistrikan
3. Memberikan keterangan tentang tombol-tombol
4. Penambahan *sealer* pada bagian pinggir tombol-tombol
5. Penambahan cover bagian bawah seperti di pompa yang berhubungan dengan air supaya untuk mencegah terjadi konsleting listrik
6. Cek ketika magnet kontak langsung dengan air terlalu lama berakibat atau tidak dengan kelistrikan

Cilacap, 25 juli 2024

Narasumber

Dwi Gustoro, A.Md

LAMPIRAN 4

BIODATA PENULIS



A. DATA PRIBADI

Nama	: Billy Oktavian
Tempat, Tanggal Lahir	: Cilacap, 02-10-2001
Jenis kelamin	: Laki-laki
Alamat	: Jalan Sirkaya No 20
RT/RW	: 006/003
Kel/Desa	: Menganti
Kecamatan	: Kesugihan
Agama	: Islam
Email	: billyoktavian25@gmail.com
Telp	: 0878-3447-5747
Hobi	: Sepak bola, futsal dan otomotif
Motto	: Tiap lelah pasti ada berkah, tiap cobaan pasti ada jalan keluar, jangan berhenti untuk berjuang, lengkapi dengan doa semoga impian segera jadi kenyataan.

B. RIWAYAT PENDIDIKAN

- SD Negeri Menganti 01 : Tahun 2008 - 2014
- SMP Negeri 07 Cilacap : Tahun 2014 - 2017
- SMK Dr. Soetomo Cilacap : Tahun 2017 – 2020
- Politeknik Negeri Cilacap : Tahun 2020 – 2024

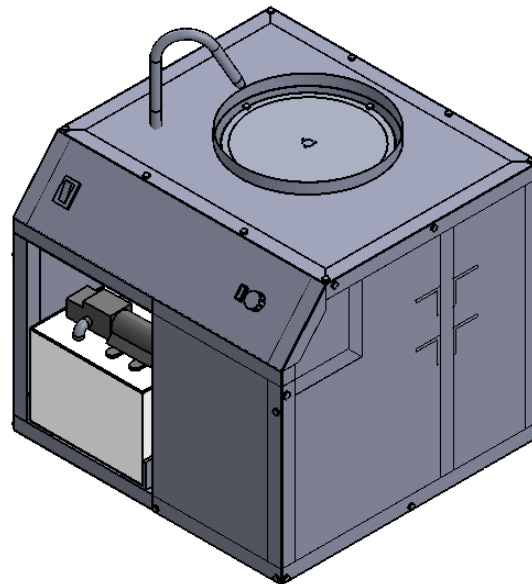

JML	NAMA BAGIAN						POS	BAHAN	UKURAN JADI	UKURAN KASAR	NO. ID	F
>	0	6	30	120	400	1000	PEKERJAAN LANJUT		NO ORDER			
<	6	30	120	400	1000	2000						
TOL	± 0,1	± 0,2	± 0,3	± 0,5	± 0,8	± 1,2						
NAMA :									SKALA	DIGAMBAR	11/6/24	BILLY
MESIN <i>POLISH SINGLE DISC</i>									1 : 10	DIPERIKSA		
										DISAHKAN		
NO. ASSY :									FORMAT	SATUAN	NO GAMBAR	
POLITEKNIK NEGERI CILACAP, JURUSAN TEKNIK MESIN JL. dr. SOETOMO, NO. 01, SIDAKAYA, CILACAP, 53212 TELP : 0282-533329, E-mail : jtm@pnc.ac.id									A4	mm	PSD-01	

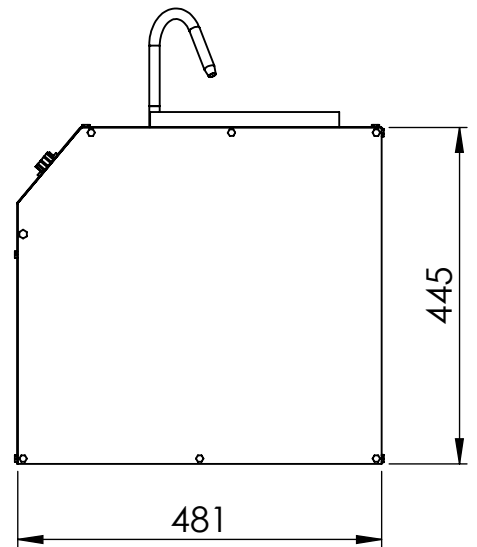
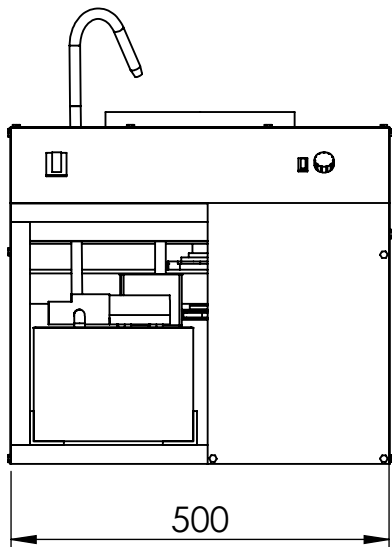
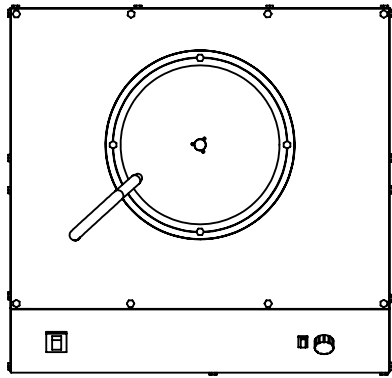

JML	NAMA BAGIAN						POS	BAHAN	UKURAN JADI	UKURAN KASAR	NO. ID	F
>	0	6	30	120	400	1000	PEKERJAAN LANJUT		NO ORDER			
<	6	30	120	400	1000	2000						
TOL	± 0,1	± 0,2	± 0,3	± 0,5	± 0,8	± 1,2						
NAMA :									SKALA	DIGAMBAR	12/6/24	BILLY
MESIN POLISH SINGLE DISC									1 : 10	DIPERIKSA		
										DISAHKAN		
NO. ASSY :									FORMAT	SATUAN	NO GAMBAR	
POLITEKNIK NEGERI CILACAP, JURUSAN TEKNIK MESIN JL. dr. SOETOMO, NO. 01, SIDAKAYA, CILACAP, 53212 TELP : 0282-533329, E-mail : jtm@pnc.ac.id									A4	mm	PSD 02	

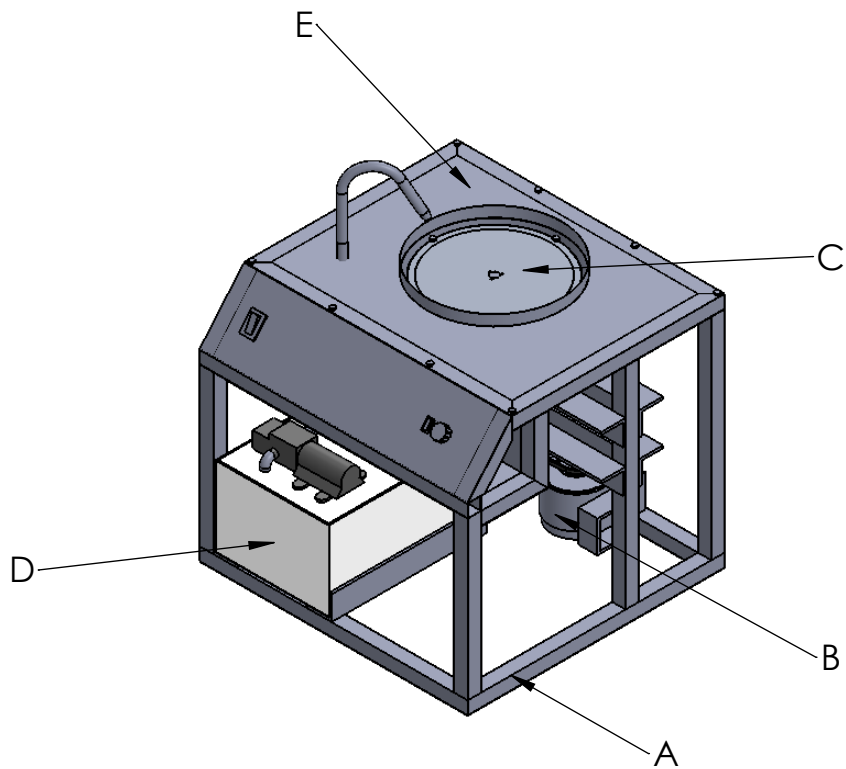

3	Cover		Plat	Lihat detail		E						
1	Box air		Plastik	Lihat detail		D						
1	Piringan		Alumunium	Lihat detail		C						
1	Transmisi			Lihat detail		B						
1	Rangka		Hollow	Lihat detail		A						
JML	NAMA BAGIAN						POS	BAHAN	UKURAN JADI	UKURAN KASAR	NO. ID	F
>	0	6	30	120	400	1000	PEKERJAAN LANJUT		NO ORDER			
<	6	30	120	400	1000	2000						
TOL	± 0,1	± 0,2	± 0,3	± 0,5	± 0,8	± 1,2						

NAMA :

MESIN POLISH SINGLE DISC

SKALA 1 : 10	DIGAMBAR	12/6/24	BILLY
	DIPERIKSA		
	DISAHKAN		

NO. ASSY :



POLITEKNIK NEGERI CILACAP, JURUSAN TEKNIK MESIN
 JL. dr. SOETOMO, NO. 01, SIDAKAYA, CILACAP, 53212
 TELP : 0282-533329, E-mail : jtm@pnc.ac.id

FORMAT A4	SATUAN mm	NO GAMBAR PSD 03
--------------	--------------	---------------------

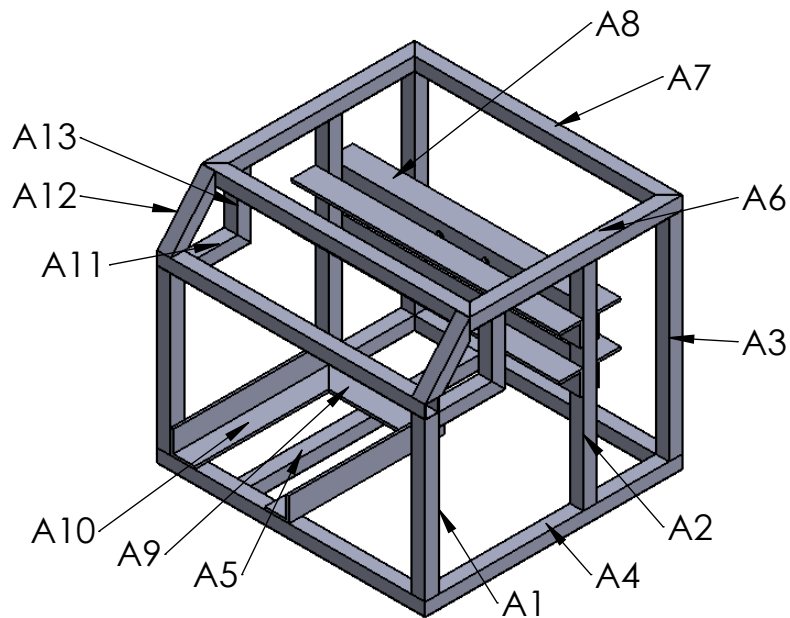

2	Rangka Tinggi Dudukan Kontroler		Hollow Galvanis	Lihat Detail		A13					
2	Rangka Miring		Hollow Galvanis	Lihat Detail		A12					
2	Rangka Lebar Dudukan kontroler		Hollow Galvanis	Lihat Detail		A11					
2	Rangka Lebar Dudukan Box Air		Mildsteel	Lihat Detail		A10					
1	Rangka Panjang Dudukan Box Air		Mildsteel	Lihat Detail		A9					
4	Rangka Dudukan Bantalan		Mildsteel	Lihat Detail		A8					
5	Rangka Panjang		Hollow Galvanis	Lihat Detail		A7					
2	Rangka Lebar Atas		Hollow Galvanis	Lihat Detail		A6					
1	Rangka Lebar Tengah		Hollow Galvanis	Lihat Detail		A5					
2	Rangka Lebar Bawah		Hollow Galvanis	Lihat Detail		A4					
2	Rangka Tinggi belakang		Hollow Galvanis	Lihat Detail		A3					
2	Rangka Tinggi Tengah		Hollow Galvanis	Lihat Detail		A2					
2	Rangka Tinggi Depan		Hollow Galvanis	Lihat Detail		A1					
JML	NAMA BAGIAN					POS	BAHAN	UKURAN JADI	UKURAN KASAR	NO. ID	F
>	0	6	30	120	400	1000	PEKERJAAN LANJUT	NO ORDER			
<	6	30	120	400	1000	2000					
TOL	± 0,1	± 0,2	± 0,3	± 0,5	± 0,8	± 1,2					
NAMA :								SKALA	DIGAMBAR	13/6/24	BILLY
RANGKA								1 : 10	DIPERIKSA		
									DISAHKAN		
NO. ASSY :											
POLITEKNIK NEGERI CILACAP, JURUSAN TEKNIK MESIN JL. dr. SOETOMO, NO. 01, SIDAKAYA, CILACAP, 53212 TELP : 0282-533329, E-mail : jtm@pnc.ac.id								FORMAT A4	SATUAN mm	NO GAMBAR PSD 04	

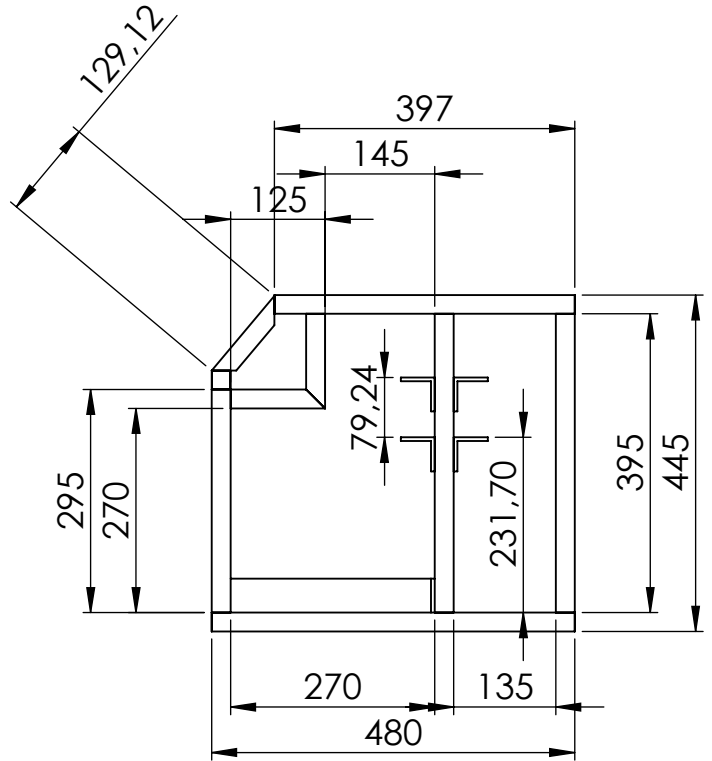
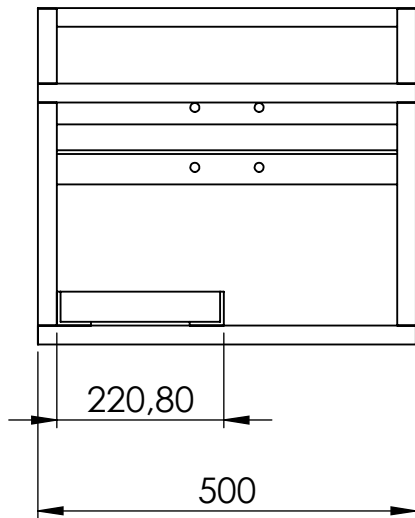

1	Rangka						Hollow galvanis	Lihat detail				
JML	NAMA BAGIAN						POS	BAHAN	UKURAN JADI	UKURAN KASAR	NO. ID F	
>	0	6	30	120	400	1000	PEKERJAAN LANJUT		NO ORDER			
<	6	30	120	400	1000	2000						
TOL	± 0,1	± 0,2	± 0,3	± 0,5	± 0,8	± 1,2						
NAMA :									SKALA	DIGAMBAR	13/6/24	BILLY
RANGKA									1 : 10	DIPERIKSA		
										DISAHKAN		
NO. ASSY :									FORMAT	SATUAN	NO GAMBAR	
POLITEKNIK NEGERI CILACAP, JURUSAN TEKNIK MESIN JL. dr. SOETOMO, NO. 01, SIDAKAYA, CILACAP, 53212 TELP : 0282-533329, E-mail : jtm@pnc.ac.id									A4	mm	PSD 05	

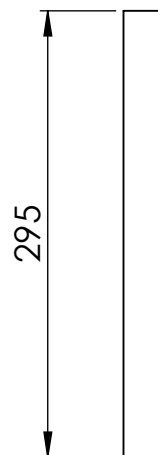
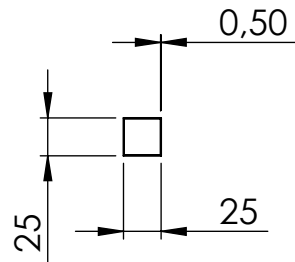

2	Rangka Tinggi Depan						Hollow Galvanis	Lihat Detail		A1		
JML	NAMA BAGIAN						POS	BAHAN	UKURAN JADI	UKURAN KASAR	NO. ID	F
>	0	6	30	120	400	1000	PEKERJAAN LANJUT		NO ORDER			
<	6	30	120	400	1000	2000						
TOL	± 0,1	± 0,2	± 0,3	± 0,5	± 0,8	± 1,2						
NAMA :								SKALA	DIGAMBAR	14/6/24	BILLY	
RANGKA TINGGI DEPAN								1 : 5	DIPERIKSA			
									DISAHKAN			
NO. ASSY :								FORMAT	SATUAN	NO GAMBAR		
POLITEKNIK NEGERI CILACAP, JURUSAN TEKNIK MESIN JL. dr. SOETOMO, NO. 01, SIDAKAYA, CILACAP, 53212 TELP : 0282-533329, E-mail : jtm@pnc.ac.id								A4	mm	PSD 06		

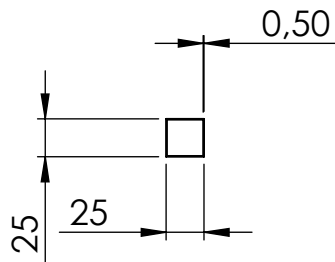

2	Rangka Tinggi Tengah						Hollow Galvanis	Lihat Detail		A2	
JML	NAMA BAGIAN						POS	BAHAN	UKURAN JADI	UKURAN KASAR	NO. ID F
>	0	6	30	120	400	1000	PEKERJAAN LANJUT		NO ORDER		
<	6	30	120	400	1000	2000					
TOL	± 0,1	± 0,2	± 0,3	± 0,5	± 0,8	± 1,2					
NAMA :								SKALA	DIGAMBAR	14/6/24	BILLY
RANGKA TINGGI TENGAH DAN BELAKANG								1 : 5	DIPERIKSA		
									DISAHKAN		
NO. ASSY :								FORMAT	SATUAN	NO GAMBAR	
POLITEKNIK NEGERI CILACAP, JURUSAN TEKNIK MESIN JL. dr. SOETOMO, NO. 01, SIDAKAYA, CILACAP, 53212 TELP : 0282-533329, E-mail : jtm@pnc.ac.id								A4	mm	PSD 07	

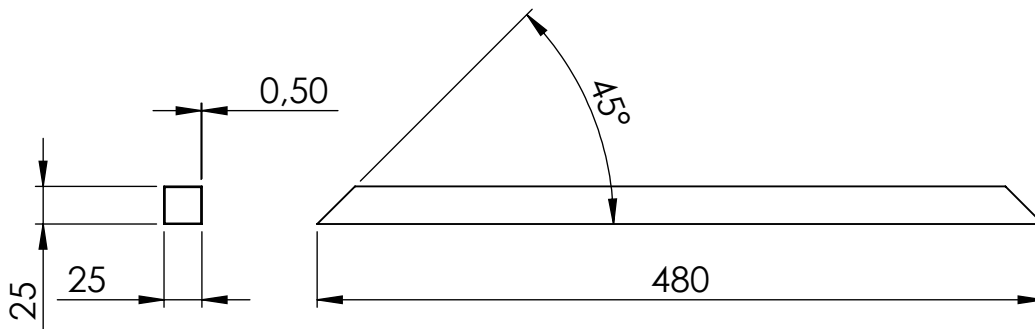
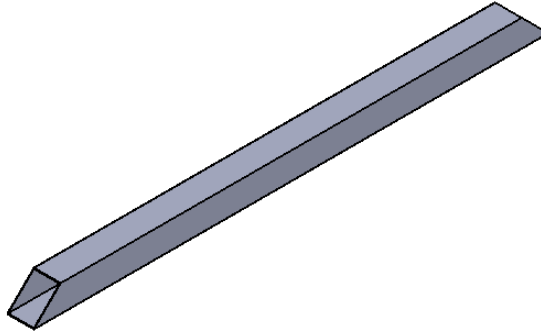

2	Rangka Lebar Bawah						Hollow Galvanis	Lihat Detail		A4	
JML	NAMA BAGIAN						POS	BAHAN	UKURAN JADI	UKURAN KASAR	NO. ID F
>	0	6	30	120	400	1000	PEKERJAAN LANJUT	NO ORDER			
<	6	30	120	400	1000	2000					
TOL	± 0,1	± 0,2	± 0,3	± 0,5	± 0,8	± 1,2					
NAMA :								SKALA	DIGAMBAR	14/6/24	BILLY
RANGKA LEBAR BAWAH								1 : 5	DIPERIKSA		
									DISAHKAN		
NO. ASSY :								FORMAT	SATUAN	NO GAMBAR	
POLITEKNIK NEGERI CILACAP, JURUSAN TEKNIK MESIN JL. dr. SOETOMO, NO. 01, SIDAKAYA, CILACAP, 53212 TELP : 0282-533329, E-mail : jtm@pnc.ac.id								A4	mm	PSD 08	

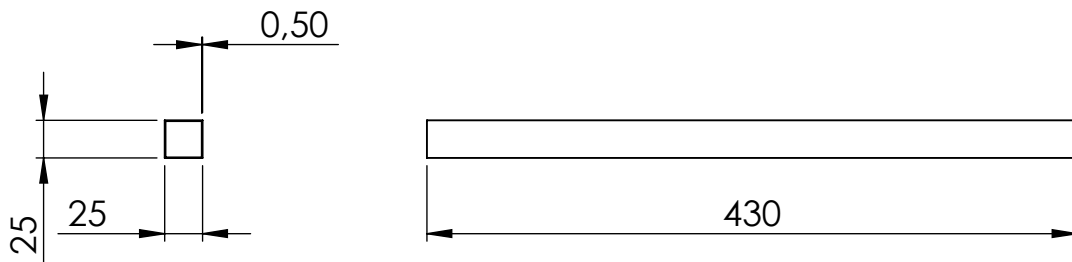
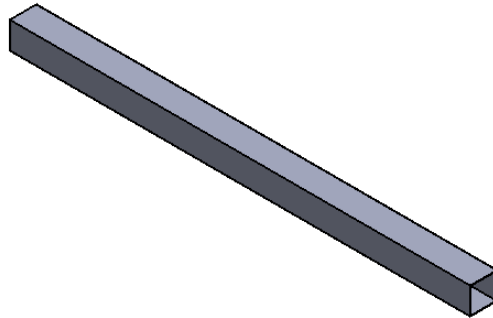

1	Rangka Tengah Bawah						Hollow Galvanis	Lihat Detail			A5	
JML	NAMA BAGIAN						POS	BAHAN	UKURAN JADI	UKURAN KASAR	NO. ID F	
>	0	6	30	120	400	1000	PEKERJAAN LANJUT		NO ORDER			
<	6	30	120	400	1000	2000						
TOL	± 0,1	± 0,2	± 0,3	± 0,5	± 0,8	± 1,2						
NAMA :									SKALA	DIGAMBAR	14/6/24	BILLY
RANGKA TENGAH BAWAH									1 : 5	DIPERIKSA		
										DISAHKAN		
NO. ASSY :									FORMAT	SATUAN	NO GAMBAR	
POLITEKNIK NEGERI CILACAP, JURUSAN TEKNIK MESIN JL. dr. SOETOMO, NO. 01, SIDAKAYA, CILACAP, 53212 TELP : 0282-533329, E-mail : jtm@pnc.ac.id									A4	mm	PSD 09	

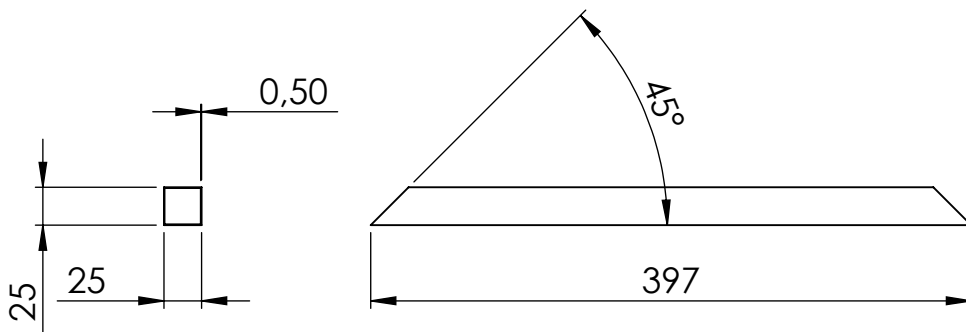
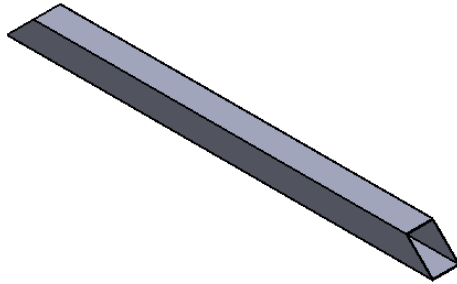

2	Rangka Lebar Atas						Hollow Galvanis	Lihat Detail		A6	
JML	NAMA BAGIAN						POS	BAHAN	UKURAN JADI	UKURAN KASAR	NO. ID F
>	0	6	30	120	400	1000	PEKERJAAN LANJUT		NO ORDER		
<	6	30	120	400	1000	2000					
TOL	± 0,1	± 0,2	± 0,3	± 0,5	± 0,8	± 1,2					
NAMA :								SKALA	DIGAMBAR	19/6/24	BILLY
RANGKA LEBAR ATAS								1 : 5	DIPERIKSA		
									DISAHKAN		
NO. ASSY :								FORMAT	SATUAN	NO GAMBAR	
POLITEKNIK NEGERI CILACAP, JURUSAN TEKNIK MESIN JL. dr. SOETOMO, NO. 01, SIDAKAYA, CILACAP, 53212 TELP : 0282-533329, E-mail : jtm@pnc.ac.id								A4	mm	PSD 10	

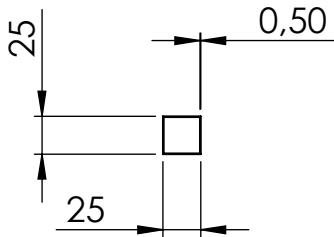
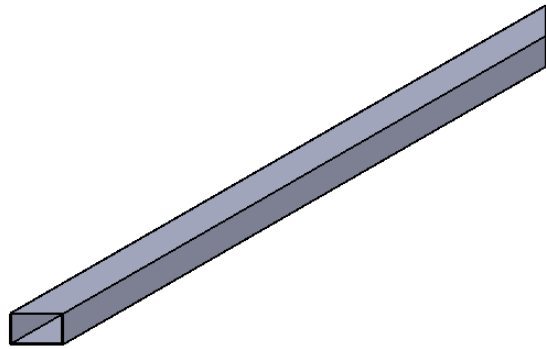
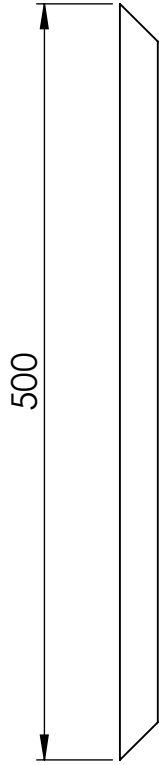

5	Rangka Panjang						Hollow Galvanis	Lihat Detail		A7		
JML	NAMA BAGIAN						POS	BAHAN	UKURAN JADI	UKURAN KASAR	NO. ID	F
>	0	6	30	120	400	1000	PEKERJAAN LANJUT		NO ORDER			
<	6	30	120	400	1000	2000						
TOL	± 0,1	± 0,2	± 0,3	± 0,5	± 0,8	± 1,2						
NAMA :									SKALA	DIGAMBAR	19/6/24	BILLY
RANGKA PANJANG									1 : 5	DIPERIKSA		
										DISAHKAN		
NO. ASSY :									FORMAT	SATUAN	NO GAMBAR	
POLITEKNIK NEGERI CILACAP, JURUSAN TEKNIK MESIN JL. dr. SOETOMO, NO. 01, SIDAKAYA, CILACAP, 53212 TELP : 0282-533329, E-mail : jtm@pnc.ac.id									A4	mm	PSD 11	

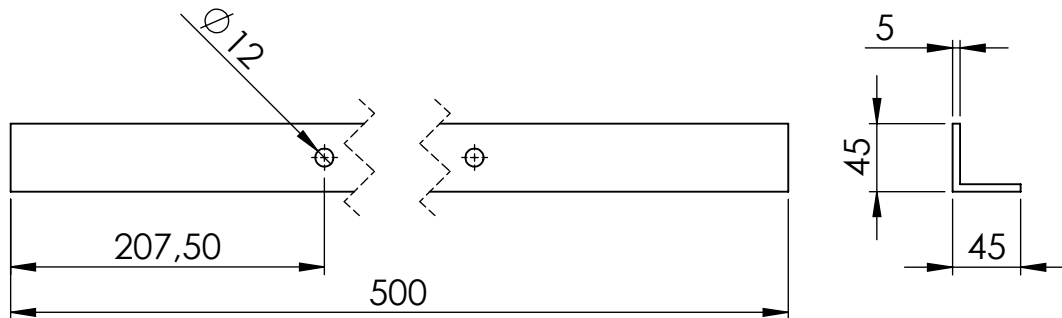
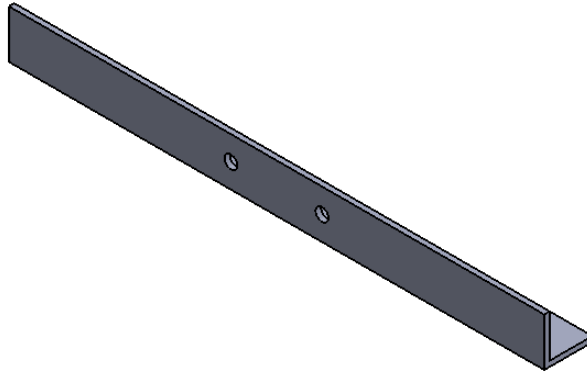

4	Rangka Dudukan Bantalan						Mildsteel	Lihat Detail	A8			
JML	NAMA BAGIAN						POS	BAHAN	UKURAN JADI	UKURAN KASAR	NO. ID	F
>	0	6	30	120	400	1000	PEKERJAAN LANJUT		NO ORDER			
<	6	30	120	400	1000	2000						
TOL	± 0,1	± 0,2	± 0,3	± 0,5	± 0,8	± 1,2						
NAMA :									SKALA	DIGAMBAR	19/6/24	BILLY
RANGKA DUDUKAN BANTALAN									1 : 5	DIPERIKSA		
										DISAHKAN		
NO. ASSY :									FORMAT	SATUAN	NO GAMBAR	
POLITEKNIK NEGERI CILACAP, JURUSAN TEKNIK MESIN JL. dr. SOETOMO, NO. 01, SIDAKAYA, CILACAP, 53212 TELP : 0282-533329, E-mail : jtm@pnc.ac.id									A4	mm	PSD 12	

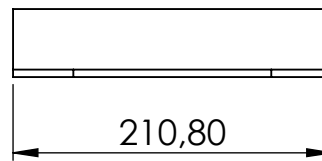
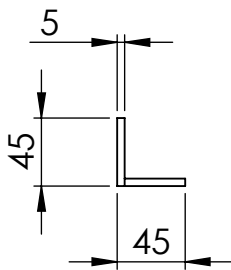
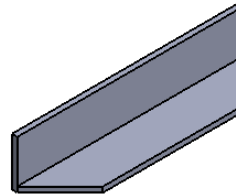
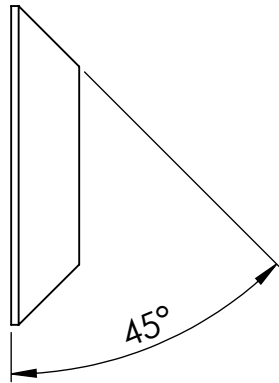

1	Rangka panjang Dudukan Box Air						Mildsteel	Lihat Detail	A9			
JML	NAMA BAGIAN						POS	BAHAN	UKURAN JADI	UKURAN KASAR	NO. ID	F
>	0	6	30	120	400	1000	PEKERJAAN LANJUT		NO ORDER			
<	6	30	120	400	1000	2000						
TOL	± 0,1	± 0,2	± 0,3	± 0,5	± 0,8	± 1,2						
NAMA :									SKALA	DIGAMBAR	19/6/24	BILLY
RANGKA PANJANG DUDUKAN BOX AIR									1 : 5	DIPERIKSA		
										DISAHKAN		
NO. ASSY :									FORMAT	SATUAN	NO GAMBAR	
POLITEKNIK NEGERI CILACAP, JURUSAN TEKNIK MESIN JL. dr. SOETOMO, NO. 01, SIDAKAYA, CILACAP, 53212 TELP : 0282-533329, E-mail : jtm@pnc.ac.id									A4	mm	PSD 13	

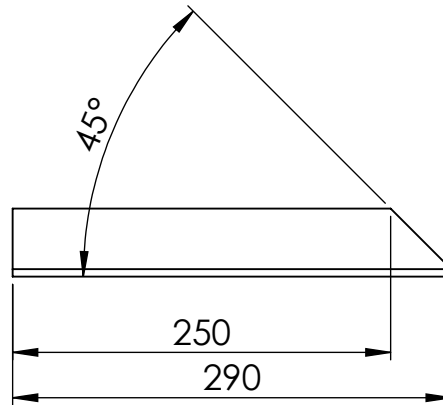
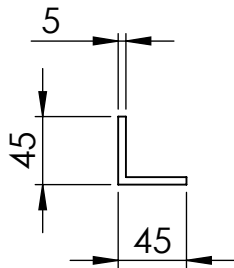
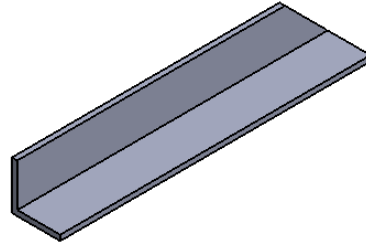

2	Rangka Lebar Dudukan Box Air						Mildsteel	Lihat Detail	A10			
JML	NAMA BAGIAN						POS	BAHAN	UKURAN JADI	UKURAN KASAR	NO. ID	F
>	0	6	30	120	400	1000	PEKERJAAN LANJUT	NO ORDER				
<	6	30	120	400	1000	2000						
TOL	± 0,1	± 0,2	± 0,3	± 0,5	± 0,8	± 1,2						
NAMA :									SKALA	DIGAMBAR	19/6/24	BILLY
RANGKA LEBAR DUDUKAN BOX AIR									1 : 5	DIPERIKSA		
										DISAHKAN		
NO. ASSY :									FORMAT	SATUAN	NO GAMBAR	
POLITEKNIK NEGERI CILACAP, JURUSAN TEKNIK MESIN JL. dr. SOETOMO, NO. 01, SIDAKAYA, CILACAP, 53212 TELP : 0282-533329, E-mail : jtm@pnc.ac.id									A4	mm	PSD 14	

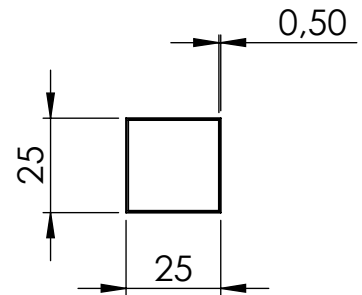
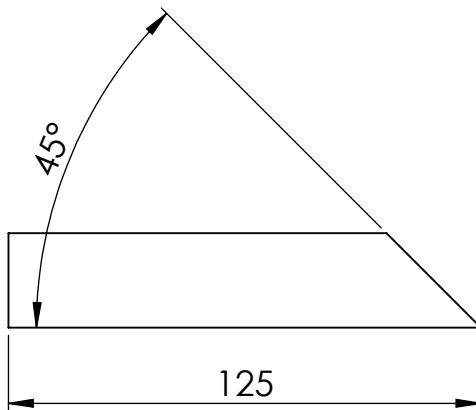
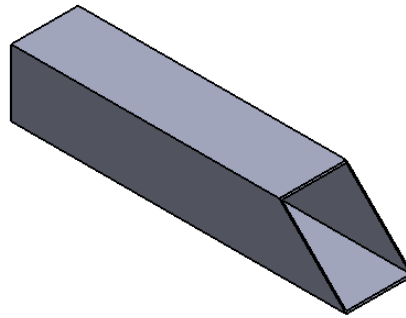

2	Rangka Lebar Dudukan Kontroler						Hollow Galvanis	Lihat Detail	A11			
JML	NAMA BAGIAN						POS	BAHAN	UKURAN JADI	UKURAN KASAR	NO. ID	F
>	0	6	30	120	400	1000	PEKERJAAN LANJUT		NO ORDER			
<	6	30	120	400	1000	2000						
TOL	± 0,1	± 0,2	± 0,3	± 0,5	± 0,8	± 1,2						
NAMA :									SKALA	DIGAMBAR	19/6/24	BILLY
RANGKA LEBAR DUDUKAN KONTROLER									1 : 2	DIPERIKSA		
										DISAHKAN		
NO. ASSY :									FORMAT	SATUAN	NO GAMBAR	
POLITEKNIK NEGERI CILACAP, JURUSAN TEKNIK MESIN JL. dr. SOETOMO, NO. 01, SIDAKAYA, CILACAP, 53212 TELP : 0282-533329, E-mail : jtm@pnc.ac.id									A4	mm	PSD 15	

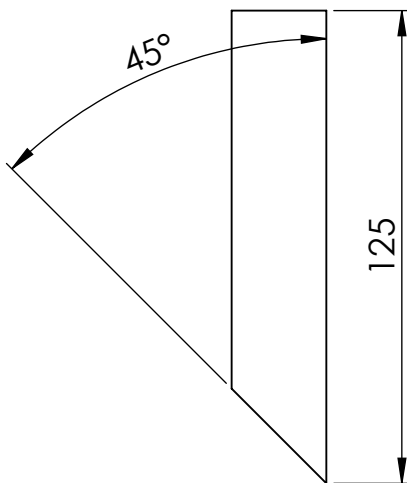
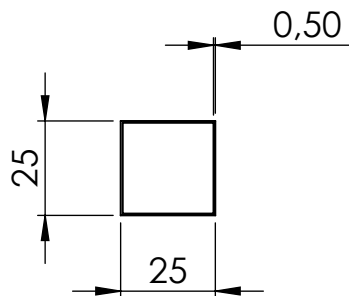

2	Rangka Tinggi Dudukan Kontroler						Hollow Galvanis	Lihat Detail	A13			
JML	NAMA BAGIAN						POS	BAHAN	UKURAN JADI	UKURAN KASAR	NO. ID	F
>	0	6	30	120	400	1000	PEKERJAAN LANJUT	NO ORDER				
<	6	30	120	400	1000	2000						
TOL	± 0,1	± 0,2	± 0,3	± 0,5	± 0,8	± 1,2						
NAMA :								SKALA	DIGAMBAR	19/6/24	BILLY	
RANGKA TINGGI DUDUKAN KONTROLER								1 : 2	DIPERIKSA			
									DISAHKAN			
NO. ASSY :								FORMAT	SATUAN	NO GAMBAR		
POLITEKNIK NEGERI CILACAP, JURUSAN TEKNIK MESIN JL. dr. SOETOMO, NO. 01, SIDAKAYA, CILACAP, 53212 TELP : 0282-533329, E-mail : jtm@pnc.ac.id								A4	mm	PSD 17		

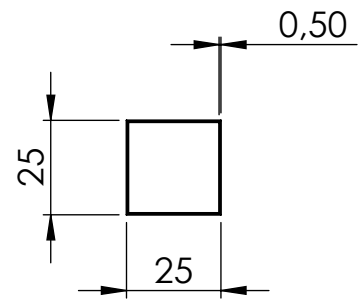
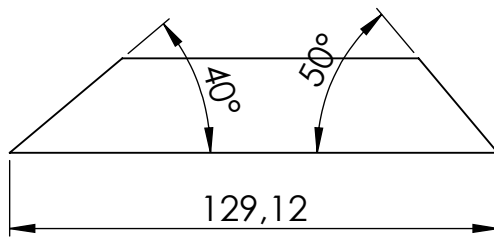
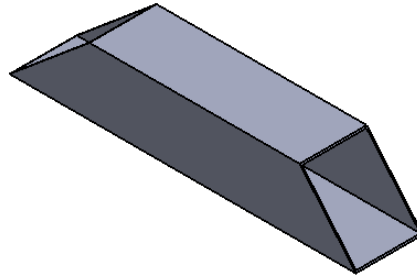

2	Rangka Miring						Hollow Galvanis	Lihat Detail	A12			
JML	NAMA BAGIAN						POS	BAHAN	UKURAN JADI	UKURAN KASAR	NO. ID	F
>	0	6	30	120	400	1000	PEKERJAAN LANJUT		NO ORDER			
<	6	30	120	400	1000	2000						
TOL	± 0,1	± 0,2	± 0,3	± 0,5	± 0,8	± 1,2						
NAMA :									SKALA	DIGAMBAR	19/6/24	BILLY
RANGKA MIRING									1 : 2	DIPERIKSA		
										DISAHKAN		
NO. ASSY :									FORMAT	SATUAN	NO GAMBAR	
POLITEKNIK NEGERI CILACAP, JURUSAN TEKNIK MESIN JL. dr. SOETOMO, NO. 01, SIDAKAYA, CILACAP, 53212 TELP : 0282-533329, E-mail : jtm@pnc.ac.id									A4	mm	PSD 16	

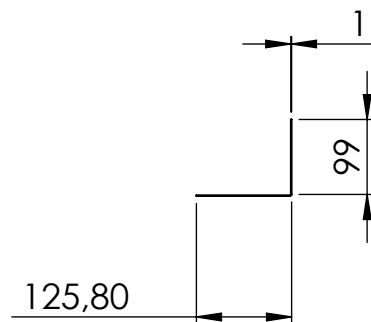
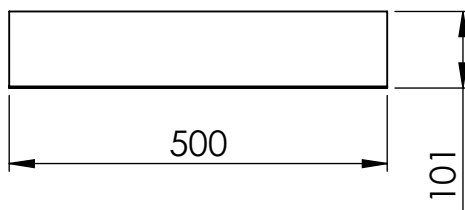
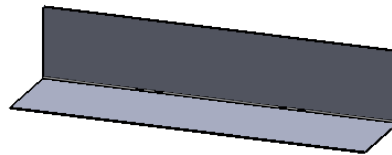
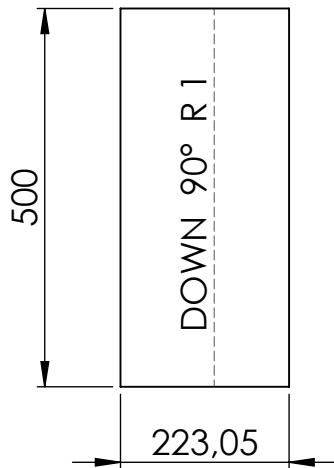

1	Tempat Kontroler						Plat	Lihat Detail			
JML	NAMA BAGIAN						POS	BAHAN	UKURAN JADI	UKURAN KASAR	NO. ID F
>	0	6	30	120	400	1000	PEKERJAAN LANJUT		NO ORDER		
<	6	30	120	400	1000	2000					
TOL	± 0,1	± 0,2	± 0,3	± 0,5	± 0,8	± 1,2					
NAMA : TEMPAT KONTROLER									SKALA 1 : 10	DIGAMBAR 19/6/24	BILLY
NO. ASSY :									DIPERIKSA		
									DISAHKAN		
POLITEKNIK NEGERI CILACAP, JURUSAN TEKNIK MESIN JL. dr. SOETOMO, NO. 01, SIDAKAYA, CILACAP, 53212 TELP : 0282-533329, E-mail : jtm@pnc.ac.id									FORMAT A4	SATUAN mm	NO GAMBAR PSD 18

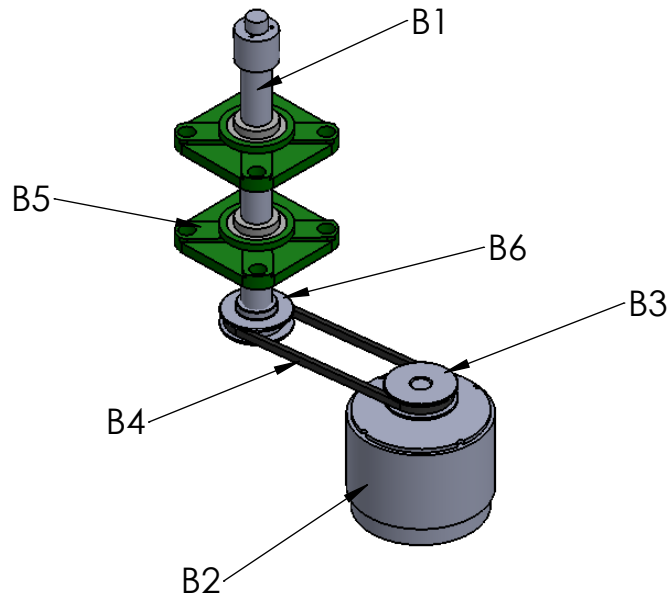

	Timing Pulley Poros		Alumunium	Lihat Detail		B6						
	Block Bearing			Lihat Detail		B5						
	Timing Belt		Karet	Lihat Detail		B4						
	Timing Pulley Motor		Alumunium	Lihat Detail		B3						
	Motor DC 1025			Lihat Detail		B2						
	Poros		S45C	Lihat Detail		B1						
JML	NAMA BAGIAN						POS	BAHAN	UKURAN JADI	UKURAN KASAR	NO. ID	F
>	0	6	30	120	400	1000	PEKERJAAN LANJUT		NO ORDER			
<	6	30	120	400	1000	2000						
TOL	± 0,1	± 0,2	± 0,3	± 0,5	± 0,8	± 1,2						
NAMA :									SKALA	DIGAMBAR	19/6/24	BILLY
TRANSMISI									1 : 5	DIPERIKSA		
										DISAHKAN		
NO. ASSY :									FORMAT	SATUAN	NO GAMBAR	
POLITEKNIK NEGERI CILACAP, JURUSAN TEKNIK MESIN JL. dr. SOETOMO, NO. 01, SIDAKAYA, CILACAP, 53212 TELP : 0282-533329, E-mail : jtm@pnc.ac.id									A4	mm	PSD 19	

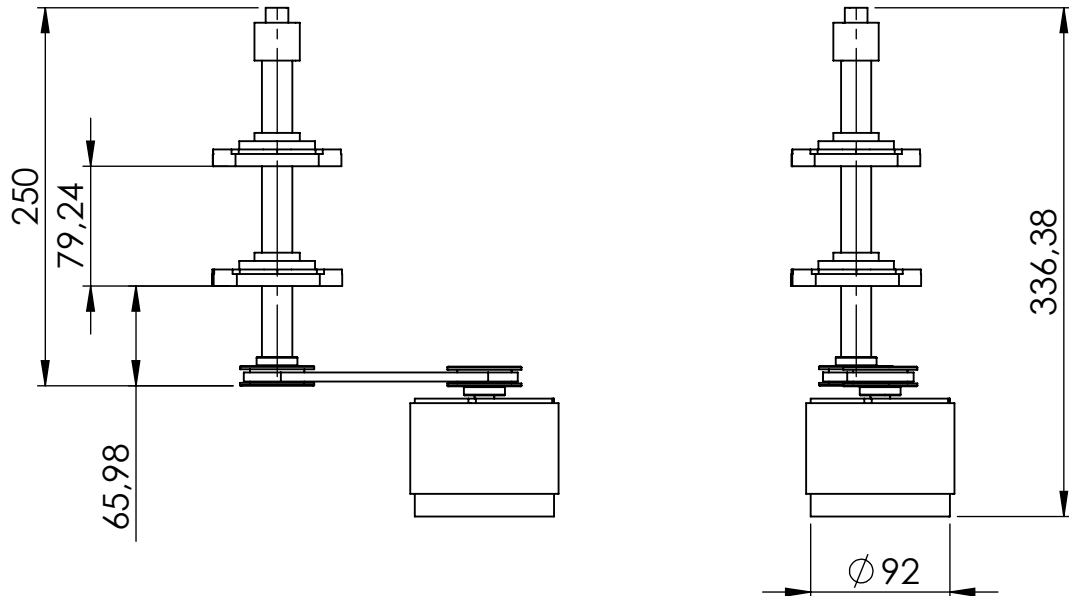
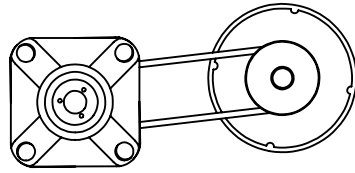

Assembly Transmisi							Lihat Detail					
JML	NAMA BAGIAN						POS	BAHAN	UKURAN JADI	UKURAN KASAR	NO. ID	F
>	0	6	30	120	400	1000	PEKERJAAN LANJUT		NO ORDER			
<	6	30	120	400	1000	2000						
TOL	± 0,1	± 0,2	± 0,3	± 0,5	± 0,8	± 1,2						
NAMA : ASSEMBLY TRANSMISI									SKALA 1 : 5	DIGAMBAR 20/6/24	BILLY	
NO. ASSY :										DIPERIKSA		
										DISAHKAN		
POLITEKNIK NEGERI CILACAP, JURUSAN TEKNIK MESIN JL. dr. SOETOMO, NO. 01, SIDAKAYA, CILACAP, 53212 TELP : 0282-533329, E-mail : jtm@pnc.ac.id									FORMAT A4	SATUAN mm	NO GAMBAR PSD 20	

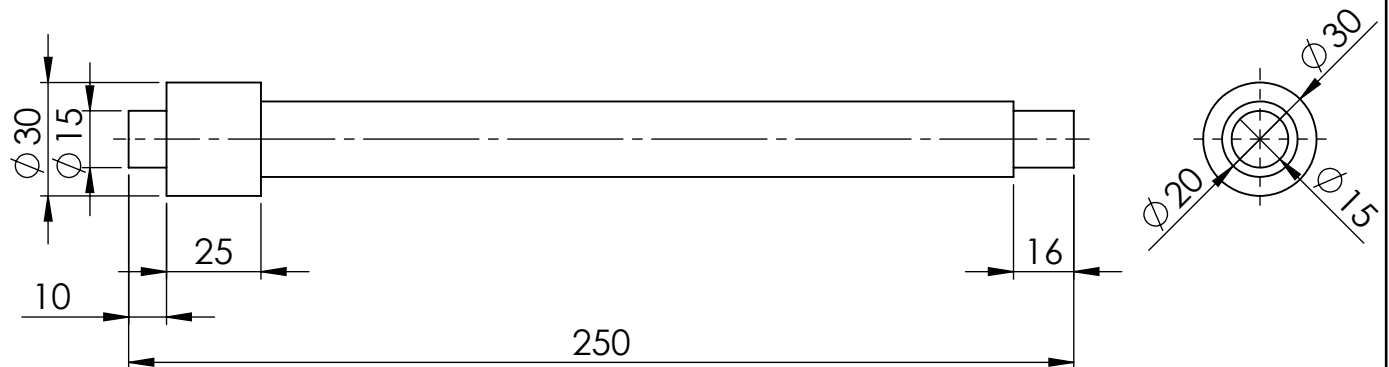
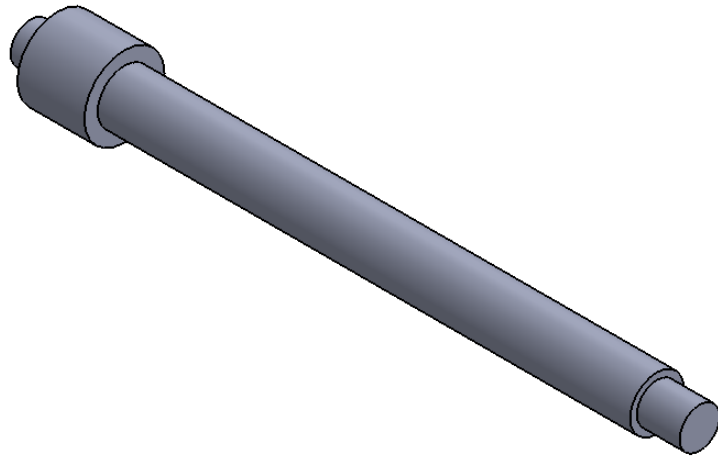

1	Poros						S45C	Lihat Detail	B1			
JML	NAMA BAGIAN						POS	BAHAN	UKURAN JADI	UKURAN KASAR	NO. ID	F
>	0	6	30	120	400	1000	PEKERJAAN LANJUT		NO ORDER			
<	6	30	120	400	1000	2000						
TOL	± 0,1	± 0,2	± 0,3	± 0,5	± 0,8	± 1,2						
NAMA :									SKALA	DIGAMBAR	20/6/24	BILLY
POROS									1 : 2	DIPERIKSA		
										DISAHKAN		
NO. ASSY :									FORMAT	SATUAN	NO GAMBAR	
POLITEKNIK NEGERI CILACAP, JURUSAN TEKNIK MESIN JL. dr. SOETOMO, NO. 01, SIDAKAYA, CILACAP, 53212 TELP : 0282-533329, E-mail : jtm@pnc.ac.id									A4	mm	PSD 21	

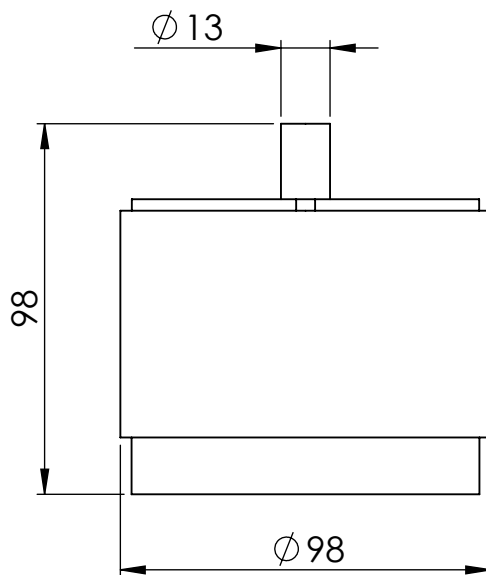
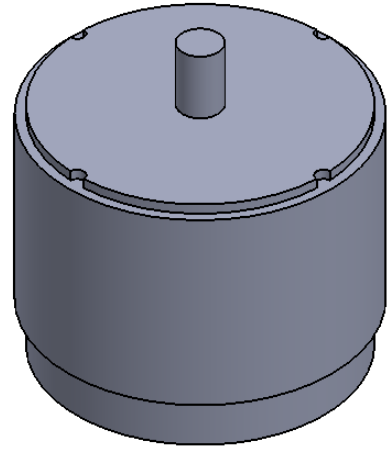
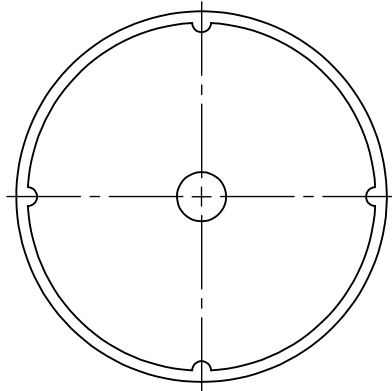

1	Motor DC 1025							Lihat Detail		B2		
JML	NAMA BAGIAN						POS	BAHAN	UKURAN JADI	UKURAN KASAR	NO. ID	F
>	0	6	30	120	400	1000	PEKERJAAN LANJUT		NO ORDER			
<	6	30	120	400	1000	2000						
TOL	± 0,1	± 0,2	± 0,3	± 0,5	± 0,8	± 1,2						
NAMA :									SKALA	DIGAMBAR	20/6/24	BILLY
MOTOR DC 1025									1 : 2	DIPERIKSA		
										DISAHKAN		
NO. ASSY :									FORMAT	SATUAN	NO GAMBAR	
POLITEKNIK NEGERI CILACAP, JURUSAN TEKNIK MESIN JL. dr. SOETOMO, NO. 01, SIDAKAYA, CILACAP, 53212 TELP : 0282-533329, E-mail : jtm@pnc.ac.id									A4	mm	PSD 22	

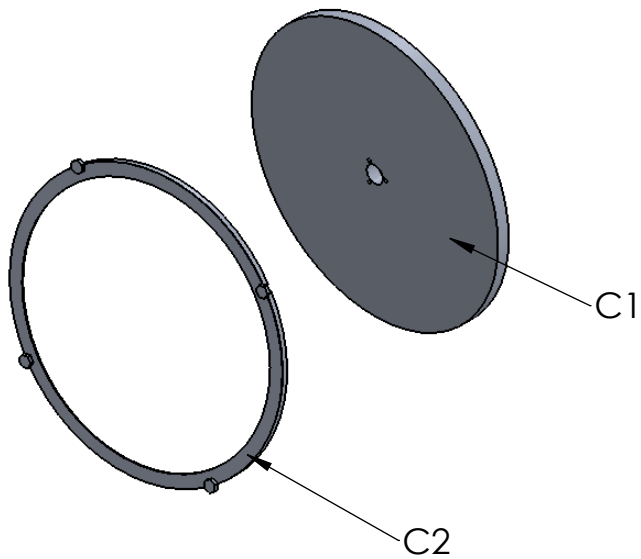

1	Cincin Piringan							Plat	Lihat Detail		C2	
1	Piringan							Alumunium	Lihat Detail		C1	
JML	NAMA BAGIAN						POS	BAHAN	UKURAN JADI	UKURAN KASAR	NO. ID	F
>	0	6	30	120	400	1000	PEKERJAAN LANJUT		NO ORDER			
<	6	30	120	400	1000	2000						
TOL	± 0,1	± 0,2	± 0,3	± 0,5	± 0,8	± 1,2						
NAMA :									SKALA	DIGAMBAR	22/6/24	BILLY
ASSEMBLY PIRINGAN									1 : 10	DIPERIKSA		
										DISAHKAN		
NO. ASSY :									FORMAT	SATUAN	NO GAMBAR	
POLITEKNIK NEGERI CILACAP, JURUSAN TEKNIK MESIN JL. dr. SOETOMO, NO. 01, SIDAKAYA, CILACAP, 53212 TELP : 0282-533329, E-mail : jtm@pnc.ac.id									A4	mm	PSD 23	

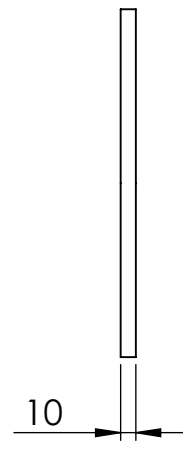
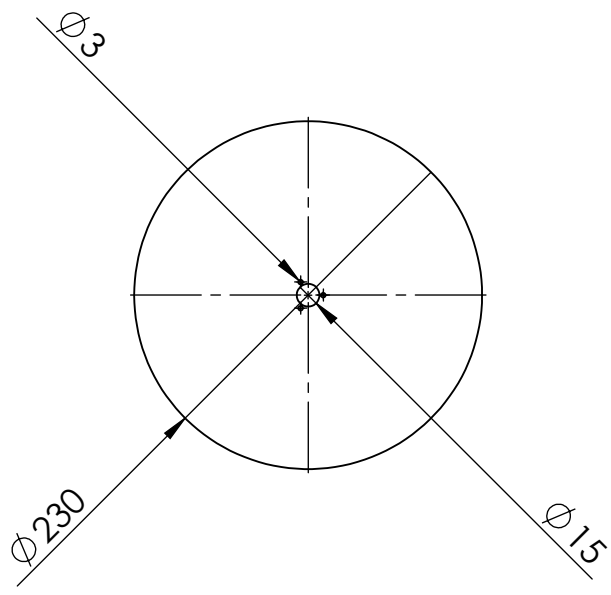
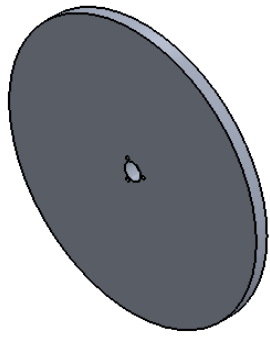

1	Piringan						Alumunium	Lihat Detail		C1		
JML	NAMA BAGIAN						POS	BAHAN	UKURAN JADI	UKURAN KASAR	NO. ID F	
>	0	6	30	120	400	1000	PEKERJAAN LANJUT		NO ORDER			
<	6	30	120	400	1000	2000						
TOL	± 0,1	± 0,2	± 0,3	± 0,5	± 0,8	± 1,2						
NAMA :									SKALA	DIGAMBAR	22/6/24	BILLY
<h1>PIRINGAN</h1>									1 : 5	DIPERIKSA		
										DISAHKAN		
NO. ASSY :									FORMAT	SATUAN	NO GAMBAR	
POLITEKNIK NEGERI CILACAP, JURUSAN TEKNIK MESIN JL. dr. SOETOMO, NO. 01, SIDAKAYA, CILACAP, 53212 TELP : 0282-533329, E-mail : jtm@pnc.ac.id									A4	mm	PSD 24	

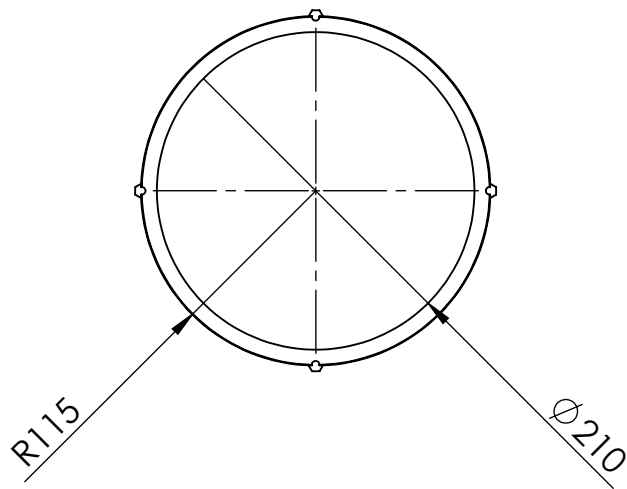
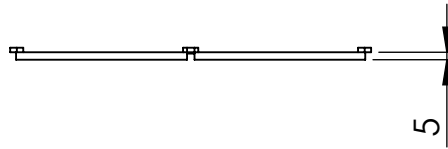

1	Cincin Piringan						Plat	Lihat Detail	C2			
JML	NAMA BAGIAN						POS	BAHAN	UKURAN JADI	UKURAN KASAR	NO. ID	F
>	0	6	30	120	400	1000	PEKERJAAN LANJUT		NO ORDER			
<	6	30	120	400	1000	2000						
TOL	± 0,1	± 0,2	± 0,3	± 0,5	± 0,8	± 1,2						
NAMA :								SKALA	DIGAMBAR	22/6/24	BILLY	
CINCIN PIRINGAN								1 : 5	DIPERIKSA			
									DISAHKAN			
NO. ASSY :								FORMAT	SATUAN	NO GAMBAR		
POLITEKNIK NEGERI CILACAP, JURUSAN TEKNIK MESIN JL. dr. SOETOMO, NO. 01, SIDAKAYA, CILACAP, 53212 TELP : 0282-533329, E-mail : jtm@pnc.ac.id								A4	mm	PSD 25		

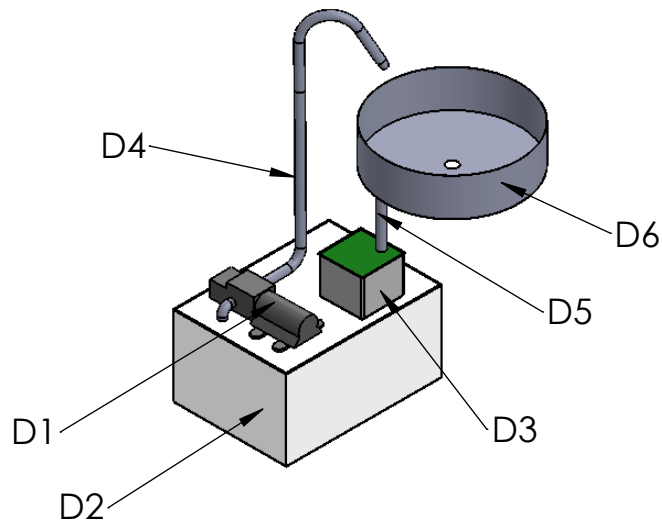

1	Wadah Air Pemolesan							Plat	Lihat Detail		D6		
1	Selang Keluar							Plastik	Lihat Detail		D5		
1	Selang Masuk							Plastik	Lihat Detail		D4		
1	Filter Air							Plastik	Lihat Detail		D3		
1	Box Air							Plastik	Lihat Detail		D2		
1	Pompa							Plastik	Lihat Detail		D1		
JML	NAMA BAGIAN						POS	BAHAN	UKURAN JADI	UKURAN KASAR	NO. ID	F	
>	0	6	30	120	400	1000	PEKERJAAN LANJUT			NO ORDER			
<	6	30	120	400	1000	2000							
TOL	± 0,1	± 0,2	± 0,3	± 0,5	± 0,8	± 1,2							
NAMA :										SKALA	DIGAMBAR	24/6/24	BILLY
SISTEM SIRKULASI AIR										1 : 10	DIPERIKSA		
											DISAHKAN		
NO. ASSY :										FORMAT	SATUAN	NO GAMBAR	
POLITEKNIK NEGERI CILACAP, JURUSAN TEKNIK MESIN JL. dr. SOETOMO, NO. 01, SIDAKAYA, CILACAP, 53212 TELP : 0282-533329, E-mail : jtm@pnc.ac.id										A4	mm	PSD 26	

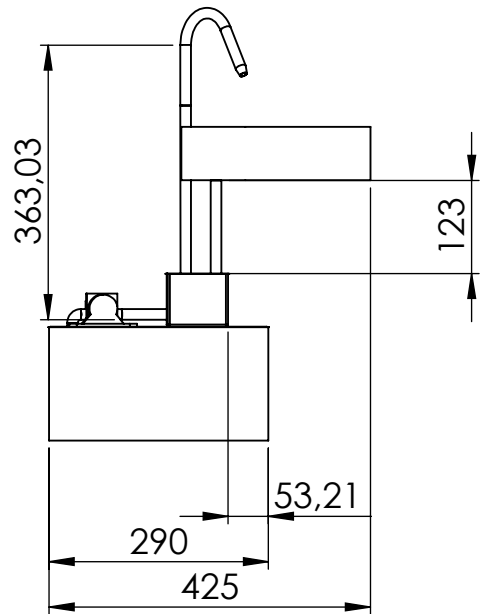
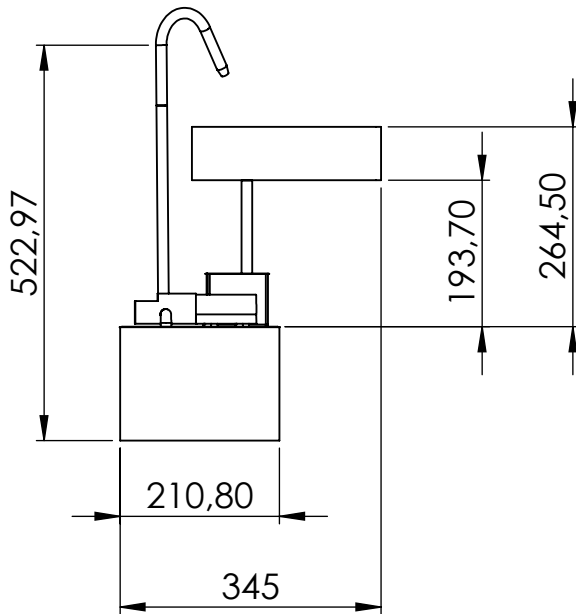
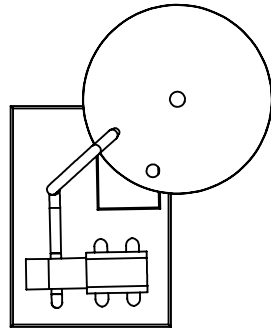

JML	NAMA BAGIAN						POS	BAHAN	UKURAN JADI	UKURAN KASAR	NO. ID	F
>	0	6	30	120	400	1000	PEKERJAAN LANJUT		NO ORDER			
<	6	30	120	400	1000	2000						
TOL	± 0,1	± 0,2	± 0,3	± 0,5	± 0,8	± 1,2						
NAMA :									SKALA	DIGAMBAR	24/6/24	BILLY
SISTEM SIRKULASI AIR									1 : 10	DIPERIKSA		
										DISAHKAN		
NO. ASSY :									FORMAT	SATUAN	NO GAMBAR	
POLITEKNIK NEGERI CILACAP, JURUSAN TEKNIK MESIN JL. dr. SOETOMO, NO. 01, SIDAKAYA, CILACAP, 53212 TELP : 0282-533329, E-mail : jtm@pnc.ac.id									A4	mm	PSD 27	

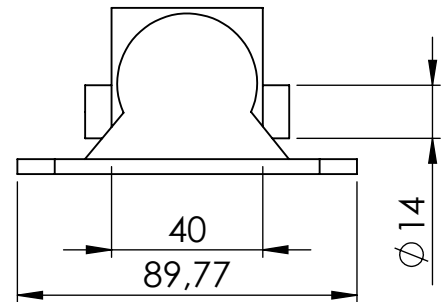
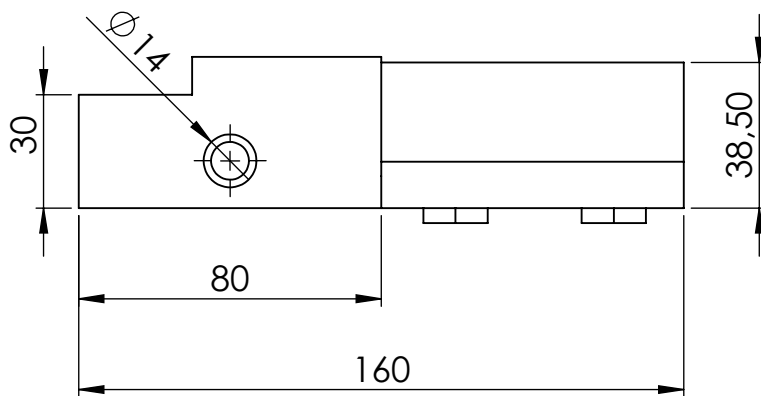
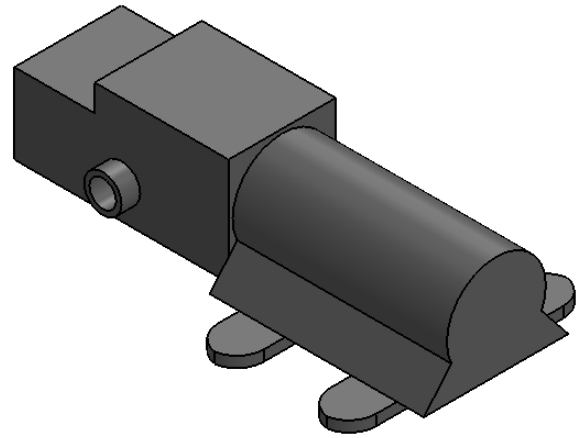
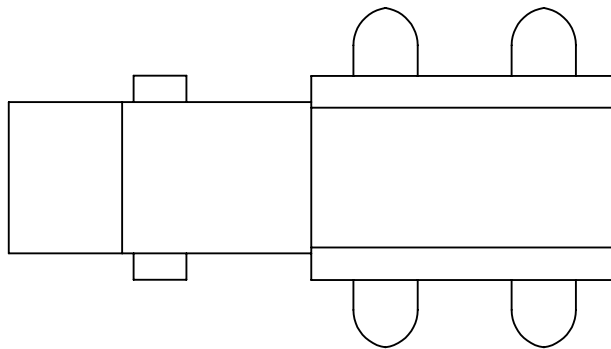

1	Pompa						Plastik	Lihat Detail	D1			
JML	NAMA BAGIAN						POS	BAHAN	UKURAN JADI	UKURAN KASAR	NO. ID	F
>	0	6	30	120	400	1000	PEKERJAAN LANJUT		NO ORDER			
<	6	30	120	400	1000	2000						
TOL	$\pm 0,1$	$\pm 0,2$	$\pm 0,3$	$\pm 0,5$	$\pm 0,8$	$\pm 1,2$						
NAMA :									SKALA	DIGAMBAR	24/6/24	BILLY
POMPA									1 : 2	DIPERIKSA		
										DISAHKAN		
NO. ASSY :									FORMAT	SATUAN	NO GAMBAR	
POLITEKNIK NEGERI CILACAP, JURUSAN TEKNIK MESIN JL. dr. SOETOMO, NO. 01, SIDAKAYA, CILACAP, 53212 TELP : 0282-533329, E-mail : jtm@pnc.ac.id									A4	mm	PSD 28	

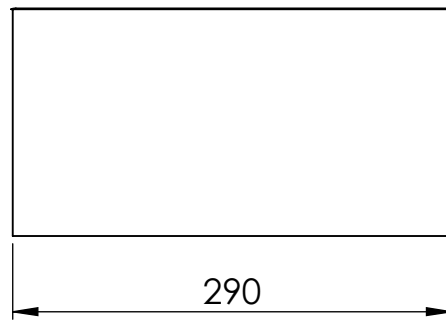
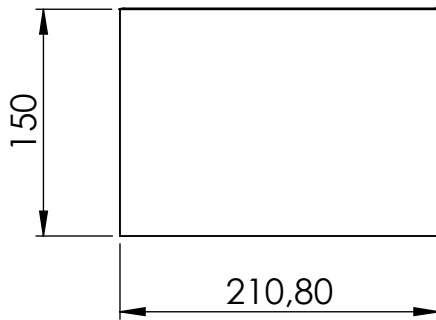
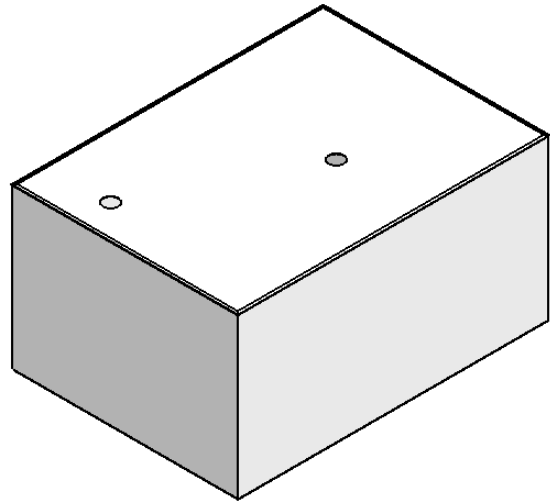
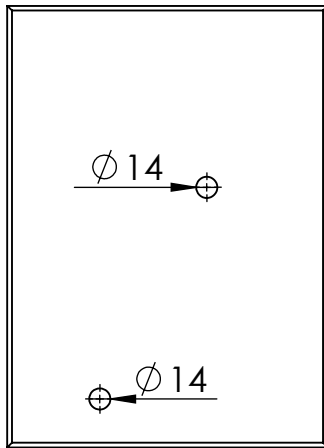

1	Box Air						Plastik	Lihat Detail	D2			
JML	NAMA BAGIAN						POS	BAHAN	UKURAN JADI	UKURAN KASAR	NO. ID	F
>	0	6	30	120	400	1000	PEKERJAAN LANJUT		NO ORDER			
<	6	30	120	400	1000	2000						
TOL	± 0,1	± 0,2	± 0,3	± 0,5	± 0,8	± 1,2						
NAMA :									SKALA	DIGAMBAR	24/6/24	BILLY
BOX AIR									1 : 5	DIPERIKSA		
										DISAHKAN		
NO. ASSY :									FORMAT	SATUAN	NO GAMBAR	
POLITEKNIK NEGERI CILACAP, JURUSAN TEKNIK MESIN JL. dr. SOETOMO, NO. 01, SIDAKAYA, CILACAP, 53212 TELP : 0282-533329, E-mail : jtm@pnc.ac.id									A4	mm	PSD 29	

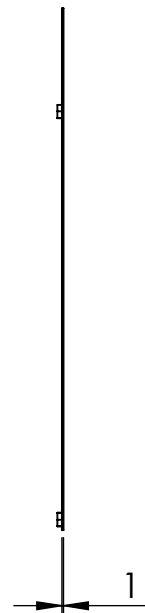
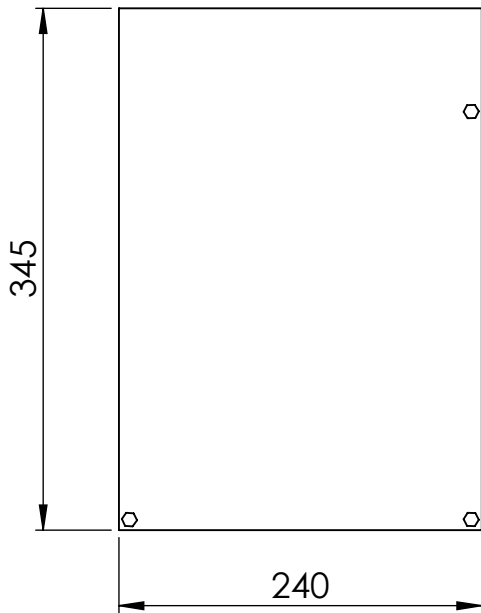
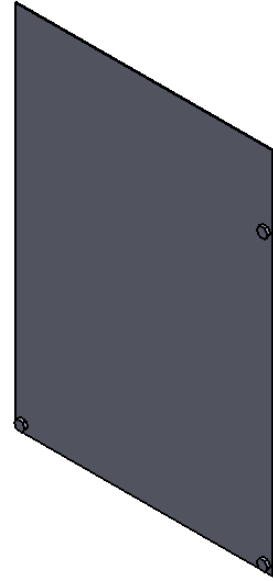

1	Cover Depan						Plat	Lihat Detail		F		
JML	NAMA BAGIAN						POS	BAHAN	UKURAN JADI	UKURAN KASAR	NO. ID	F
>	0	6	30	120	400	1000	PEKERJAAN LANJUT		NO ORDER			
<	6	30	120	400	1000	2000						
TOL	± 0,1	± 0,2	± 0,3	± 0,5	± 0,8	± 1,2						
NAMA :									SKALA	DIGAMBAR	24/6/24	BILLY
Cover Depan									1 : 5	DIPERIKSA		
										DISAHKAN		
NO. ASSY :									FORMAT	SATUAN	NO GAMBAR	
POLITEKNIK NEGERI CILACAP, JURUSAN TEKNIK MESIN JL. dr. SOETOMO, NO. 01, SIDAKAYA, CILACAP, 53212 TELP : 0282-533329, E-mail : jtm@pnc.ac.id									A4	mm	PSD 30	

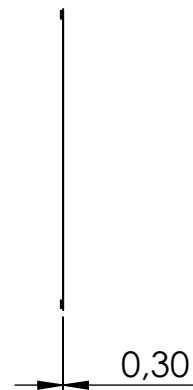
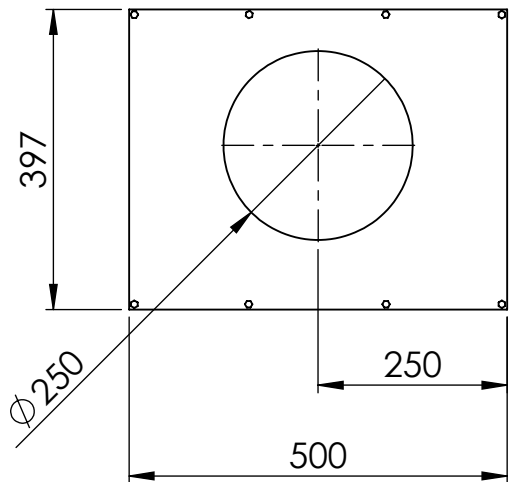
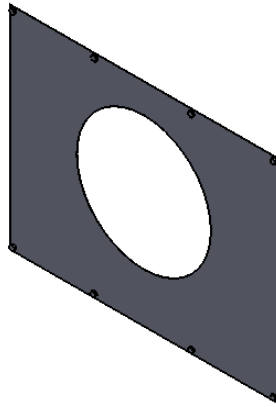

1	Cover Atas						Plat	Lihat Detail		F		
JML	NAMA BAGIAN						POS	BAHAN	UKURAN JADI	UKURAN KASAR	NO. ID F	
>	0	6	30	120	400	1000	PEKERJAAN LANJUT		NO ORDER			
<	6	30	120	400	1000	2000						
TOL	± 0,1	± 0,2	± 0,3	± 0,5	± 0,8	± 1,2						
NAMA :									SKALA	DIGAMBAR	24/6/24	BILLY
COVER ATAS									1 : 10	DIPERIKSA		
										DISAHKAN		
NO. ASSY :									FORMAT	SATUAN	NO GAMBAR	
POLITEKNIK NEGERI CILACAP, JURUSAN TEKNIK MESIN JL. dr. SOETOMO, NO. 01, SIDAKAYA, CILACAP, 53212 TELP : 0282-533329, E-mail : jtm@pnc.ac.id									A4	mm	PSD 31	

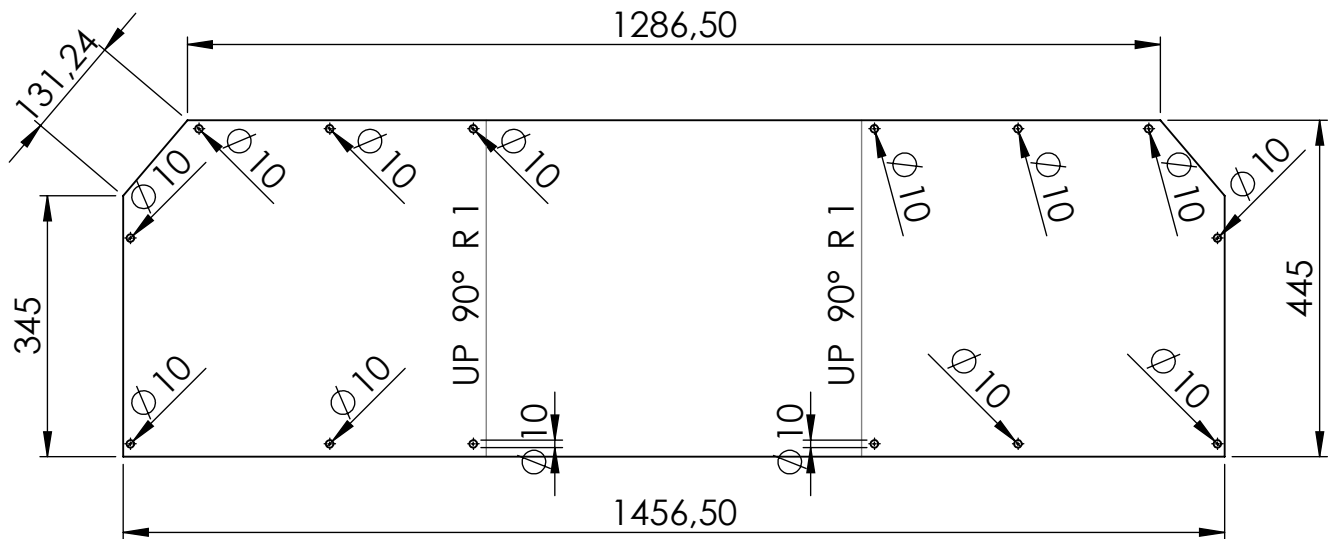
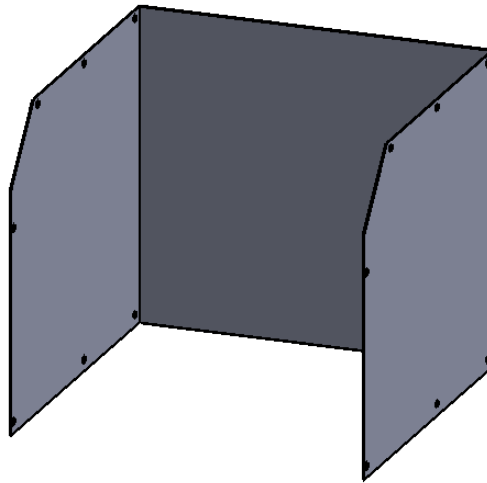

1	Cover Belakang						Plat	Lihat Detail	F			
JML	NAMA BAGIAN						POS	BAHAN	UKURAN JADI	UKURAN KASAR	NO. ID	F
>	0	6	30	120	400	1000	PEKERJAAN LANJUT	NO ORDER				
<	6	30	120	400	1000	2000						
TOL	± 0,1	± 0,2	± 0,3	± 0,5	± 0,8	± 1,2						
NAMA :								SKALA	DIGAMBAR	24/6/24	BILLY	
COVER BELAKANG								1 : 10	DIPERIKSA			
									DISAHKAN			
NO. ASSY :								FORMAT	SATUAN	NO GAMBAR		
POLITEKNIK NEGERI CILACAP, JURUSAN TEKNIK MESIN JL. dr. SOETOMO, NO. 01, SIDAKAYA, CILACAP, 53212 TELP : 0282-533329, E-mail : jtm@pnc.ac.id								A4	mm	PSD 32		