

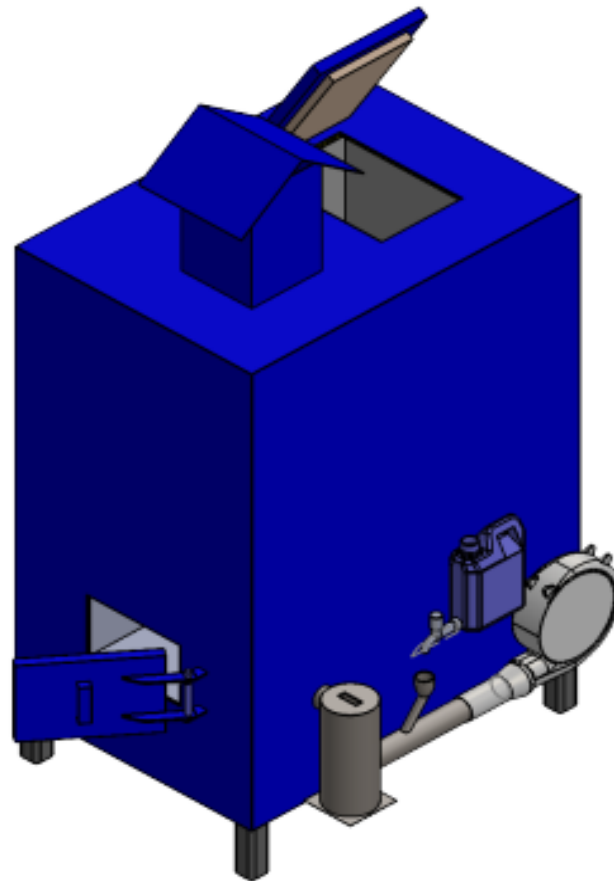

LAMPIRAN 1
(DESAIN INCINERATOR)

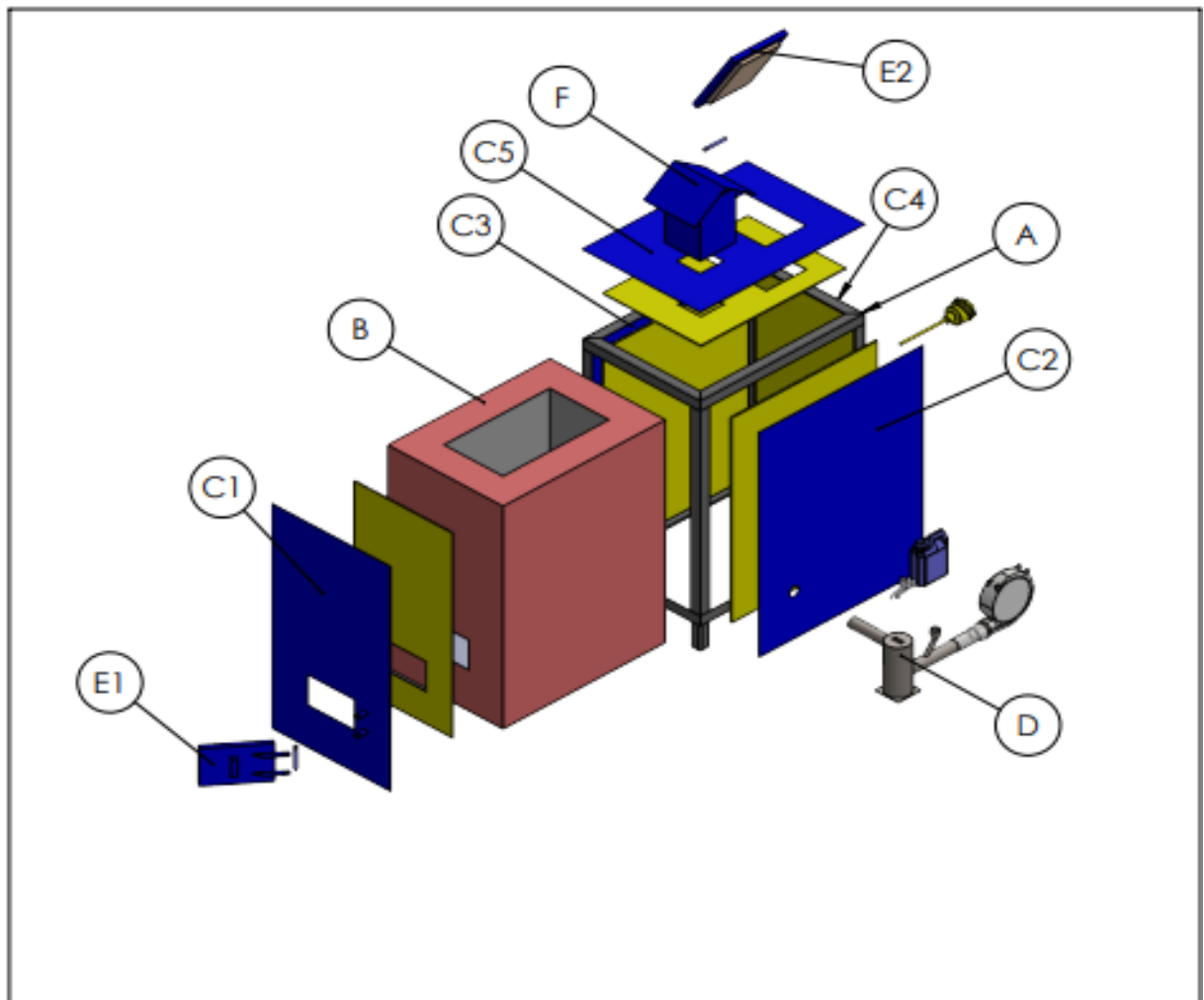

JML	NAMA BAGIAN						BAHAN	UKURAN JADI	UKURAN KASAR	NO. ID	KETERANGAN	
>	0	6	30	120	400	1000	Pengerjaan Lanjut		NO. ORDER	PROYEKSI		
<	6	30	120	400	1000	2000						
TOL	±0.1	±0.2	±0.3	±0.5	±0.8	±1.2						
INCINERATOR									SKALA	DIGAMBAR		AKBAR
									1:10	DIPERIKSA		
										DISAHKAN		
POLITEKNIK NEGERI CILACAP									FORMAT	NO. GAMBAR		
									A4	ILM/01		



1	RANGKA	MILD STEEL	-	-	A	-
1	LAPISAN BATA SEMEN	SEMEN & BATA	-	-	B	-
5	COVER INCINERATOR	MILD STEEL	-	-	C	-
1	SUB ASSY BURNER	MILD STEEL	-	-	D	-
2	PINTU INCINERATOR	MILD STEEL	-	-	E	-
1	CEROBONG ASAP	MILD STEEL	-	-	F	-
JML	NAMA BAGIAN	BAHAN	UKURAN JADI	UKURAN KASAR	NO. ID	KETERANGAN
>	0	6	30	120	400	1000
<	6	30	120	400	1000	2000
TOL	±0.1	±0.2	±0.3	±0.5	±0.8	±1.2
Pengerjaan Lanjut				NO. ORDER		PROYEKSI
ASSY INCINERATOR				SKALA	DIGAMBAR	AKBAR
				1:20	DIPERIKSA	
					DISAHKAN	
 POLITEKNIK NEGERI CILACAP				FORMAT	NO. GAMBAR	
				A4	ILM/02	

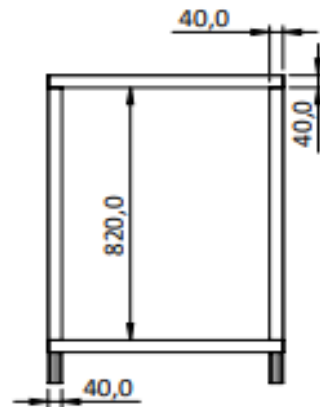
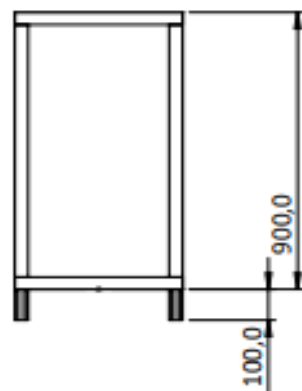
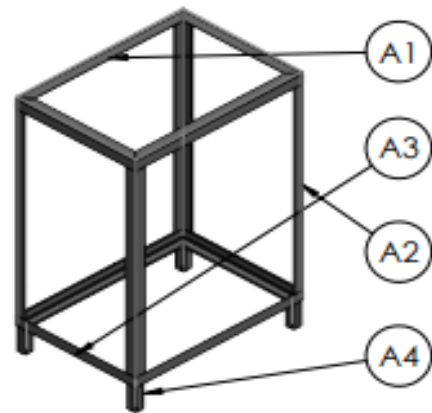
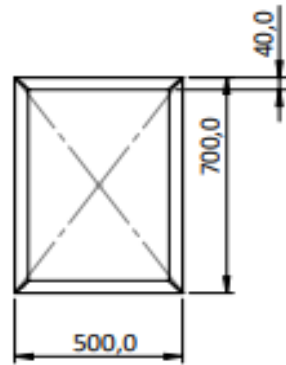

4	RANGKA PANJANG	MILD STEEL	LIHAT DETAIL	-	A1	-
4	RANGKA TINGGI	MILD STEEL	LIHAT DETAIL	-	A2	-
4	RANGKA LEBAR	MILD STEEL	LIHAT DETAIL	-	A3	-
4	KAKI	MILD STEEL	LIHAT DETAIL	-	A4	-

JML	NAMA BAGIAN						BAHAN	UKURAN JADI	UKURAN KASAR	NO. ID	KETERANGAN
>	0	6	30	120	400	1000	PENGKERJAAN LANJUT		NO. ORDER		
<	6	30	120	400	1000	2000					
TOL	±0.1	±0.2	±0.3	±0.5	±0.8	±1.2					

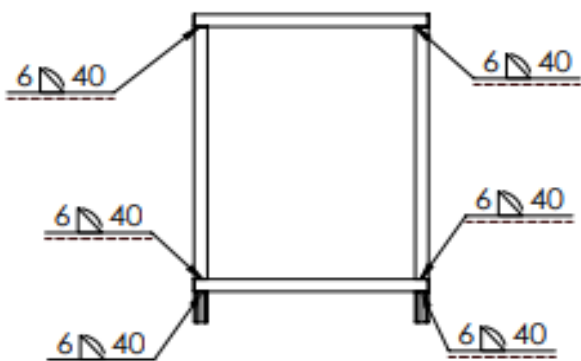
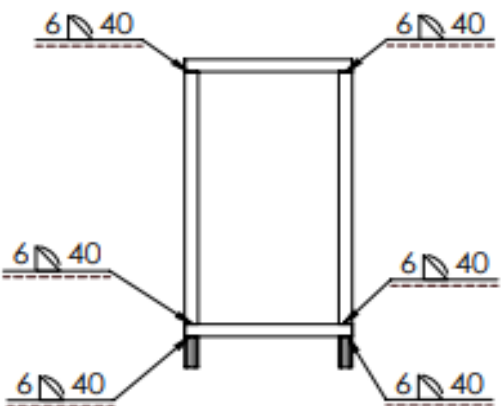
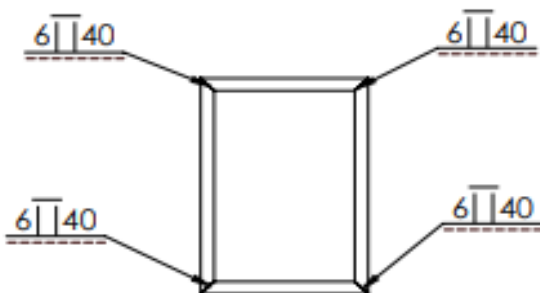

RANGKA	SKALA	DIGAMBAR	AKBAR
	1:20	DIPERIKSA	
		DISAHKAN	

POLITEKNIK NEGERI CILACAP	FORMAT A4	NO. GAMBAR ILM/03
----------------------------------	---------------------	-----------------------------

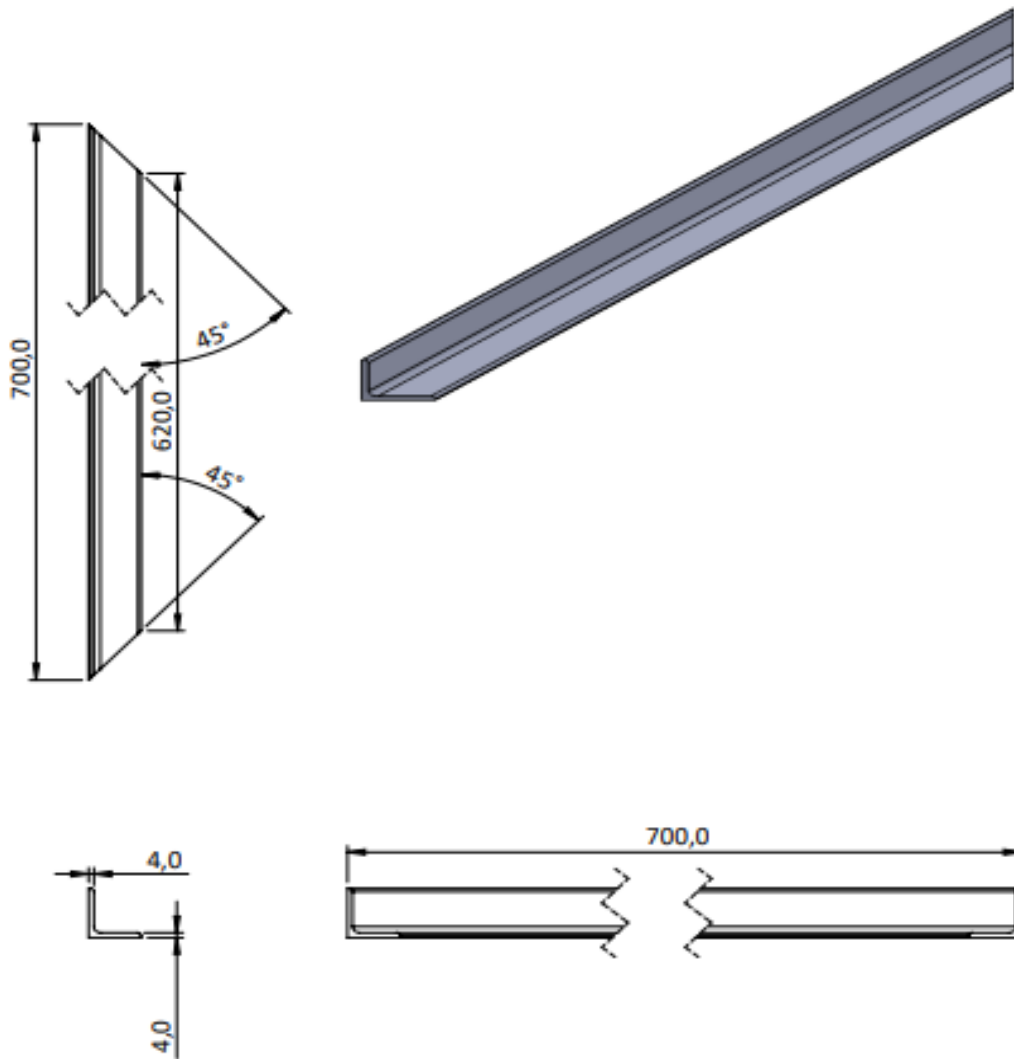

JML	NAMA BAGIAN					BAHAN	UKURAN JADI	UKURAN KASAR	NO. ID	KETERANGAN
>	0	6	30	120	400	1000	PENGKERJAAN LANJUT	NO. ORDER	PROYEKSI AKBAR	
<	6	30	120	400	1000	2000				
TOL	±0.1	±0.2	±0.3	±0.5	±0.8	±1.2				
SIMBOL PENGELASAN RANGKA								SKALA	DIGAMBAR	
								1:20	DIPERIKSA	
									DISAHKAN	
POLITEKNIK NEGERI CILACAP								FORMAT	NO. GAMBAR	
								A4	ILM/04	



JML	NAMA BAGIAN						BAHAN	UKURAN JADI	UKURAN KASAR	NO. ID	KETERANGAN
>	0	6	30	120	400	1000	PENGERJAAN LANJUT	NO. ORDER		PROYEKSI 	
<	6	30	120	400	1000	2000					
TOL	±0.1	±0.2	±0.3	±0.5	±0.8	±1.2					
RANGKA PANJANG									SKALA	DIGAMBAR	AKBAR
									1:5	DIPERIKSA	
 POLITEKNIK NEGERI CILACAP									FORMAT	NO. GAMBAR	
									A4	ILM/05	

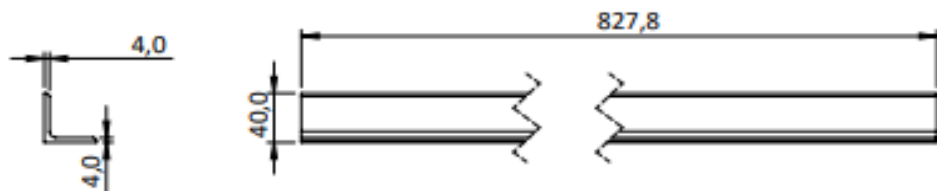
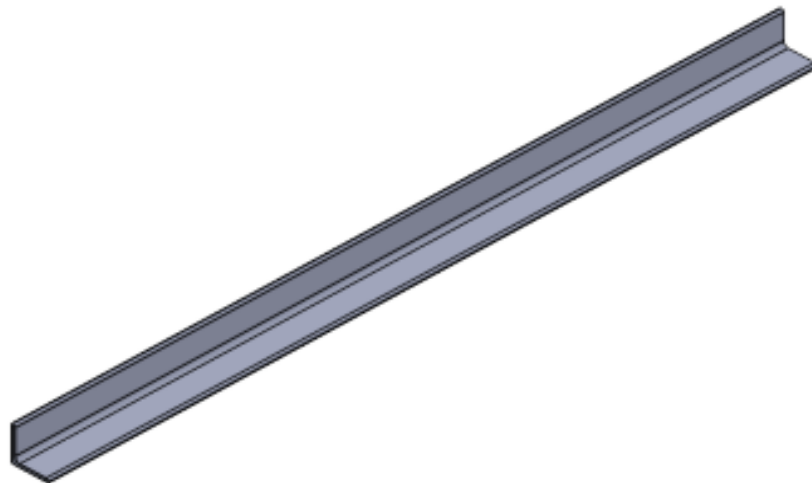

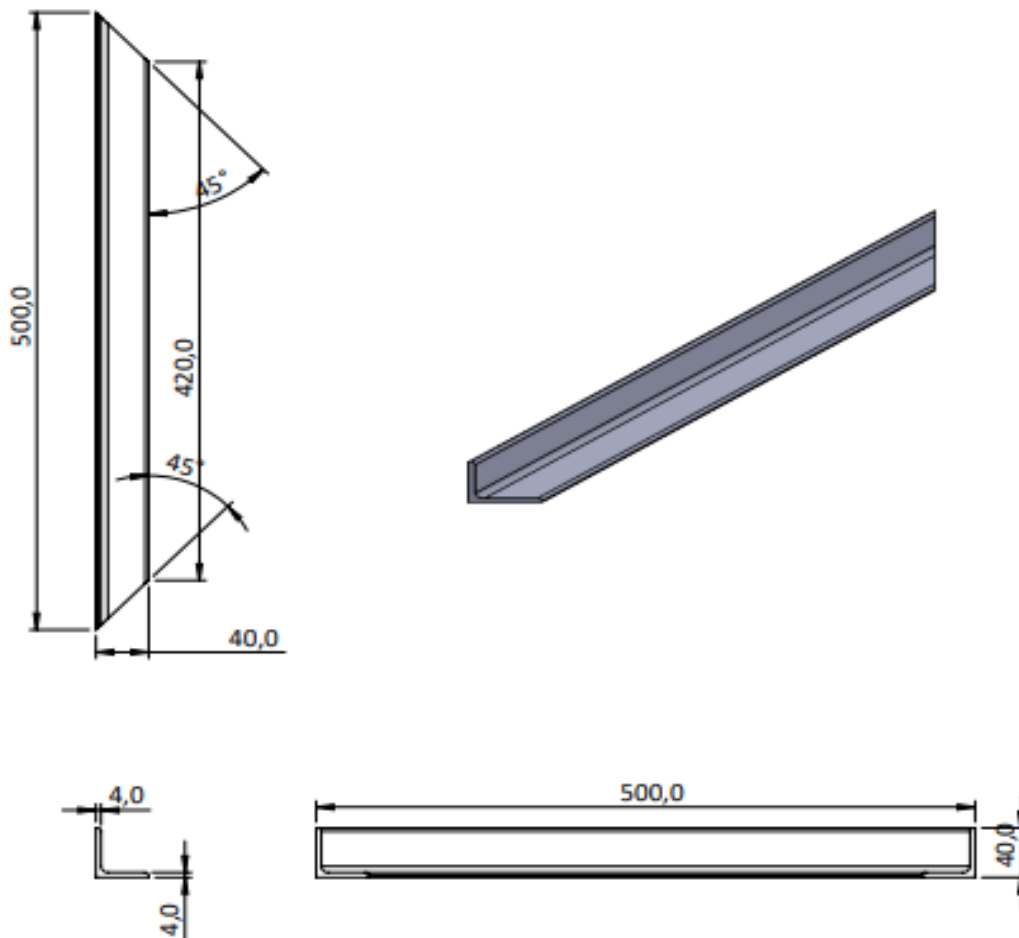

JML	NAMA BAGIAN						BAHAN	UKURAN JADI	UKURAN KASAR	NO. ID	KETERANGAN
>	0	6	30	120	400	1000	Pengerjaan Lanjut	NO. ORDER	PROYEKSI		
<	6	30	120	400	1000	2000					
TOL	±0.1	±0.2	±0.3	±0.5	±0.8	±1.2					
RANGKA TINGGI									SKALA	DIGAMBAR	AKBAR
									1:5	DIPERIKSA	
										DISAHKAN	
 POLITEKNIK NEGERI CILACAP									FORMAT	NO. GAMBAR	
									A4	ILM/06	

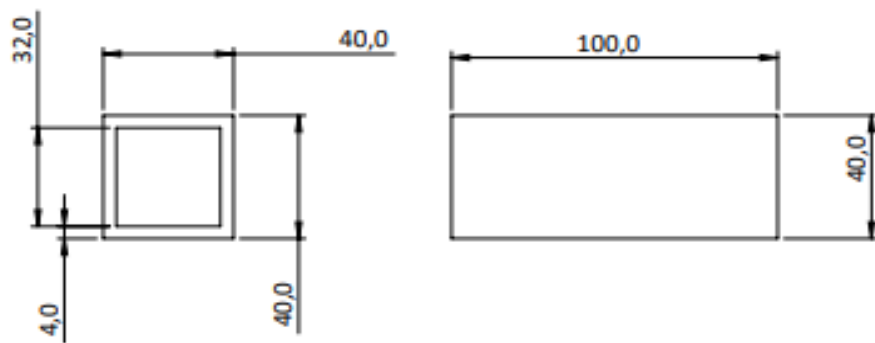
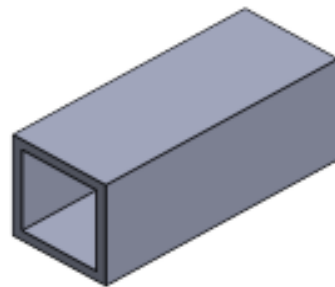

JML	NAMA BAGIAN						BAHAN	UKURAN JADI	UKURAN KASAR	NO. ID	KETERANGAN
>	0	6	30	120	400	1000	PENGKERJAAN LANJUT	NO. ORDER		PROYEKSI	
<	6	30	120	400	1000	2000				AKBAR	
TOL	±0.1	±0.2	±0.3	±0.5	±0.8	±1.2					
RANGKA LEBAR									SKALA	DIGAMBAR	
									1:5	DIPERIKSA	
										DISAHKAN	
POLITEKNIK NEGERI CILACAP									FORMAT	NO. GAMBAR	
									A4	ILM/07	

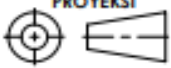

JML	NAMA BAGIAN						BAHAN	UKURAN JADI	UKURAN KASAR	NO. ID	KETERANGAN
>	0	6	30	120	400	1000	PENGKERJAAN LANJUT	NO. ORDER		PROYEKSI 	
<	6	30	120	400	1000	2000					
TOL	±0.1	±0.2	±0.3	±0.5	±0.8	±1.2					
KAKI									SKALA	DIGAMBAR	AKBAR
									1:2	DIPERIKSA	
										DISAHKAN	
 POLITEKNIK NEGERI CILACAP									FORMAT	NO. GAMBAR	
									A4	ILM/08	

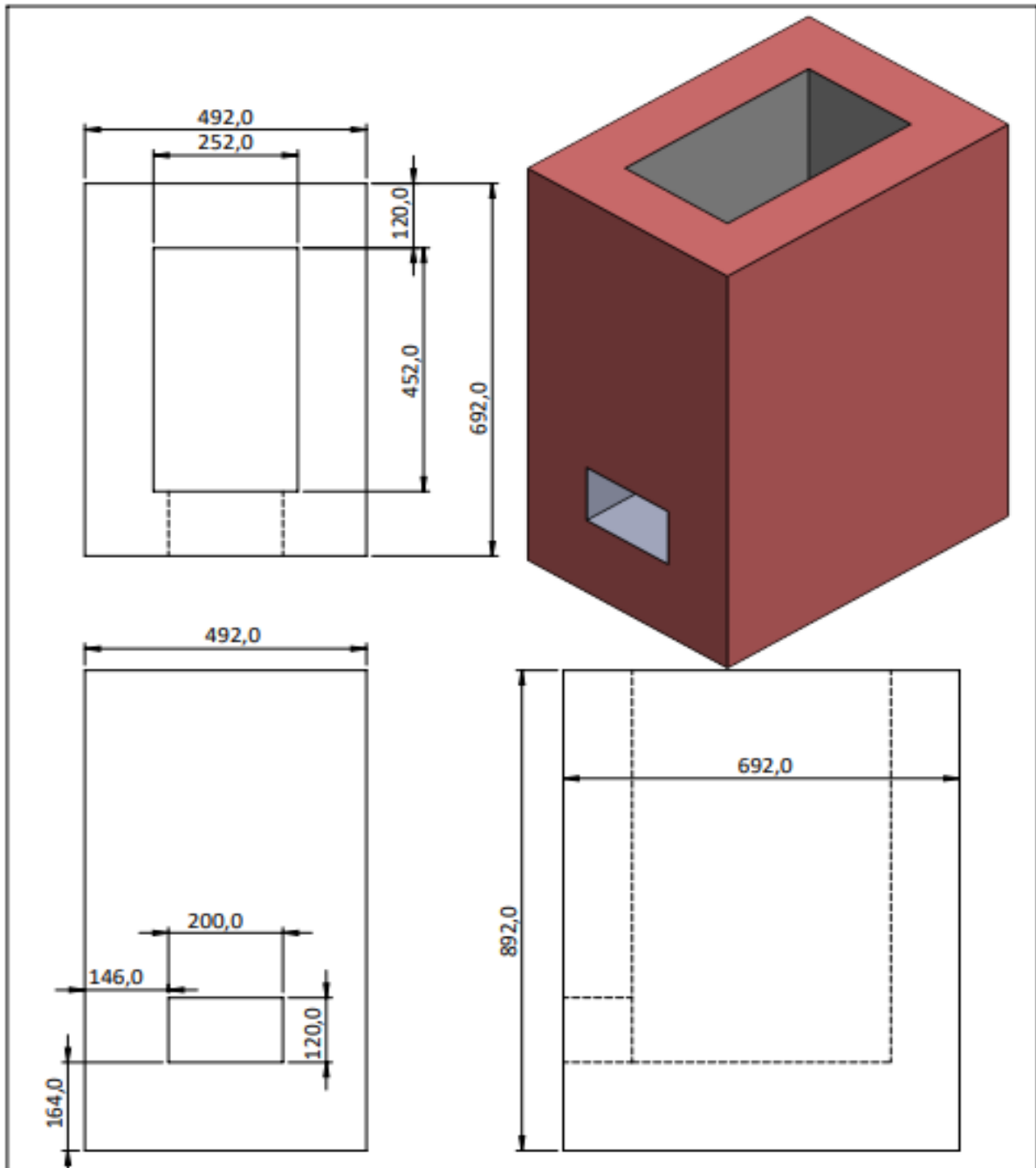

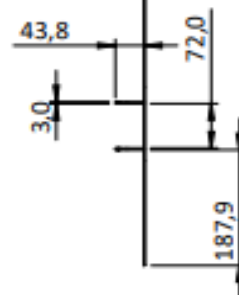
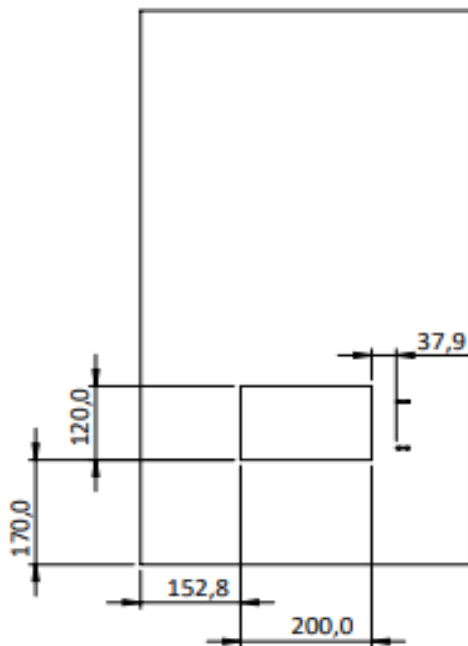
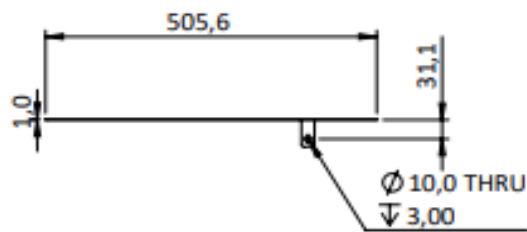

JML	NAMA BAGIAN						BAHAN	UKURAN JADI	UKURAN KASAR	NO. ID	KETERANGAN
>	0	6	30	120	400	1000	PENGKERJAAN LANJUT	NO. ORDER	PROYEKSI		
<	6	30	120	400	1000	2000					
TOL	±0.1	±0.2	±0.3	±0.5	±0.8	±1.2					
LAPISAN BATA SEMEN									SKALA	DIGAMBAR	AKBAR
									1:10	DIPERIKSA	
POLITEKNIK NEGERI CILACAP									FORMAT	NO. GAMBAR	
									A4	ILM/09	

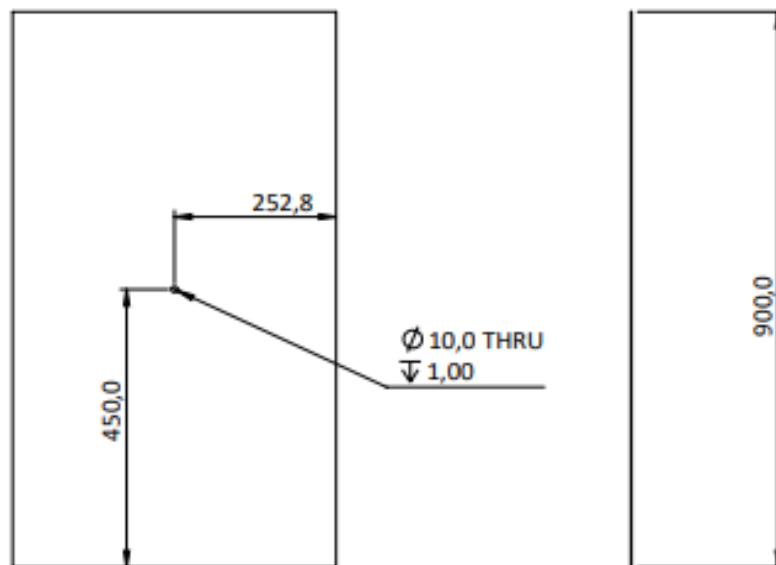
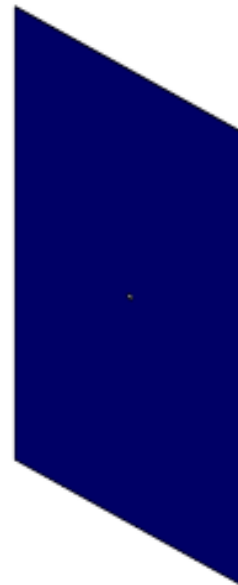
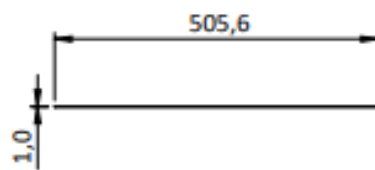

JML	NAMA BAGIAN						BAHAN	UKURAN JADI	UKURAN KASAR	NO. ID	KETERANGAN
>	0	6	30	120	400	1000	Pengerjaan Lanjut	NO. ORDER		PROYEKSI AKBAR	
<	6	30	120	400	1000	2000					
TOL	±0.1	±0.2	±0.3	±0.5	±0.8	±1.2					
CASING DEPAN									SKALA	DIGAMBAR	
									1:10	DIPERIKSA	
										DISAHKAN	
POLITEKNIK NEGERI CILACAP									FORMAT	NO. GAMBAR	
									A4	ILM/10	

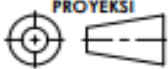

JML	NAMA BAGIAN						BAHAN	UKURAN JADI	UKURAN KASAR	NO. ID	KETERANGAN
>	0	6	30	120	400	1000	PENGKERJAAN LANJUT	NO. ORDER		PROYEKSI 	
<	6	30	120	400	1000	2000					
TOL	±0.1	±0.2	±0.3	±0.5	±0.8	±1.2					
CASING BELAKANG									SKALA	DIGAMBAR	AKBAR
									1:10	DIPERIKSA	
										DISAHKAN	
 POLITEKNIK NEGERI CILACAP									FORMAT	NO. GAMBAR	
									A4	ILM/11	

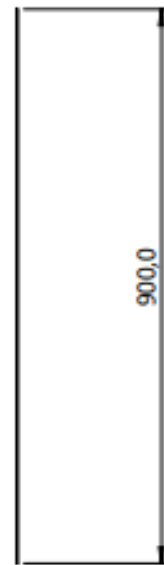
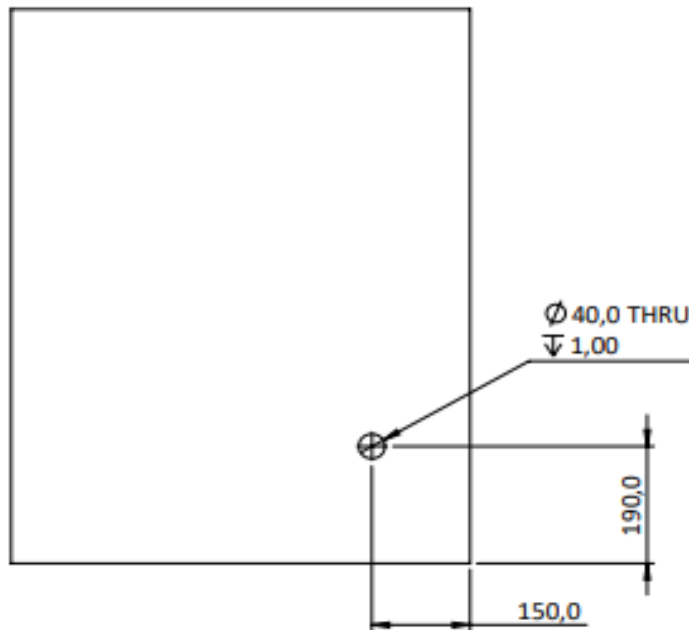
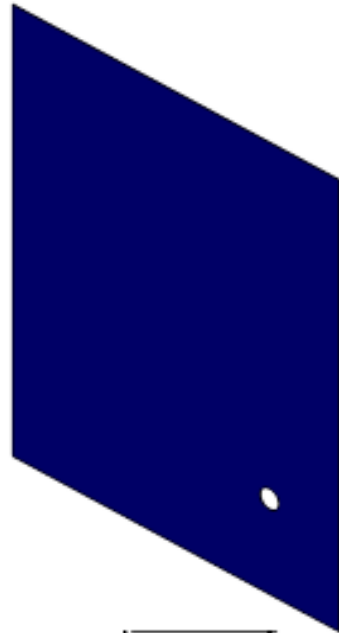
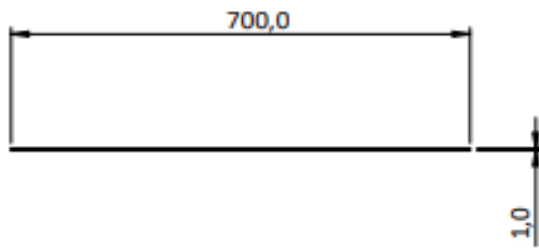

JML	NAMA BAGIAN						BAHAN	UKURAN JADI	UKURAN KASAR	NO. ID	KETERANGAN
>	0	6	30	120	400	1000	Pengerjaan Lanjut	NO. ORDER		PROYEKSI AKBAR	
<	6	30	120	400	1000	2000					
TOL	±0.1	±0.2	±0.3	±0.5	±0.8	±1.2					
CASING SAMPING KIRI									SKALA 1:10	DIGAMBAR DIPERIKSA DISAHKAN	AKBAR
POLITEKNIK NEGERI CILACAP									FORMAT A4	NO. GAMBAR ILM/12	

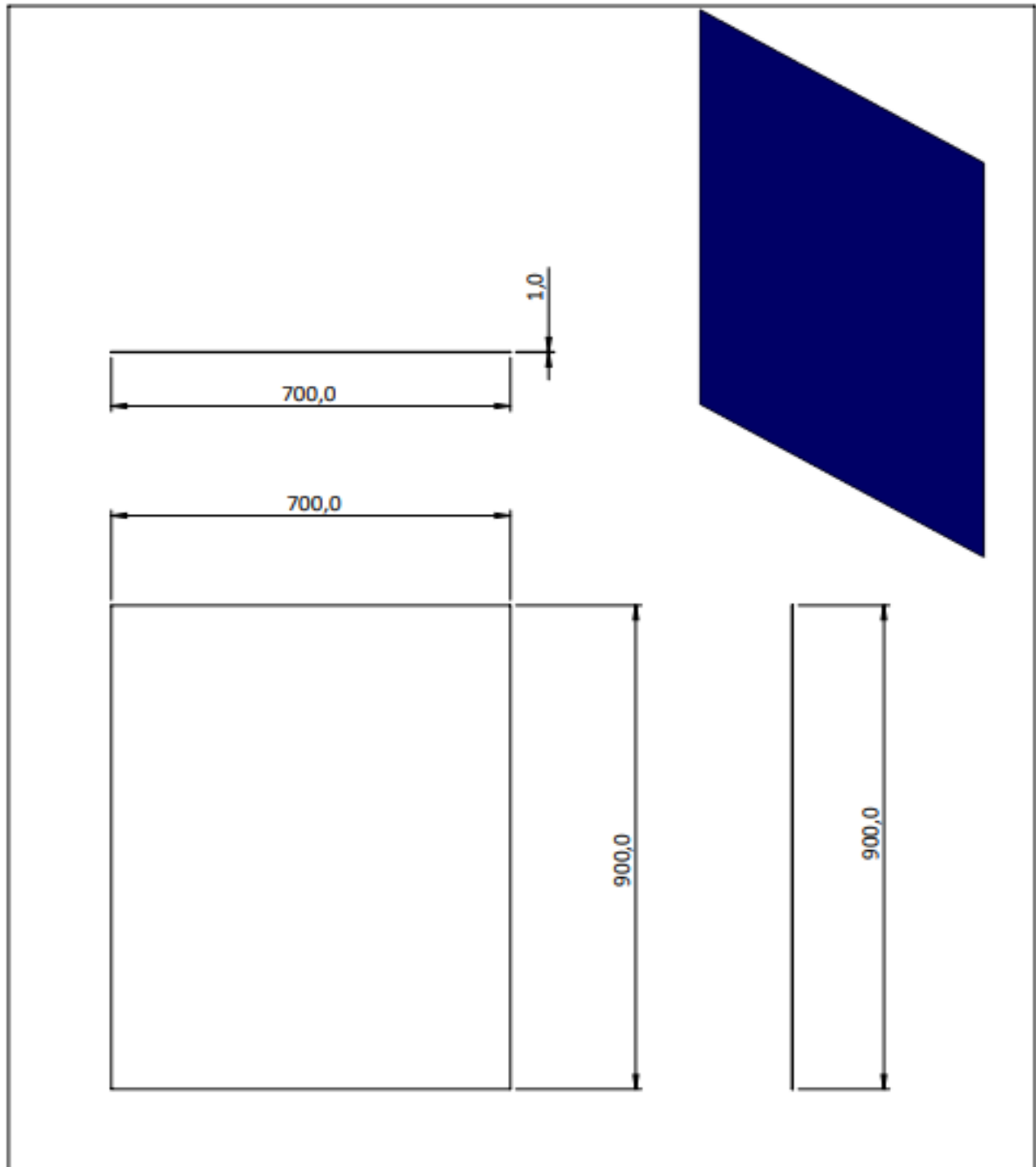

JML	NAMA BAGIAN						BAHAN	UKURAN JADI	UKURAN KASAR	NO. ID	KETERANGAN
>	0	6	30	120	400	1000	Pengerjaan Lanjut	NO. ORDER		PROYEKSI 	
<	6	30	120	400	1000	2000					
TOL	±0.1	±0.2	±0.3	±0.5	±0.8	±1.2					
CASING SAMPING KANAN									SKALA	DIGAMBAR	AKBAR
									1:10	DIPERIKSA	
										DISAHKAN	
POLITEKNIK NEGERI CILACAP									FORMAT	NO. GAMBAR	
									A4	ILM/13	

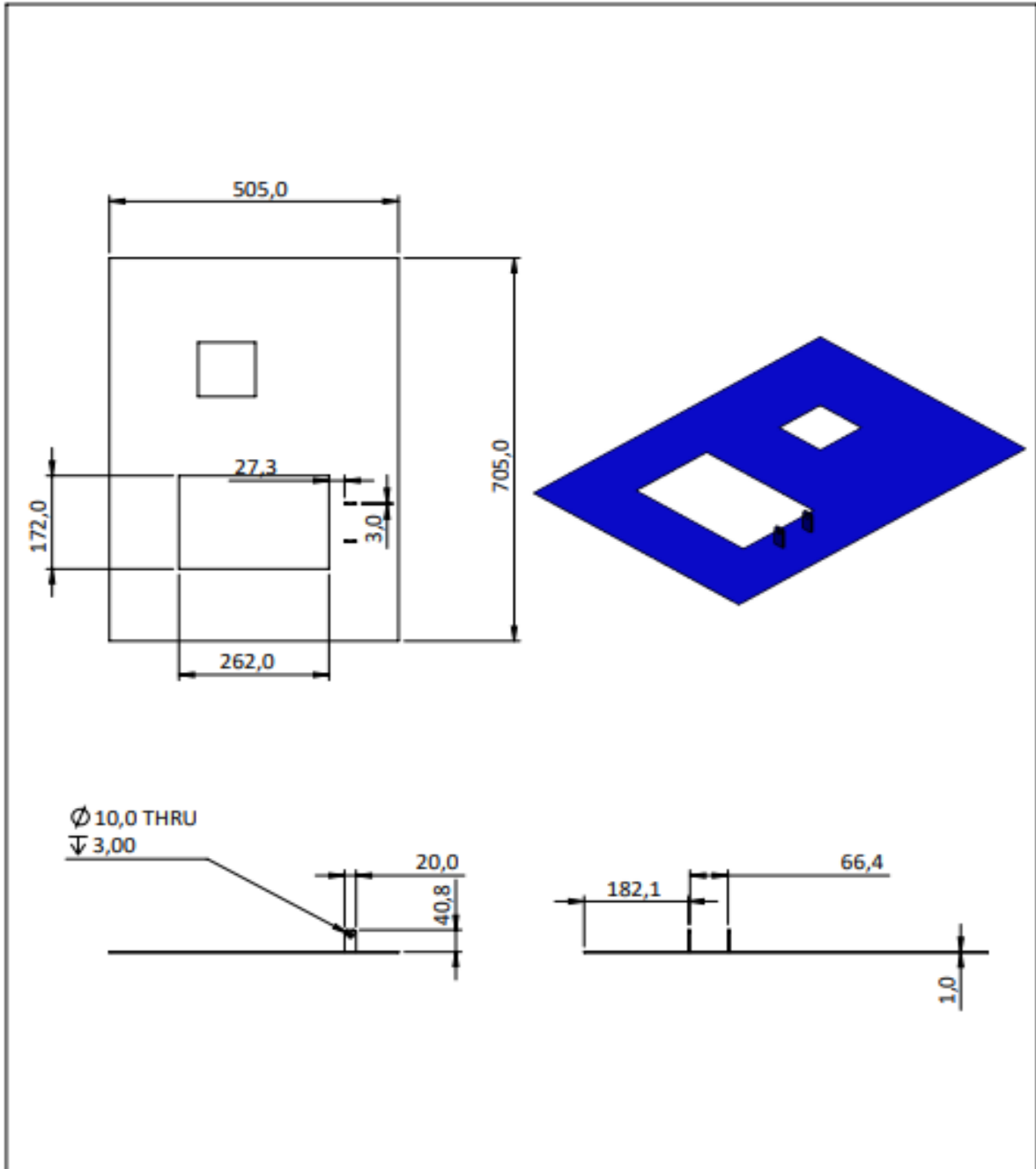

JML	NAMA BAGIAN						BAHAN	UKURAN JADI	UKURAN KASAR	NO. ID	KETERANGAN
>	0	6	30	120	400	1000	PENGERJAAN LANJUT	NO. ORDER			
<	6	30	120	400	1000	2000					
TOL	±0.1	±0.2	±0.3	±0.5	±0.8	±1.2					
CASING ATAS									SKALA	DIGAMBAR	AKBAR
									1:10	DIPERIKSA	
										DISAHKAN	
POLITEKNIK NEGERI CILACAP									FORMAT	NO. GAMBAR	
									A4	ILM/14	

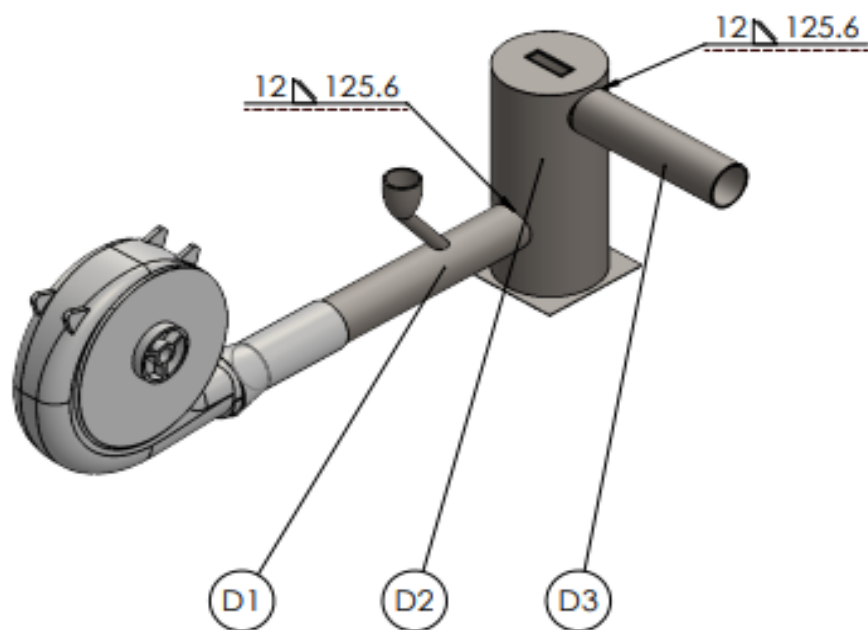

1	PIPA BLOWER	MILD STEEL	LIHAT DETAIL	-	D1	-
1	TABUNG BURNER	MILD STEEL	LIHAT DETAIL	-	D2	-
1	PIPA BURNER	MILD STEEL	LIHAT DETAIL	-	D3	-
JML	NAMA BAGIAN	BAHAN	UKURAN JADI	UKURAN KASAR	NO. ID	KETERANGAN
>	0	6	30	120	400	1000
<	6	30	120	400	1000	2000
TOL	±0.1	±0.2	±0.3	±0.5	±0.8	±1.2
PENGERJAAN LANJUT				NO. ORDER		PROYEKSI
ASSY BURNER				1:5	DIPERIKSA	
					DISAHKAN	
POLITEKNIK NEGERI CILACAP				FORMAT A4	NO. GAMBAR ILM/15	

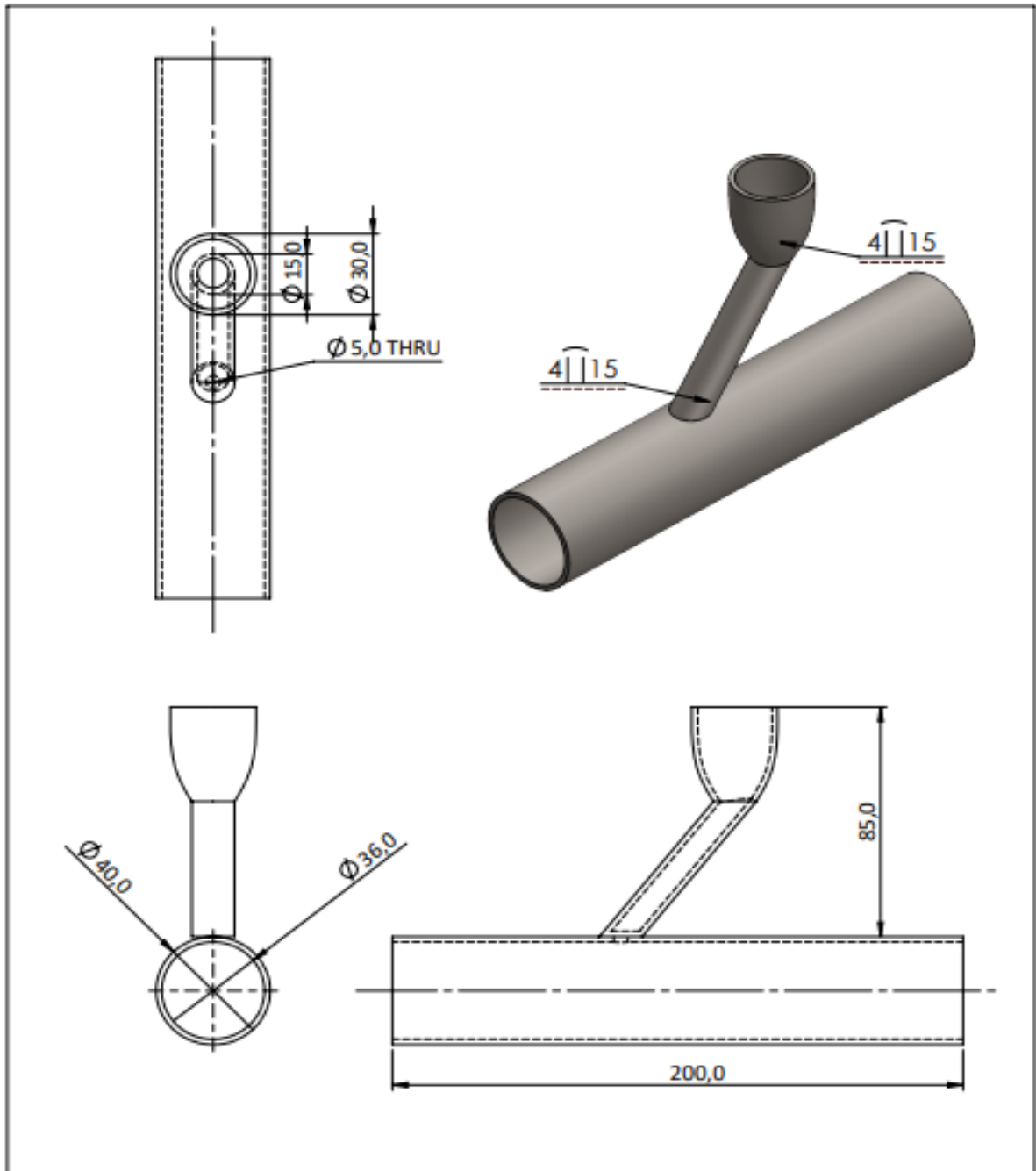

JML	NAMA BAGIAN						BAHAN	UKURAN JADI	UKURAN KASAR	NO. ID	KETERANGAN
>	0	6	30	120	400	1000	PENGKERJAAN LANJUT	NO. ORDER		 PROYEKSI	
<	6	30	120	400	1000	2000					
TOL	±0.1	±0.2	±0.3	±0.5	±0.8	±1.2					
PIPA BLOWER									SKALA	DIGAMBAR	AKBAR
									1:2	DIPERIKSA	
										DISAHKAN	
POLITEKNIK NEGERI CILACAP									FORMAT	NO. GAMBAR	
									A4	ILM/16	

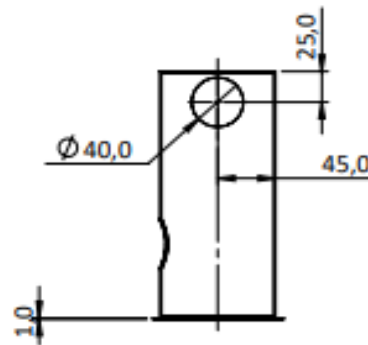
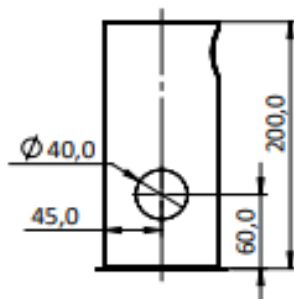
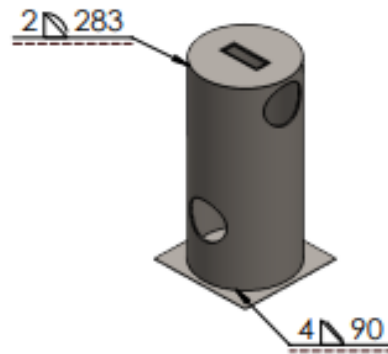
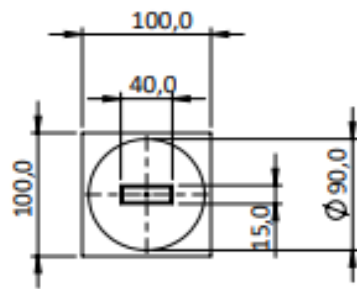

JML	NAMA BAGIAN						BAHAN	UKURAN JADI	UKURAN KASAR	NO. ID	KETERANGAN
>	0	6	30	120	400	1000	PENGKERJAAN LANJUT	NO. ORDER		PROYEKSI	
<	6	30	120	400	1000	2000					
TOL	±0.1	±0.2	±0.3	±0.5	±0.8	±1.2					
TABUNG BURNER									SKALA	DIGAMBAR	AKBAR
									1:5	DIPERIKSA	
										DISAHKAN	
POLITEKNIK NEGERI CILACAP									FORMAT	NO. GAMBAR	
									A4	ILM/17	

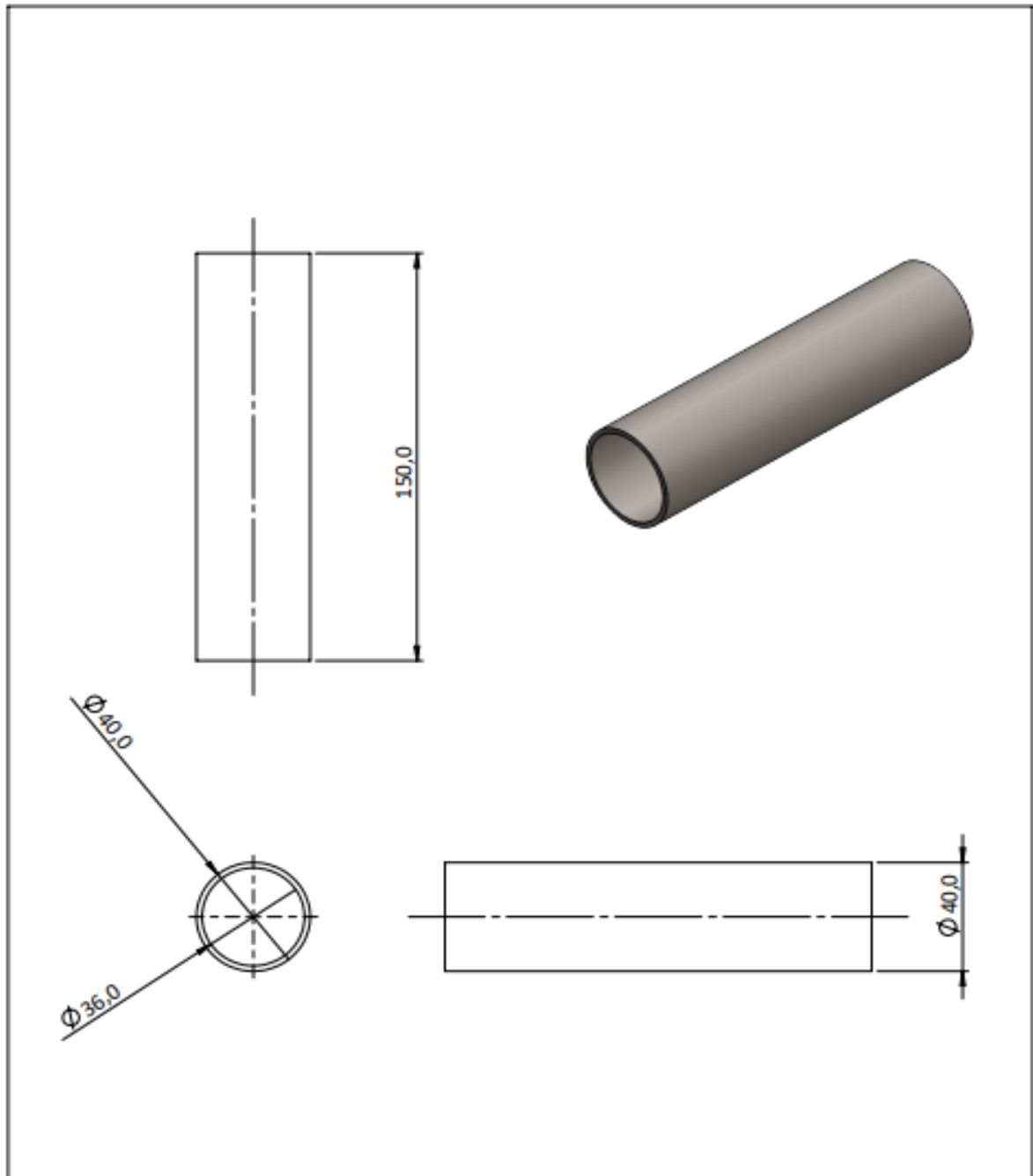

JML	NAMA BAGIAN						BAHAN	UKURAN JADI	UKURAN KASAR	NO. ID	KETERANGAN
>	0	6	30	120	400	1000	PENGKERJAAN LANJUT		NO. ORDER	PROYEKSI	
<	6	30	120	400	1000	2000					
TOL	±0.1	±0.2	±0.3	±0.5	±0.8	±1.2					
PIPA BURNER									SKALA	DIGAMBAR	AKBAR
									1:2	DIPERIKSA	
										DISAHKAN	
POLITEKNIK NEGERI CILACAP									FORMAT	NO. GAMBAR	
									A4	ILM/18	

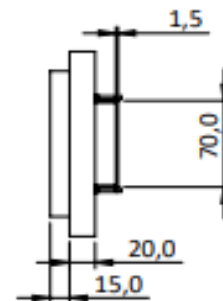
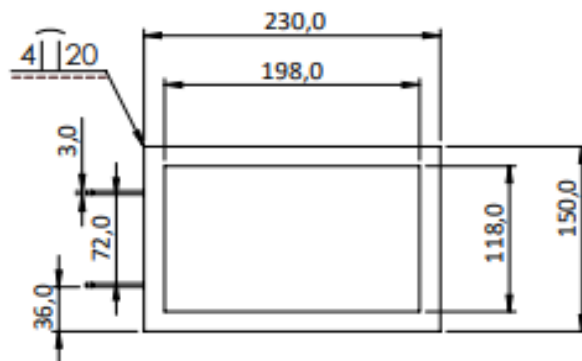
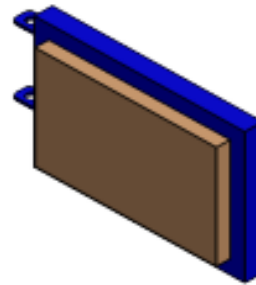
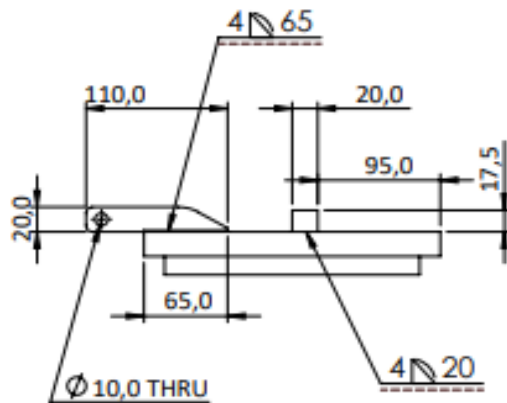

JML	NAMA BAGIAN						BAHAN	UKURAN JADI	UKURAN KASAR	NO. ID	KETERANGAN
>	0	6	30	120	400	1000	PENGERJAAN LANJUT	NO. ORDER	PROYEKSI		
<	6	30	120	400	1000	2000					
TOL	±0.1	±0.2	±0.3	±0.5	±0.8	±1.2					
PINTU BAWAH									SKALA	DIGAMBAR	AKBAR
									1:5	DIPERIKSA	
										DISAHKAN	
POLITEKNIK NEGERI CILACAP									FORMAT A4	NO. GAMBAR ILM/19	

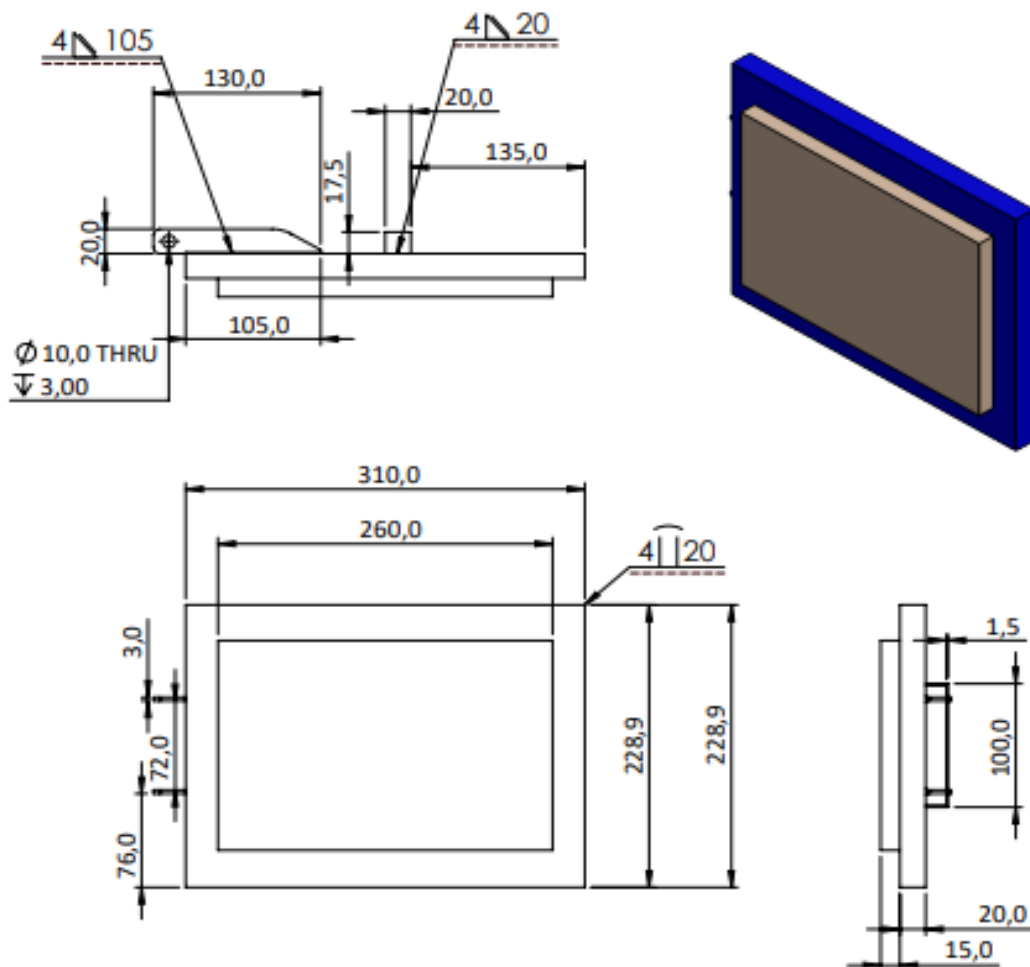

JML	NAMA BAGIAN						BAHAN	UKURAN JADI	UKURAN KASAR	NO. ID	KETERANGAN
>	0	6	30	120	400	1000	PENGERJAAN LANJUT	NO. ORDER		 PROYEKSI	
<	6	30	120	400	1000	2000					
TOL	±0.1	±0.2	±0.3	±0.5	±0.8	±1.2					
PINTU ATAS									SKALA	DIGAMBAR	AKBAR
									1:5	DIPERIKSA	
										DISAHKAN	
POLITEKNIK NEGERI CILACAP									FORMAT	NO. GAMBAR	
									A4	ILM/20	

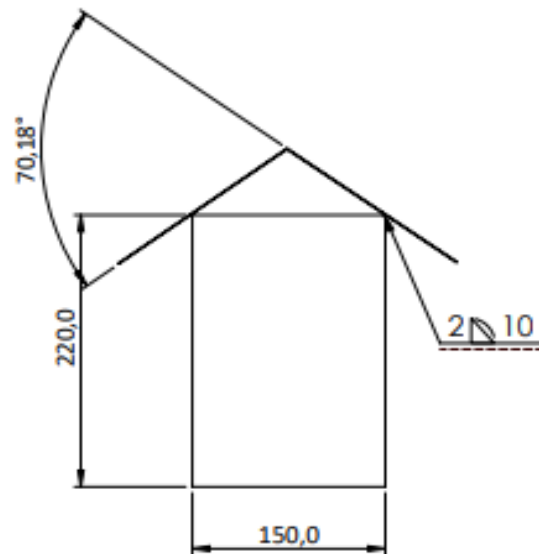
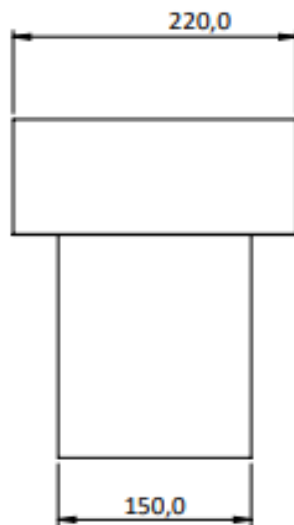
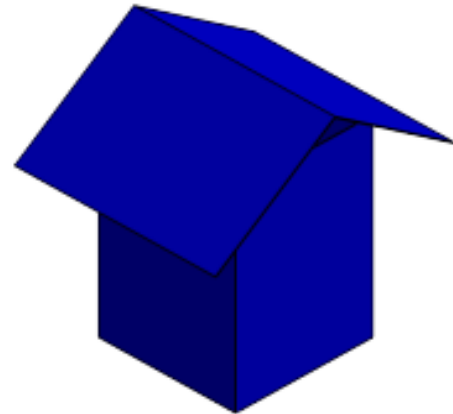
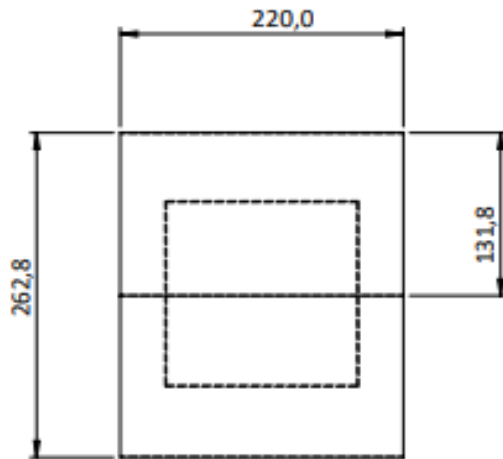

JML	NAMA BAGIAN						BAHAN	UKURAN JADI	UKURAN KASAR	NO. ID	KETERANGAN
>	0	6	30	120	400	1000	PENGERJAAN LANJUT	NO. ORDER	PROYEKSI		
<	6	30	120	400	1000	2000					
TOL	±0.1	±0.2	±0.3	±0.5	±0.8	±1.2					
CEROBONG ASAP									SKALA	DIGAMBAR	AKBAR
									1:5	DIPERIKSA	
										DISAHKAN	
 POLITEKNIK NEGERI CILACAP									FORMAT	NO. GAMBAR	
									A4	ILM/21	

LAMPIRAN 2
(BIODATA PENULIS)

BIODATA PENULIS



Nama : Akbar Bakti Purnomo
Tempat, tanggal lahir : Cilacap, 14 Februari 2002
Alamat :Jl. Salam Rt 03 / Rw 06, kel. Gumilir, Kec. Cilacap utara,
Cilacap, Jawa Tengah
Telephone/HP : 081327460212
e-mail : akbarbakti2002@gmail.com
Hobi : touring naik motor
Motto : Hidup yang tidak dipertaruhkan, tidak akan pernah
dimenangkan.

Riwayat Pendidikan:

1. SMP Negeri 4 Cilacap : Tahun 2014-2017
2. SMK Negeri 2 Cilacap : Tahun 2017-2020