

| JML                              | NAMA BAGIAN |      |      |      |      |      | BAHAN             | UKURAN JADI | UKURAN KASAR | NO. ID       | KETERANGAN |
|----------------------------------|-------------|------|------|------|------|------|-------------------|-------------|--------------|--------------|------------|
| >                                | 0           | 6    | 30   | 120  | 400  | 1000 | Pengerjaan Lanjut | NO. ORDER   |              | <br>PROYEKSI |            |
| <                                | 6           | 30   | 120  | 400  | 1000 | 2000 |                   |             |              |              |            |
| TOL                              | ±0.1        | ±0.2 | ±0.3 | ±0.5 | ±0.8 | ±1.2 |                   |             |              |              |            |
| casing samping kiri              |             |      |      |      |      |      |                   |             | SKALA        | DIGAMBAR     |            |
|                                  |             |      |      |      |      |      |                   |             | 1:10         | DIPERIKSA    |            |
|                                  |             |      |      |      |      |      |                   |             |              | DISAHKAN     |            |
|                                  |             |      |      |      |      |      |                   |             | FORMAT       | NO. GAMBAR   |            |
| <b>POLITEKNIK NEGERI CILACAP</b> |             |      |      |      |      |      |                   |             | <b>A4</b>    |              |            |

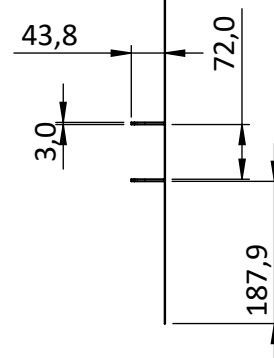

| JML                              | NAMA BAGIAN |      |      |      |      |      | BAHAN             | UKURAN JADI | UKURAN KASAR | NO. ID     | KETERANGAN |  |
|----------------------------------|-------------|------|------|------|------|------|-------------------|-------------|--------------|------------|------------|--|
| >                                | 0           | 6    | 30   | 120  | 400  | 1000 | Pengerjaan Lanjut |             | NO. ORDER    |            |            |  |
| <                                | 6           | 30   | 120  | 400  | 1000 | 2000 |                   |             |              |            |            |  |
| TOL                              | ±0.1        | ±0.2 | ±0.3 | ±0.5 | ±0.8 | ±1.2 |                   |             |              |            |            |  |
| casing depan                     |             |      |      |      |      |      |                   |             | SKALA        | DIGAMBAR   |            |  |
|                                  |             |      |      |      |      |      |                   |             | 1:10         | DIPERIKSA  |            |  |
|                                  |             |      |      |      |      |      |                   |             |              | DISAHKAN   |            |  |
|                                  |             |      |      |      |      |      |                   |             |              |            |            |  |
| <b>POLITEKNIK NEGERI CILACAP</b> |             |      |      |      |      |      |                   |             | FORMAT       | NO. GAMBAR |            |  |
|                                  |             |      |      |      |      |      |                   |             | <b>A4</b>    |            |            |  |

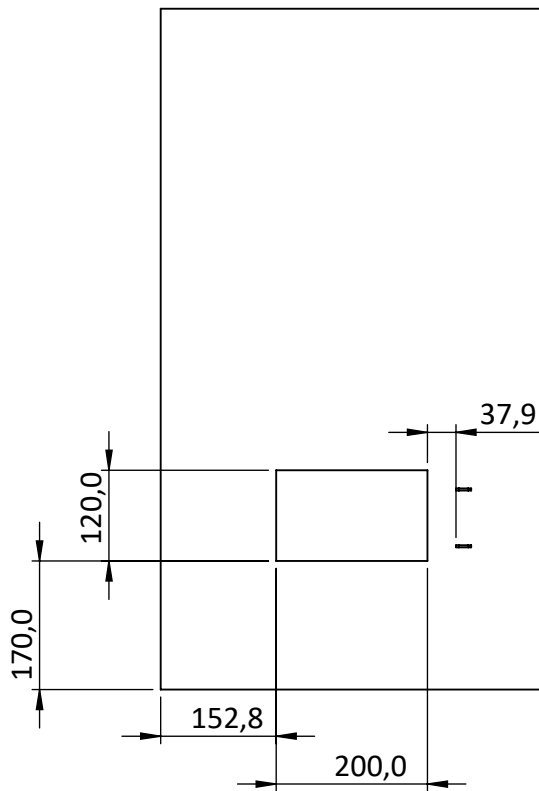
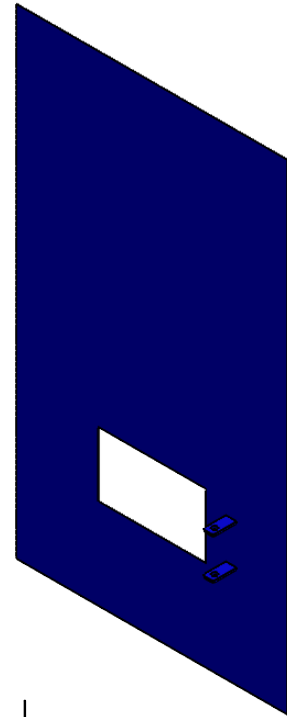
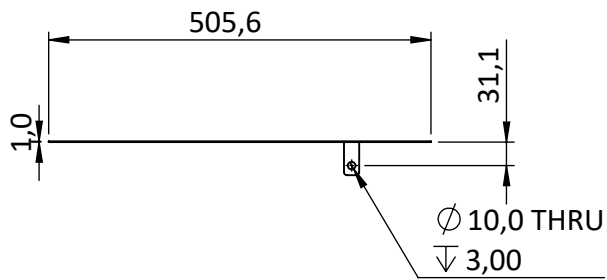
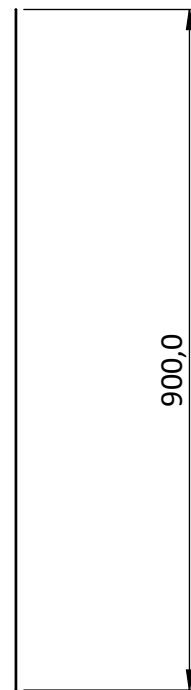
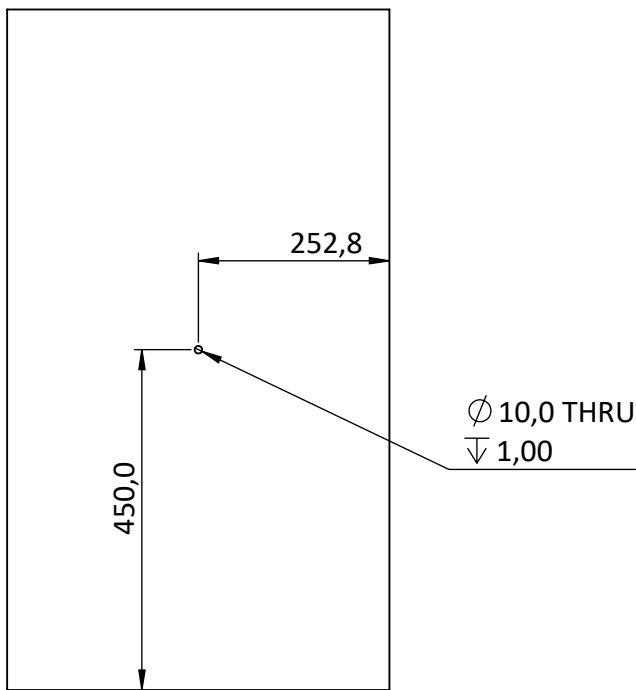
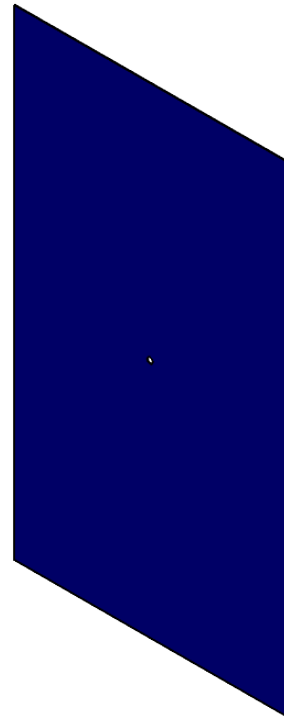
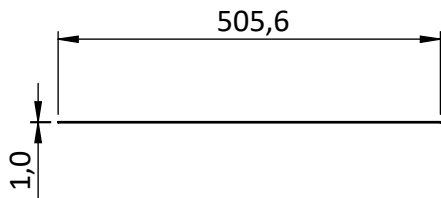

| JML                              | NAMA BAGIAN |           |           |           |           |           | BAHAN             | UKURAN JADI | UKURAN KASAR        | NO. ID     | KETERANGAN |
|----------------------------------|-------------|-----------|-----------|-----------|-----------|-----------|-------------------|-------------|---------------------|------------|------------|
| >                                | 0           | 6         | 30        | 120       | 400       | 1000      | Pengerjaan Lanjut |             | NO. ORDER           |            |            |
| <                                | 6           | 30        | 120       | 400       | 1000      | 2000      |                   |             |                     |            |            |
| TOL                              | $\pm 0.1$   | $\pm 0.2$ | $\pm 0.3$ | $\pm 0.5$ | $\pm 0.8$ | $\pm 1.2$ |                   |             |                     |            |            |
| casing belakang                  |             |           |           |           |           |           |                   |             | SKALA<br>1:10       | DIGAMBAR   |            |
|                                  |             |           |           |           |           |           |                   |             | DIPERIKSA           |            |            |
|                                  |             |           |           |           |           |           |                   |             | DISAHKAN            |            |            |
| <b>POLITEKNIK NEGERI CILACAP</b> |             |           |           |           |           |           |                   |             | FORMAT<br><b>A4</b> | NO. GAMBAR |            |

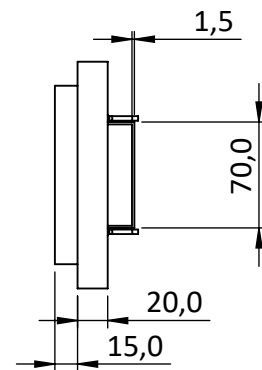
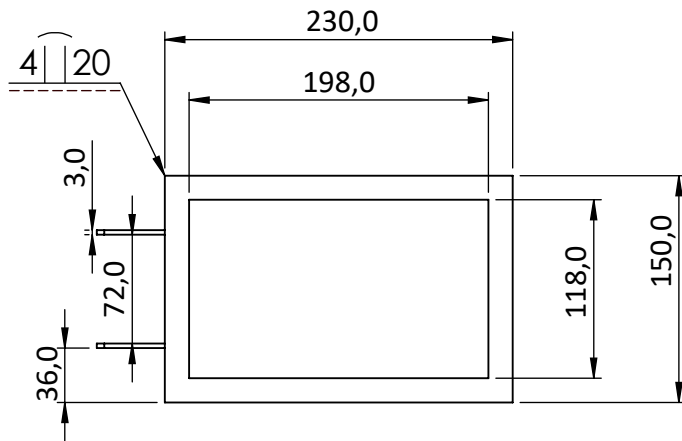
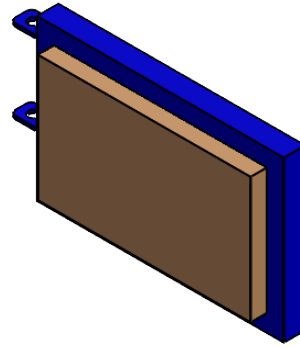
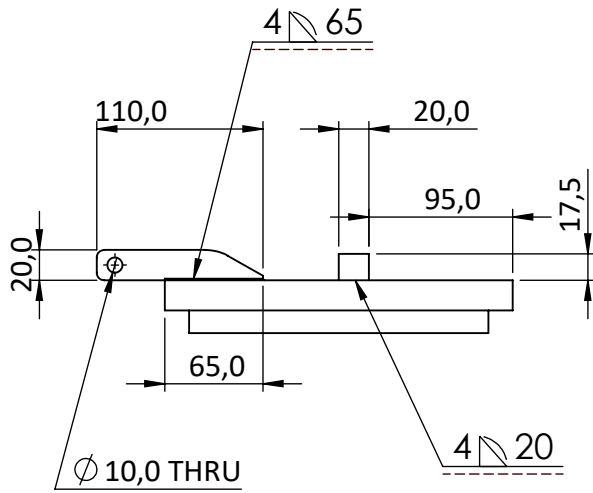

| JML                              | NAMA BAGIAN |      |      |      |      |      | BAHAN             | UKURAN JADI | UKURAN KASAR | NO. ID     | KETERANGAN |
|----------------------------------|-------------|------|------|------|------|------|-------------------|-------------|--------------|------------|------------|
| >                                | 0           | 6    | 30   | 120  | 400  | 1000 | Pengerjaan Lanjut |             | NO. ORDER    |            |            |
| <                                | 6           | 30   | 120  | 400  | 1000 | 2000 |                   |             |              |            |            |
| TOL                              | ±0.1        | ±0.2 | ±0.3 | ±0.5 | ±0.8 | ±1.2 |                   |             |              |            |            |
| pintu incinerator bawah          |             |      |      |      |      |      |                   |             | SKALA        | DIGAMBAR   |            |
|                                  |             |      |      |      |      |      |                   |             | 1:5          | DIPERIKSA  |            |
|                                  |             |      |      |      |      |      |                   |             |              | DISAHKAN   |            |
| <b>POLITEKNIK NEGERI CILACAP</b> |             |      |      |      |      |      |                   |             | FORMAT       | NO. GAMBAR |            |
|                                  |             |      |      |      |      |      |                   |             | <b>A4</b>    |            |            |

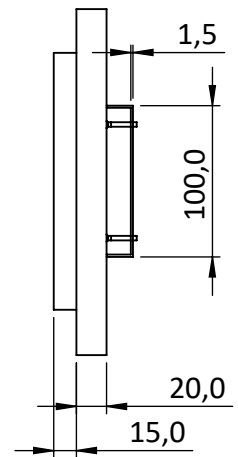
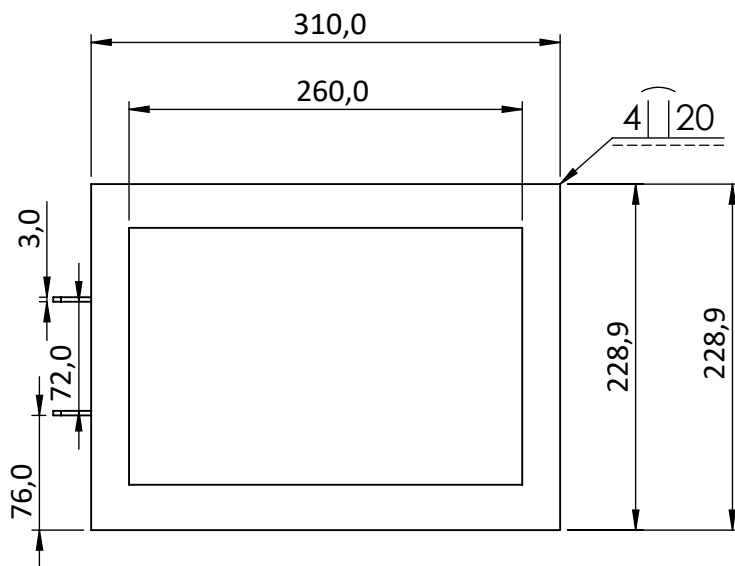
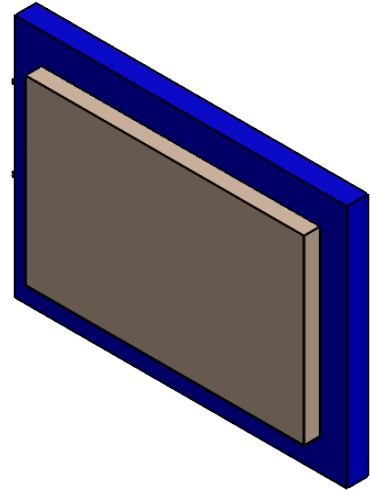
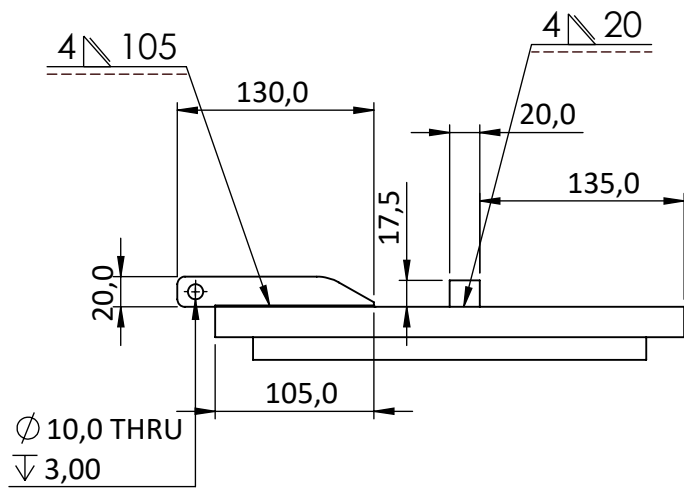

| JML                              | NAMA BAGIAN |      |      |      |      |      | BAHAN             | UKURAN JADI | UKURAN KASAR | NO. ID       | KETERANGAN |
|----------------------------------|-------------|------|------|------|------|------|-------------------|-------------|--------------|--------------|------------|
| >                                | 0           | 6    | 30   | 120  | 400  | 1000 | Pengerjaan Lanjut | NO. ORDER   |              | PROYEKSI<br> |            |
| <                                | 6           | 30   | 120  | 400  | 1000 | 2000 |                   |             |              |              |            |
| TOL                              | ±0.1        | ±0.2 | ±0.3 | ±0.5 | ±0.8 | ±1.2 |                   |             |              |              |            |
| pintu incinerator atas           |             |      |      |      |      |      |                   |             | SKALA        | DIGAMBAR     |            |
|                                  |             |      |      |      |      |      |                   |             | 1:5          | DIPERIKSA    |            |
|                                  |             |      |      |      |      |      |                   |             |              | DISAHKAN     |            |
| <b>POLITEKNIK NEGERI CILACAP</b> |             |      |      |      |      |      |                   |             | FORMAT       | NO. GAMBAR   |            |
|                                  |             |      |      |      |      |      |                   |             | <b>A4</b>    |              |            |

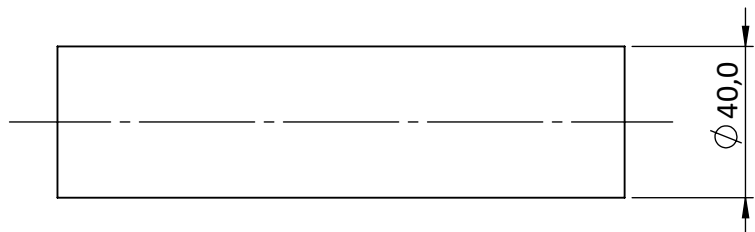
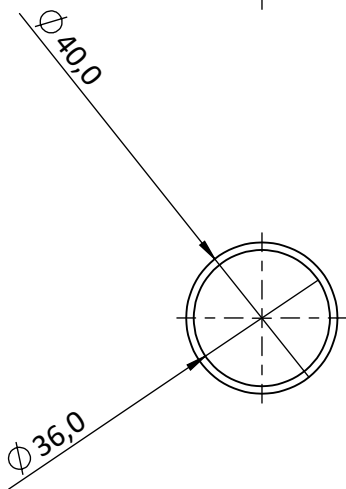
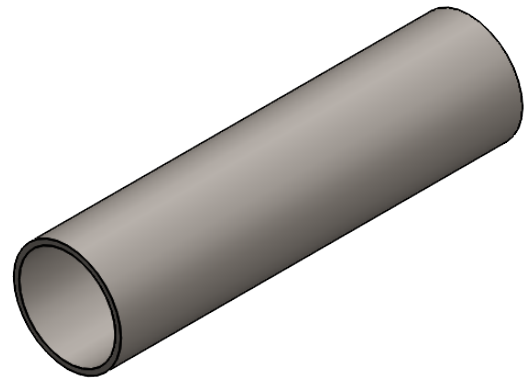
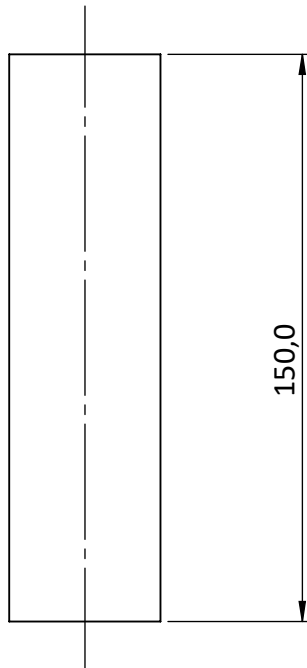

| JML  | NAMA BAGIAN |           |           |           |           |           | BAHAN             | UKURAN JADI | UKURAN KASAR        | NO. ID     | KETERANGAN |
|--|-------------|-----------|-----------|-----------|-----------|-----------|-------------------|-------------|---------------------|------------|------------|
| >  | 0           | 6         | 30        | 120       | 400       | 1000      | Pengerjaan Lanjut |             | NO. ORDER           | PROYEKSI   |            |
| <  | 6           | 30        | 120       | 400       | 1000      | 2000      |                   |             |                     |            |            |
| TOL  | $\pm 0.1$   | $\pm 0.2$ | $\pm 0.3$ | $\pm 0.5$ | $\pm 0.8$ | $\pm 1.2$ |                   |             |                     |            |            |
| <p style="text-align: center;">pipa burner</p> |             |           |           |           |           |           |                   |             | SKALA<br>1:2        | DIGAMBAR   |            |
|  |             |           |           |           |           |           |                   |             | DIPERIKSA           |            |            |
|  |             |           |           |           |           |           |                   |             | DISAHKAN            |            |            |
| <b>POLITEKNIK NEGERI CILACAP</b>               |             |           |           |           |           |           |                   |             | FORMAT<br><b>A4</b> | NO. GAMBAR |            |

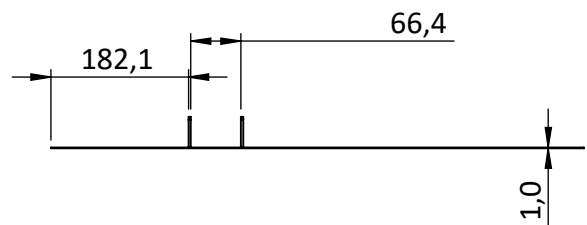
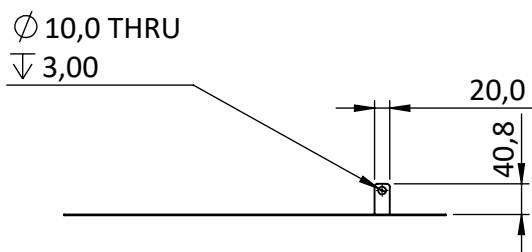
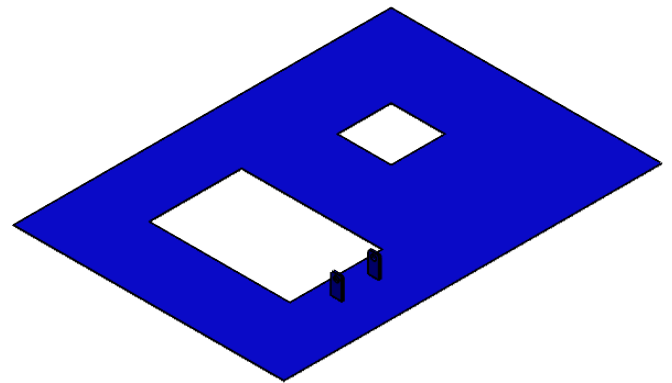
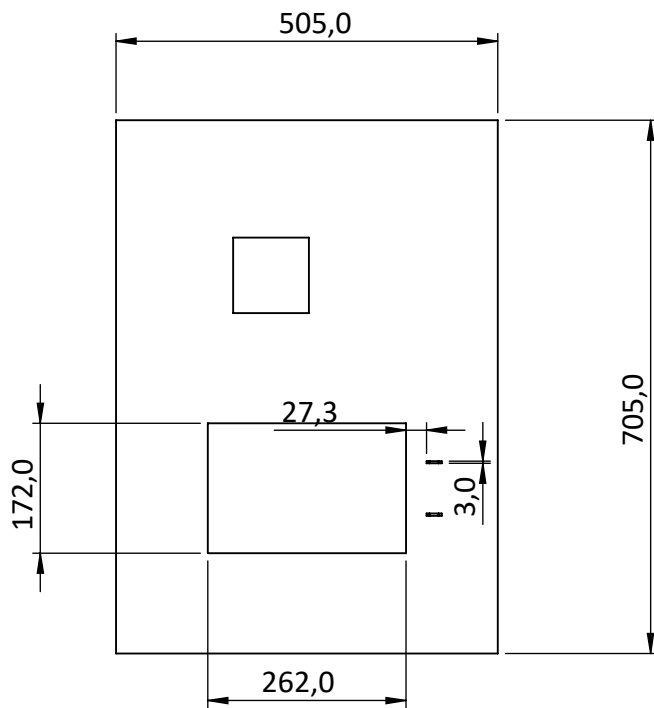

| JML                              | NAMA BAGIAN |      |      |      |      |      | BAHAN             | UKURAN JADI | UKURAN KASAR | NO. ID     | KETERANGAN |  |
|----------------------------------|-------------|------|------|------|------|------|-------------------|-------------|--------------|------------|------------|--|
| >                                | 0           | 6    | 30   | 120  | 400  | 1000 | Pengerjaan Lanjut | NO. ORDER   |              |            |            |  |
| <                                | 6           | 30   | 120  | 400  | 1000 | 2000 |                   |             |              |            |            |  |
| TOL                              | ±0.1        | ±0.2 | ±0.3 | ±0.5 | ±0.8 | ±1.2 |                   |             |              |            |            |  |
| casing atas                      |             |      |      |      |      |      |                   |             | SKALA        | DIGAMBAR   |            |  |
|                                  |             |      |      |      |      |      |                   |             | 1:10         | DIPERIKSA  |            |  |
|                                  |             |      |      |      |      |      |                   |             |              | DISAHKAN   |            |  |
|                                  |             |      |      |      |      |      |                   |             |              |            |            |  |
| <b>POLITEKNIK NEGERI CILACAP</b> |             |      |      |      |      |      |                   |             | FORMAT       | NO. GAMBAR |            |  |
|                                  |             |      |      |      |      |      |                   |             | <b>A4</b>    |            |            |  |

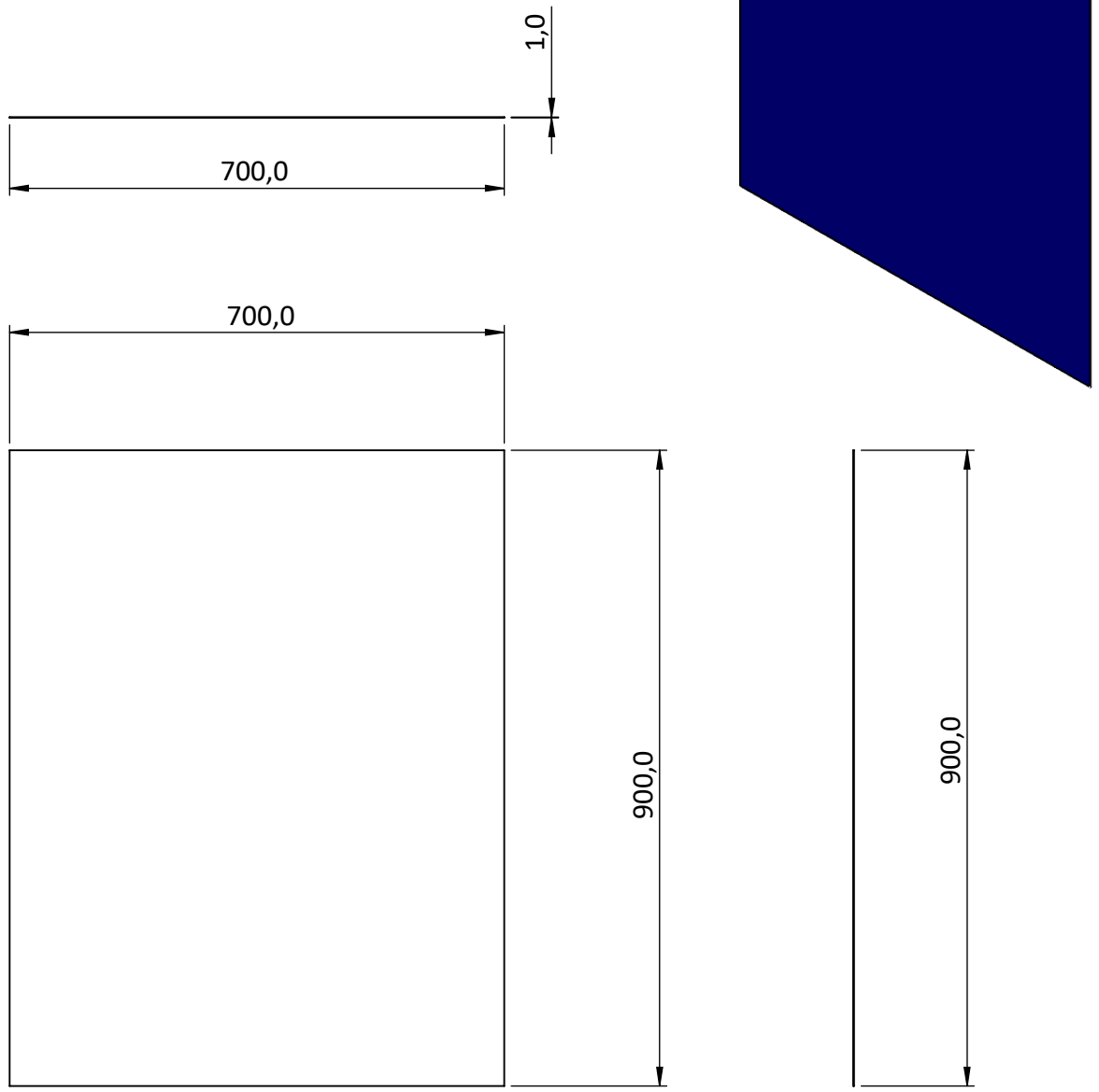

| JML                              | NAMA BAGIAN |      |      |      |      |      | BAHAN             | UKURAN JADI | UKURAN KASAR        | NO. ID       | KETERANGAN |
|----------------------------------|-------------|------|------|------|------|------|-------------------|-------------|---------------------|--------------|------------|
| >                                | 0           | 6    | 30   | 120  | 400  | 1000 | Pengerjaan Lanjut | NO. ORDER   |                     | PROYEKSI<br> |            |
| <                                | 6           | 30   | 120  | 400  | 1000 | 2000 |                   |             |                     |              |            |
| TOL                              | ±0.1        | ±0.2 | ±0.3 | ±0.5 | ±0.8 | ±1.2 |                   |             |                     |              |            |
| casing samping kanan             |             |      |      |      |      |      |                   |             | SKALA<br>1:10       | DIGAMBAR     |            |
|                                  |             |      |      |      |      |      |                   |             | DIPERIKSA           |              |            |
|                                  |             |      |      |      |      |      |                   |             | DISAHKAN            |              |            |
| <b>POLITEKNIK NEGERI CILACAP</b> |             |      |      |      |      |      |                   |             | FORMAT<br><b>A4</b> | NO. GAMBAR   |            |



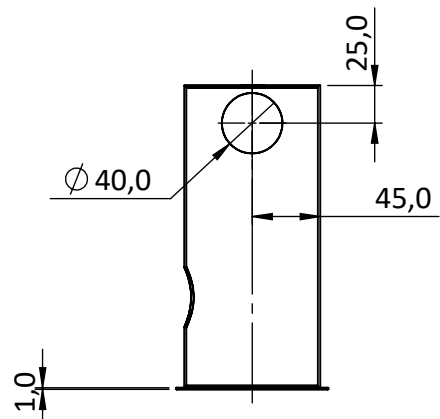
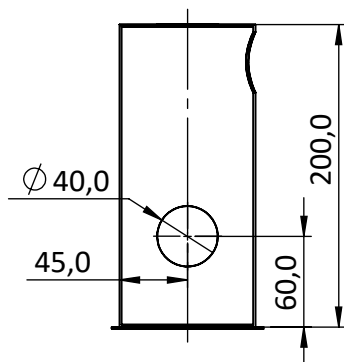
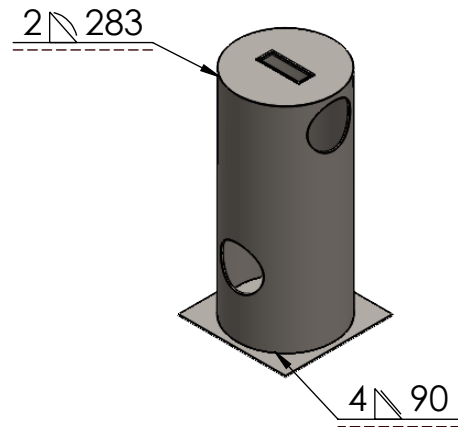
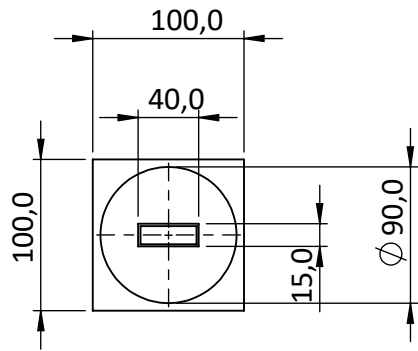

| JML                              | NAMA BAGIAN |      |      |      |      |      | BAHAN             | UKURAN JADI | UKURAN KASAR        | NO. ID     | KETERANGAN |
|----------------------------------|-------------|------|------|------|------|------|-------------------|-------------|---------------------|------------|------------|
| >                                | 0           | 6    | 30   | 120  | 400  | 1000 | Pengerjaan Lanjut |             | NO. ORDER           |            |            |
| <                                | 6           | 30   | 120  | 400  | 1000 | 2000 |                   |             |                     |            |            |
| TOL                              | ±0.1        | ±0.2 | ±0.3 | ±0.5 | ±0.8 | ±1.2 |                   |             |                     |            |            |
| pipa burner                      |             |      |      |      |      |      |                   |             | SKALA<br>1:5        | DIGAMBAR   |            |
|                                  |             |      |      |      |      |      |                   |             | DIPERIKSA           |            |            |
|                                  |             |      |      |      |      |      |                   |             | DISAHKAN            |            |            |
| <b>POLITEKNIK NEGERI CILACAP</b> |             |      |      |      |      |      |                   |             | FORMAT<br><b>A4</b> | NO. GAMBAR |            |

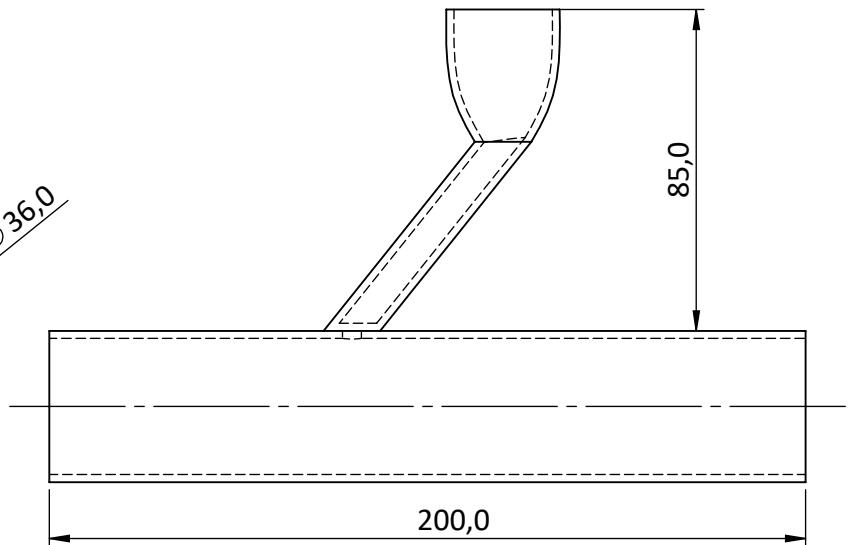
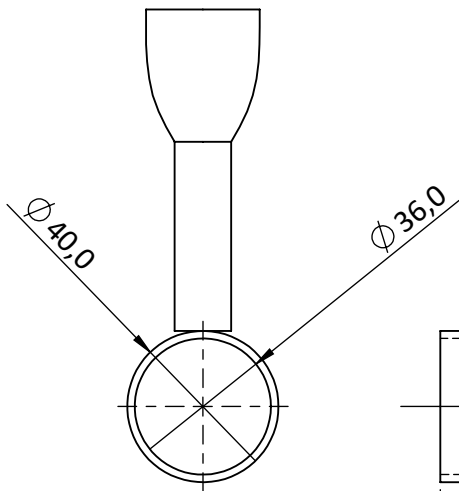
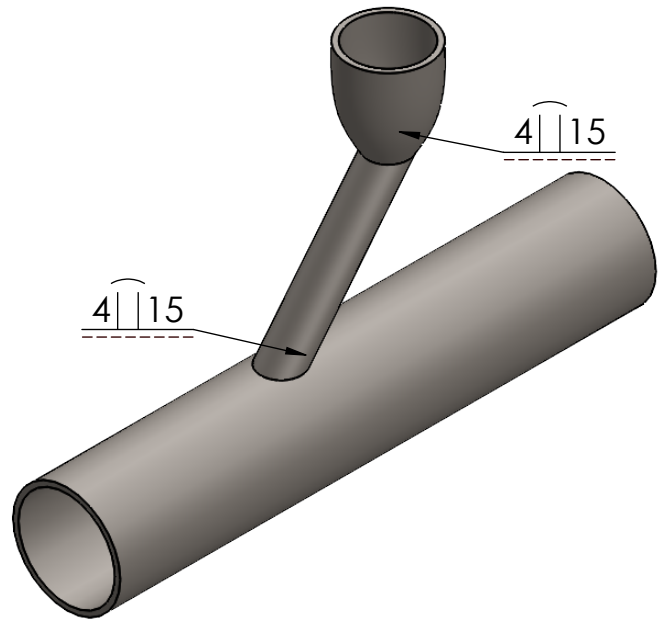
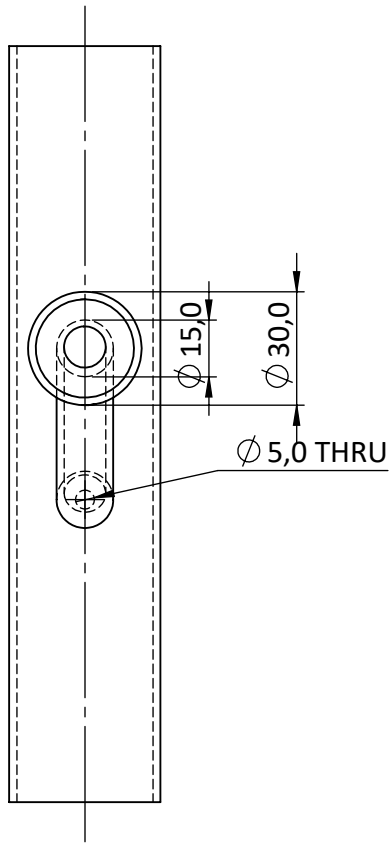

| JML                              | NAMA BAGIAN |      |      |      |      |      | BAHAN             | UKURAN JADI | UKURAN KASAR        | NO. ID     | KETERANGAN |
|----------------------------------|-------------|------|------|------|------|------|-------------------|-------------|---------------------|------------|------------|
| >                                | 0           | 6    | 30   | 120  | 400  | 1000 | Pengerjaan Lanjut | NO. ORDER   |                     |            |            |
| <                                | 6           | 30   | 120  | 400  | 1000 | 2000 |                   |             |                     |            |            |
| TOL                              | ±0.1        | ±0.2 | ±0.3 | ±0.5 | ±0.8 | ±1.2 |                   |             |                     |            |            |
| pipa blower                      |             |      |      |      |      |      |                   |             | SKALA<br>1:2        | DIGAMBAR   |            |
|                                  |             |      |      |      |      |      |                   |             | DIPERIKSA           |            |            |
|                                  |             |      |      |      |      |      |                   |             | DISAHKAN            |            |            |
| <b>POLITEKNIK NEGERI CILACAP</b> |             |      |      |      |      |      |                   |             | FORMAT<br><b>A4</b> | NO. GAMBAR |            |

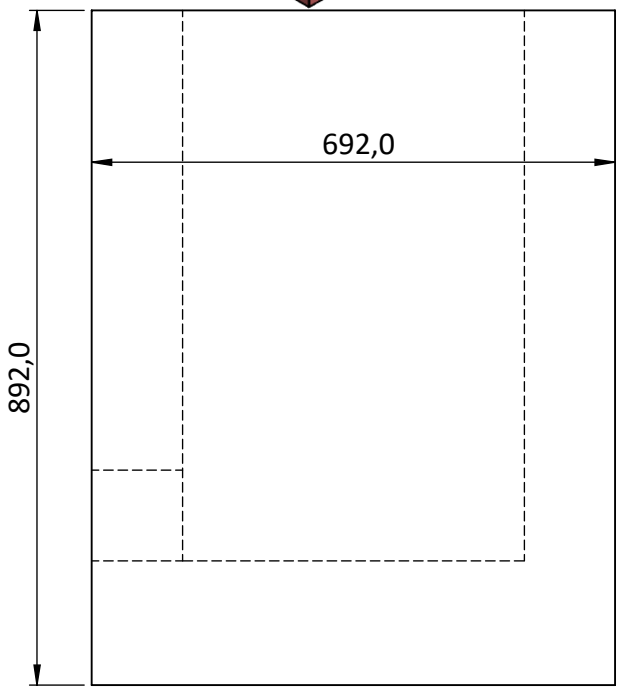
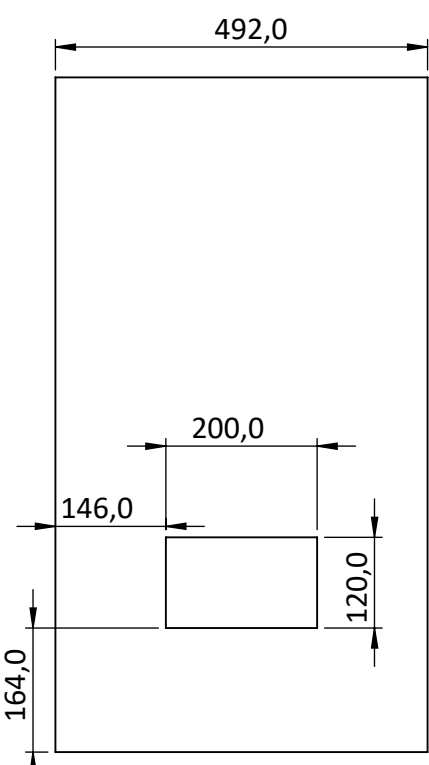
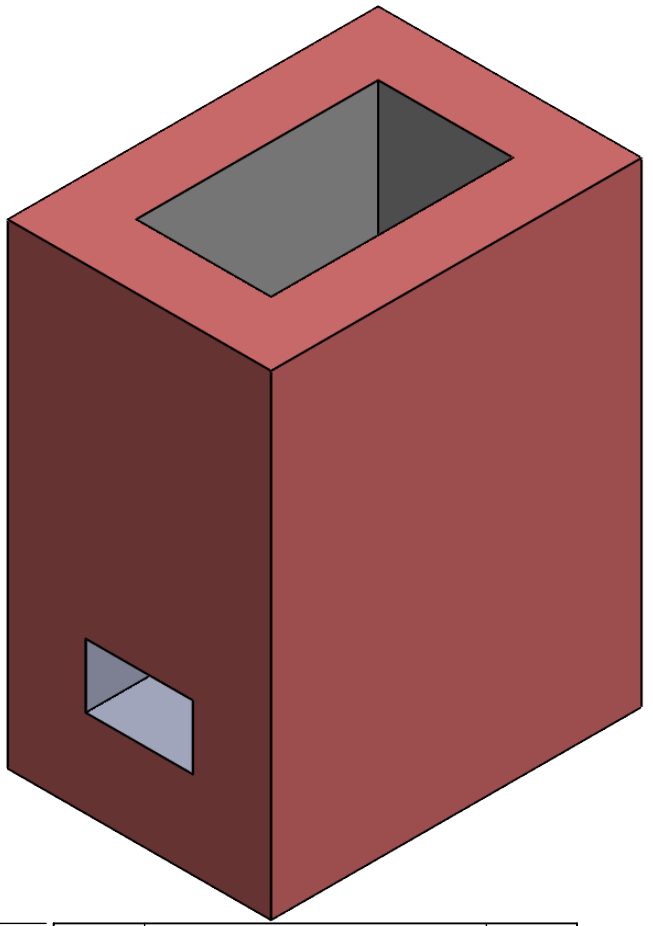
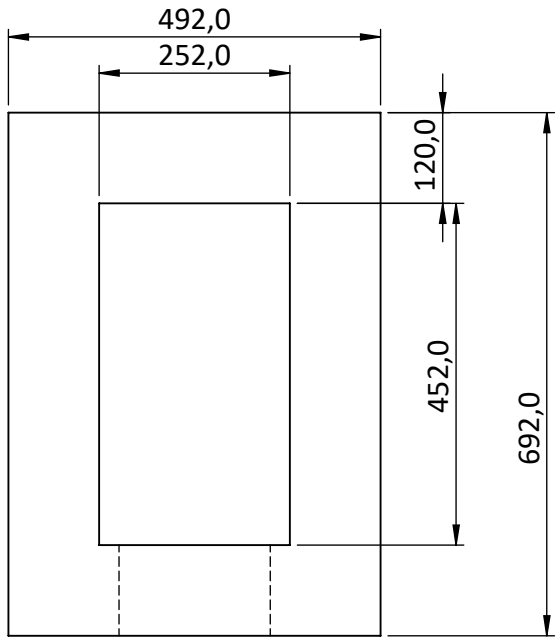

| JML                              | NAMA BAGIAN |      |      |      |      | BAHAN | UKURAN JADI       | UKURAN KASAR | NO. ID     | KETERANGAN |  |
|----------------------------------|-------------|------|------|------|------|-------|-------------------|--------------|------------|------------|--|
| >                                | 0           | 6    | 30   | 120  | 400  | 1000  | Pengerjaan Lanjut | NO. ORDER    |            |            |  |
| <                                | 6           | 30   | 120  | 400  | 1000 | 2000  |                   |              |            |            |  |
| TOL                              | ±0.1        | ±0.2 | ±0.3 | ±0.5 | ±0.8 | ±1.2  |                   |              |            |            |  |
| lapisan bata                     |             |      |      |      |      |       |                   | SKALA        | DIGAMBAR   |            |  |
|                                  |             |      |      |      |      |       |                   | 1:10         | DIPERIKSA  |            |  |
|                                  |             |      |      |      |      |       |                   |              | DISAHKAN   |            |  |
|                                  |             |      |      |      |      |       |                   | FORMAT       | NO. GAMBAR |            |  |
| <b>POLITEKNIK NEGERI CILACAP</b> |             |      |      |      |      |       |                   | <b>A4</b>    |            |            |  |

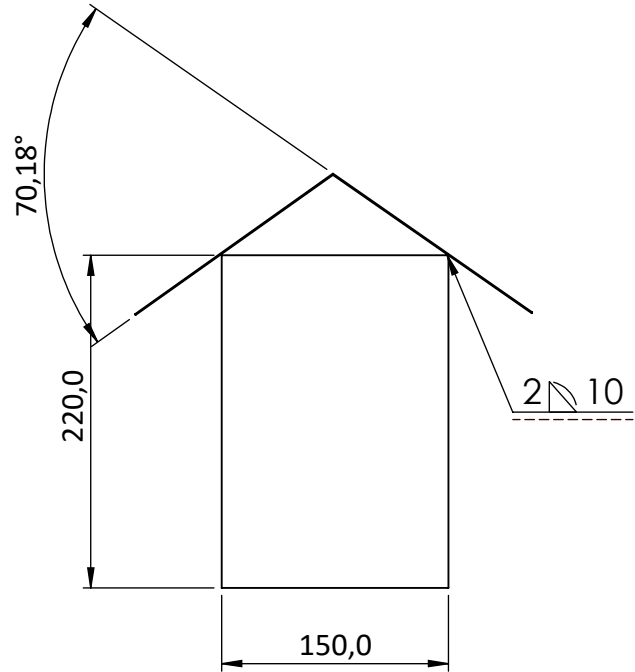
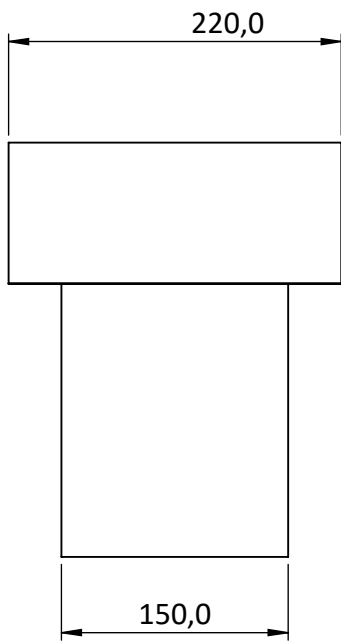
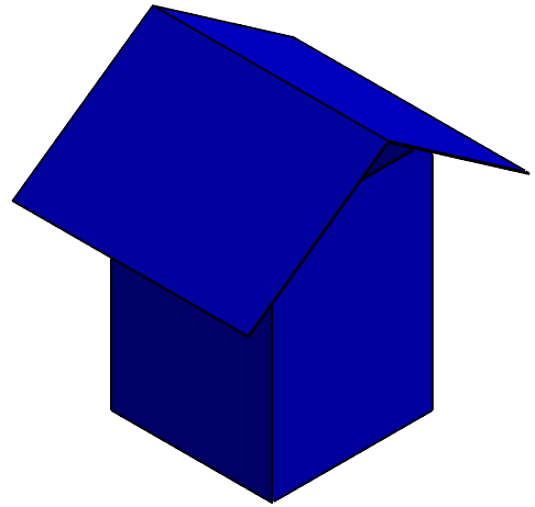
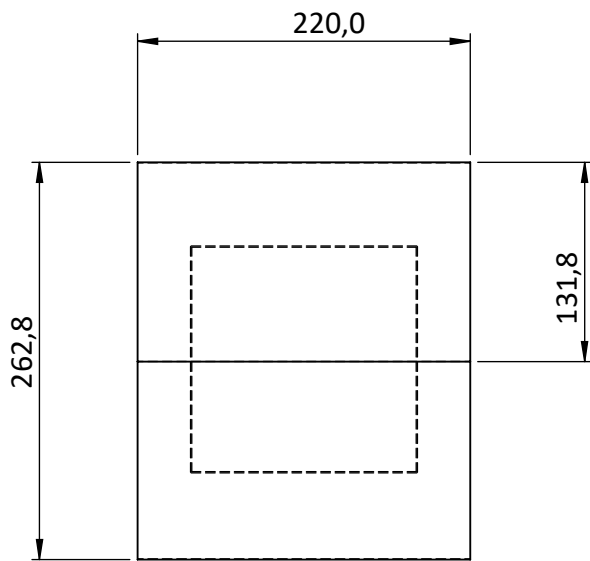

| JML                              | NAMA BAGIAN |      |      |      |      |      | BAHAN             | UKURAN JADI | UKURAN KASAR        | NO. ID     | KETERANGAN |
|----------------------------------|-------------|------|------|------|------|------|-------------------|-------------|---------------------|------------|------------|
| >                                | 0           | 6    | 30   | 120  | 400  | 1000 | Pengerjaan Lanjut |             | NO. ORDER           |            |            |
| <                                | 6           | 30   | 120  | 400  | 1000 | 2000 |                   |             |                     |            |            |
| TOL                              | ±0.1        | ±0.2 | ±0.3 | ±0.5 | ±0.8 | ±1.2 |                   |             |                     |            |            |
| cerobong asap                    |             |      |      |      |      |      |                   |             | SKALA<br>1:5        | DIGAMBAR   |            |
|                                  |             |      |      |      |      |      |                   |             | DIPERIKSA           |            |            |
|                                  |             |      |      |      |      |      |                   |             | DISAHKAN            |            |            |
| <b>POLITEKNIK NEGERI CILACAP</b> |             |      |      |      |      |      |                   |             | FORMAT<br><b>A4</b> | NO. GAMBAR |            |

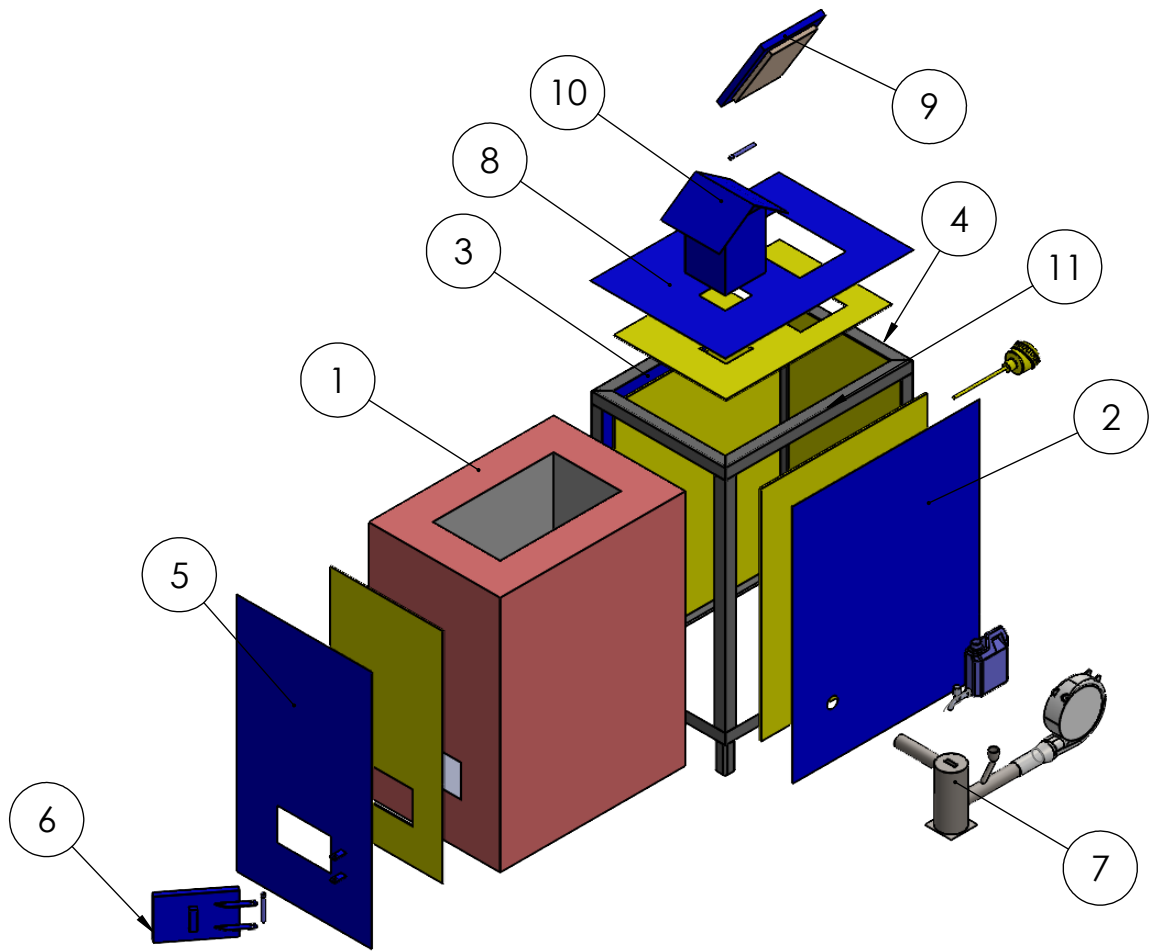

| ITEM NO. | PART NUMBER                      | QTY. |
|----------|----------------------------------|------|
| 1        | Lapisan bata dan semen           | 1    |
| 2        | casing incinirator samping kiri  | 1    |
| 3        | casing incinirator samping kanan | 1    |
| 4        | casing incinirator belakang      | 1    |
| 5        | casing incinirator depan         | 1    |
| 6        | pintu incinerator bawah          | 1    |
| 7        | Sub assy burner                  | 1    |
| 8        | casing incinerator atas          | 1    |
| 9        | pintu incinerator atas           | 1    |
| 10       | cerobong asap                    | 1    |
| 11       | rangka utama incinerator         | 1    |

| JML | NAMA BAGIAN |      |      |      |      | BAHAN | UKURAN JADI       | UKURAN KASAR | NO. ID | KETERANGAN |
|-----|-------------|------|------|------|------|-------|-------------------|--------------|--------|------------|
| >   | 0           | 6    | 30   | 120  | 400  | 1000  | Pengerjaan Lanjut | NO. ORDER    |        |            |
| <   | 6           | 30   | 120  | 400  | 1000 | 2000  |                   |              |        |            |
| TOL | ±0.1        | ±0.2 | ±0.3 | ±0.5 | ±0.8 | ±1.2  |                   |              |        |            |

|                             |       |           |  |  |
|-----------------------------|-------|-----------|--|--|
| <i>Assembly incinerator</i> | SKALA | DIGAMBAR  |  |  |
|                             | 1:20  | DIPERIKSA |  |  |
|                             |       | DISAHKAN  |  |  |

|                                  |                     |            |
|----------------------------------|---------------------|------------|
| <b>POLITEKNIK NEGERI CILACAP</b> | FORMAT<br><b>A4</b> | NO. GAMBAR |
|----------------------------------|---------------------|------------|

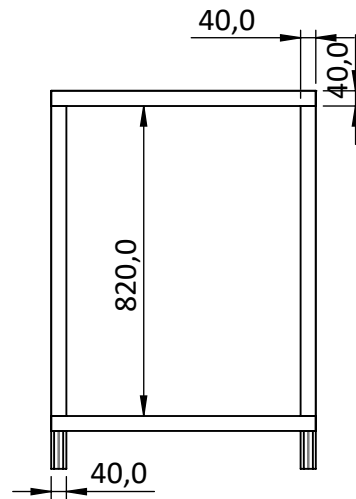
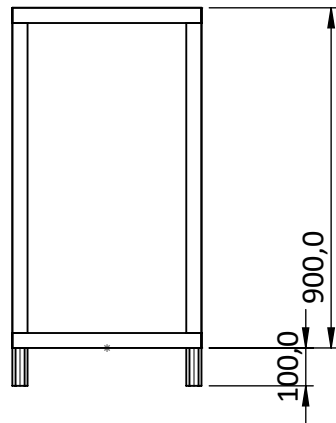
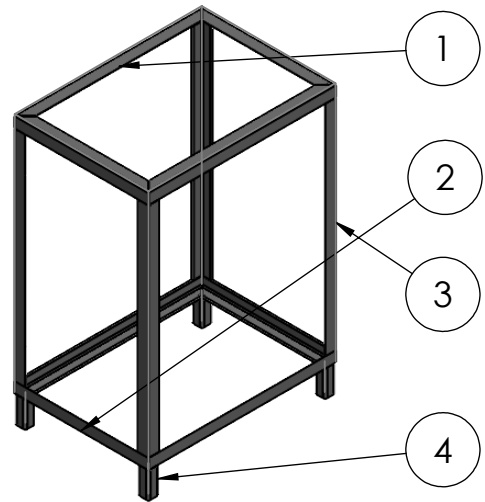
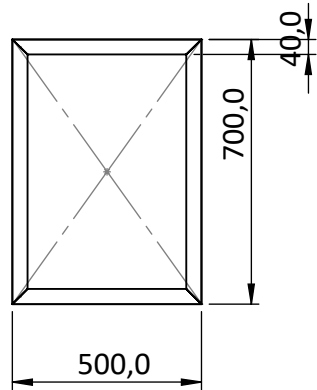

| ITEM NO. | QTY. | DESCRIPTION                       | LENGTH |
|----------|------|-----------------------------------|--------|
| 1        | 4    | L 40,00 X 40,00 X 4,000           | 700    |
| 2        | 4    | L 40,00 X 40,00 X 4,000           | 500    |
| 3        | 4    | L 40,00 X 40,00 X 4,000           | 827.76 |
| 4        | 4    | TUBE, SQUARE 40,00 X 40,00 X 4,00 | 100    |

| JML                              | NAMA BAGIAN |      |      |      |      | BAHAN | UKURAN JADI       | UKURAN KASAR | NO. ID     | KETERANGAN |  |
|----------------------------------|-------------|------|------|------|------|-------|-------------------|--------------|------------|------------|--|
| >                                | 0           | 6    | 30   | 120  | 400  | 1000  | Pengerjaan Lanjut | NO. ORDER    | PROYEKSI   |            |  |
| <                                | 6           | 30   | 120  | 400  | 1000 | 2000  |                   |              |            |            |  |
| TOL                              | ±0.1        | ±0.2 | ±0.3 | ±0.5 | ±0.8 | ±1.2  |                   |              |            |            |  |
| Rangka                           |             |      |      |      |      |       |                   | SKALA        | DIGAMBAR   |            |  |
|                                  |             |      |      |      |      |       |                   | 1:20         | DIPERIKSA  |            |  |
|                                  |             |      |      |      |      |       |                   |              | DISAHKAN   |            |  |
|                                  |             |      |      |      |      |       |                   |              |            |            |  |
| <b>POLITEKNIK NEGERI CILACAP</b> |             |      |      |      |      |       |                   | FORMAT       | NO. GAMBAR |            |  |
|                                  |             |      |      |      |      |       |                   | <b>A4</b>    |            |            |  |

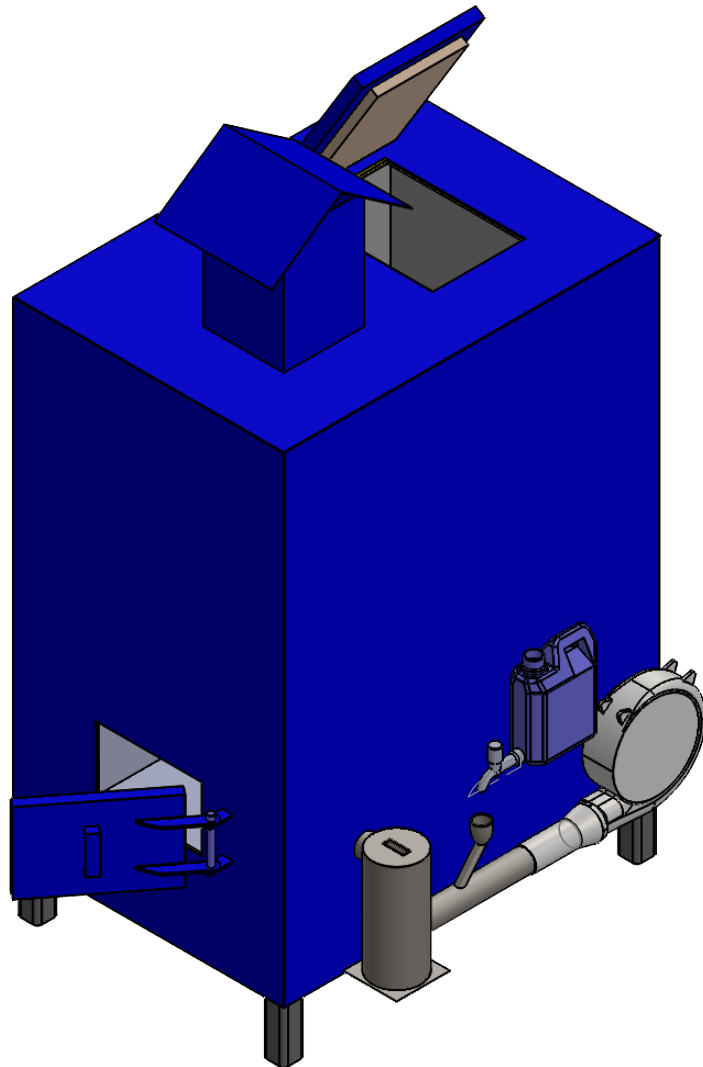

| JML  | NAMA BAGIAN |      |      |      |      |      | BAHAN             | UKURAN JADI | UKURAN KASAR        | NO. ID       | KETERANGAN |
|--|-------------|------|------|------|------|------|-------------------|-------------|---------------------|--------------|------------|
| >  | 0           | 6    | 30   | 120  | 400  | 1000 | Pengerjaan Lanjut | NO. ORDER   |                     | PROYEKSI<br> |            |
| <  | 6           | 30   | 120  | 400  | 1000 | 2000 |                   |             |                     |              |            |
| TOL  | ±0.1        | ±0.2 | ±0.3 | ±0.5 | ±0.8 | ±1.2 |                   |             |                     |              |            |
| <i>incinerator</i>   |             |      |      |      |      |      |                   |             | SKALA<br>1:10       | DIGAMBAR     |            |
|  |             |      |      |      |      |      |                   |             | DIPERIKSA           |              |            |
|  |             |      |      |      |      |      |                   |             | DISAHKAN            |              |            |
|  <b>POLITEKNIK NEGERI CILACAP</b> |             |      |      |      |      |      |                   |             | FORMAT<br><b>A4</b> | NO. GAMBAR   |            |

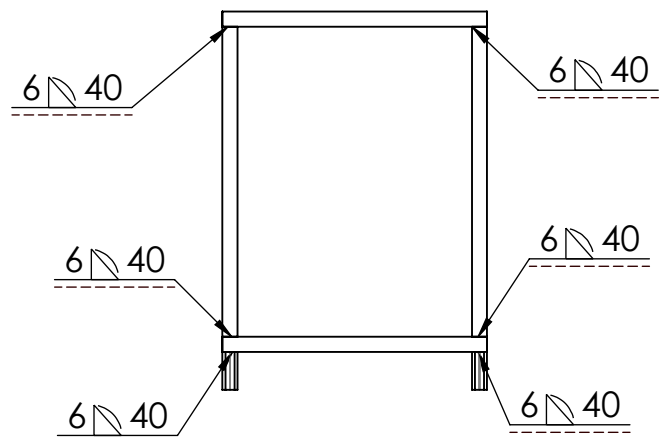
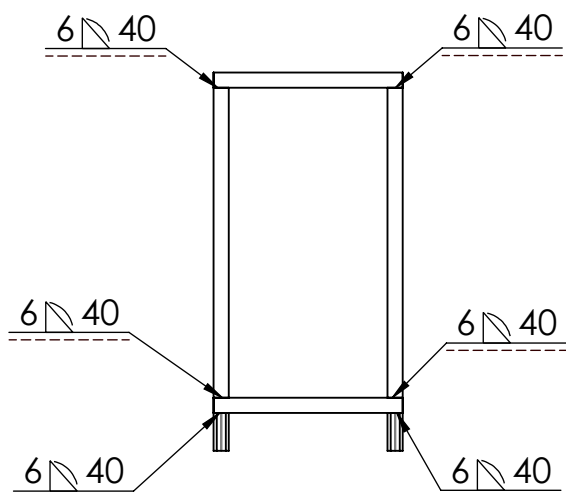
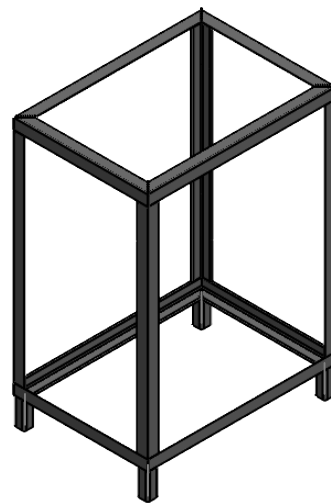
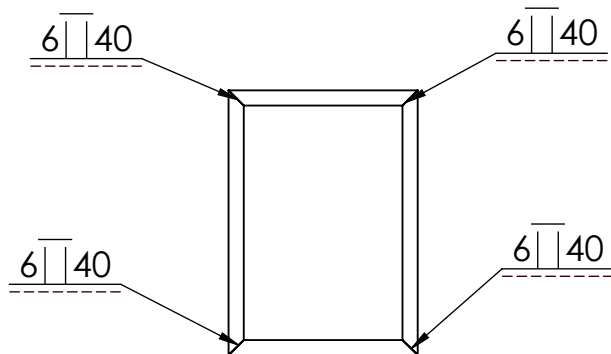

| JML                              | NAMA BAGIAN |      |      |      |      |      | BAHAN             | UKURAN JADI | UKURAN KASAR | NO. ID       | KETERANGAN |  |
|----------------------------------|-------------|------|------|------|------|------|-------------------|-------------|--------------|--------------|------------|--|
| >                                | 0           | 6    | 30   | 120  | 400  | 1000 | Pengerjaan Lanjut | NO. ORDER   |              | PROYEKSI<br> |            |  |
| <                                | 6           | 30   | 120  | 400  | 1000 | 2000 |                   |             |              |              |            |  |
| TOL                              | ±0.1        | ±0.2 | ±0.3 | ±0.5 | ±0.8 | ±1.2 |                   |             |              |              |            |  |
| Rangka                           |             |      |      |      |      |      |                   |             | SKALA        | DIGAMBAR     |            |  |
|                                  |             |      |      |      |      |      |                   |             | 1:20         | DIPERIKSA    |            |  |
|                                  |             |      |      |      |      |      |                   |             |              | DISAHKAN     |            |  |
| <b>POLITEKNIK NEGERI CILACAP</b> |             |      |      |      |      |      |                   |             | FORMAT       | NO. GAMBAR   |            |  |
|                                  |             |      |      |      |      |      |                   |             | <b>A4</b>    |              |            |  |



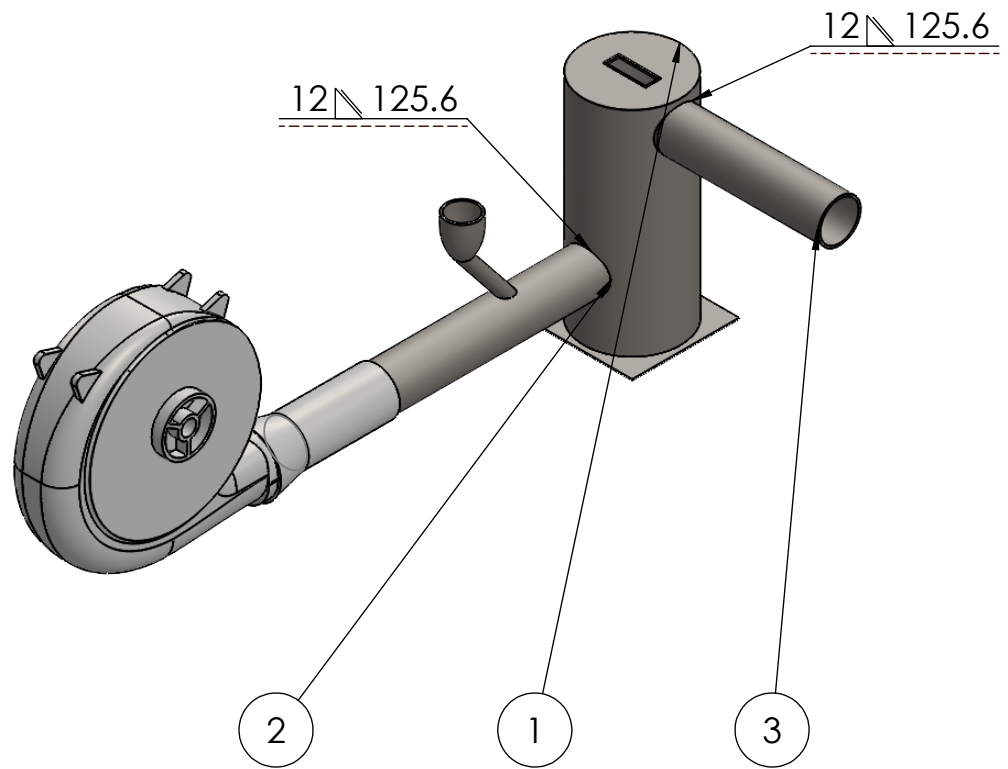

| ITEM NO. | PART NUMBER   | QTY. |
|----------|---------------|------|
| 1        | burner        | 1    |
| 2        | pipa burner 2 | 1    |
| 3        | pipa burner 1 | 1    |

| JML                              | NAMA BAGIAN |      |      |      |      |      | BAHAN             | UKURAN JADI | UKURAN KASAR | NO. ID     | KETERANGAN |  |
|----------------------------------|-------------|------|------|------|------|------|-------------------|-------------|--------------|------------|------------|--|
| >                                | 0           | 6    | 30   | 120  | 400  | 1000 | Pengerjaan Lanjut |             | NO. ORDER    |            |            |  |
| <                                | 6           | 30   | 120  | 400  | 1000 | 2000 |                   |             |              |            |            |  |
| TOL                              | ±0.1        | ±0.2 | ±0.3 | ±0.5 | ±0.8 | ±1.2 |                   |             |              |            |            |  |
| Sub assy burner                  |             |      |      |      |      |      |                   |             | SKALA        | DIGAMBAR   |            |  |
|                                  |             |      |      |      |      |      |                   |             | 1:5          | DIPERIKSA  |            |  |
|                                  |             |      |      |      |      |      |                   |             |              | DISAHKAN   |            |  |
|                                  |             |      |      |      |      |      |                   |             |              |            |            |  |
| <b>POLITEKNIK NEGERI CILACAP</b> |             |      |      |      |      |      |                   |             | FORMAT       | NO. GAMBAR |            |  |
|                                  |             |      |      |      |      |      |                   |             | <b>A4</b>    |            |            |  |

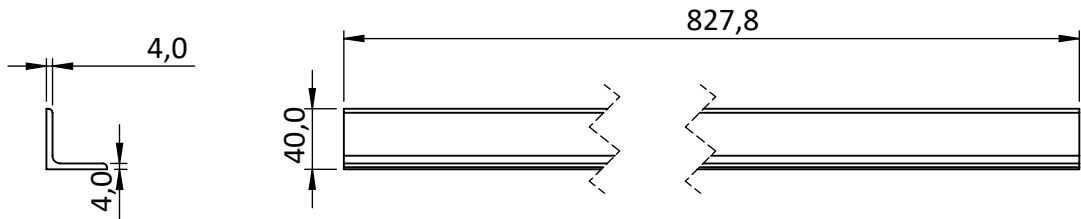
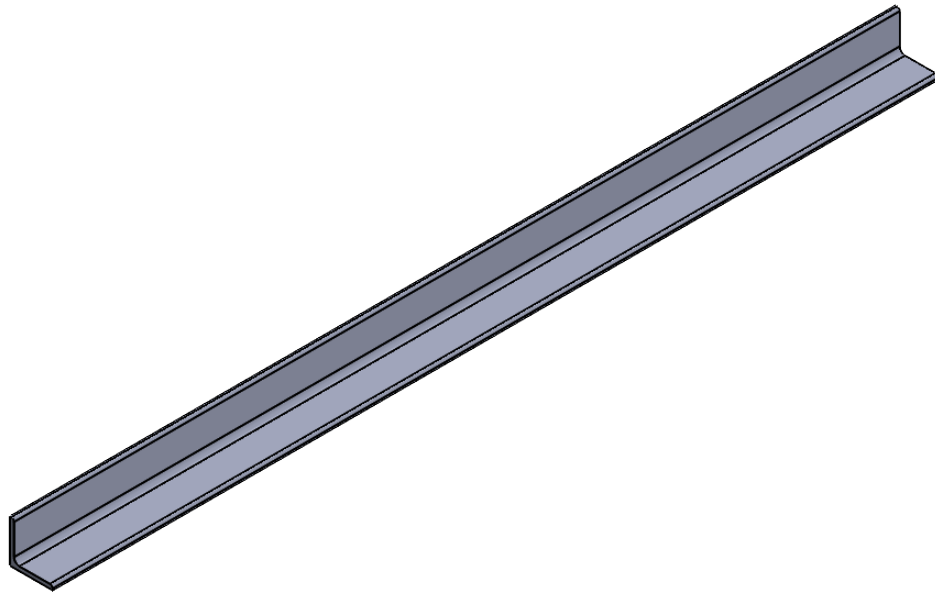

| JML                              | NAMA BAGIAN |      |      |      |      |      | BAHAN             | UKURAN JADI | UKURAN KASAR | NO. ID       | KETERANGAN |
|----------------------------------|-------------|------|------|------|------|------|-------------------|-------------|--------------|--------------|------------|
| >                                | 0           | 6    | 30   | 120  | 400  | 1000 | Pengerjaan Lanjut | NO. ORDER   |              | PROYEKSI<br> |            |
| <                                | 6           | 30   | 120  | 400  | 1000 | 2000 |                   |             |              |              |            |
| TOL                              | ±0.1        | ±0.2 | ±0.3 | ±0.5 | ±0.8 | ±1.2 |                   |             |              |              |            |
| Rangka siku 827.76mm             |             |      |      |      |      |      |                   |             | SKALA        | DIGAMBAR     |            |
|                                  |             |      |      |      |      |      |                   |             | 1:5          | DIPERIKSA    |            |
|                                  |             |      |      |      |      |      |                   |             |              | DISAHKAN     |            |
| <b>POLITEKNIK NEGERI CILACAP</b> |             |      |      |      |      |      |                   |             | FORMAT       | NO. GAMBAR   |            |
|                                  |             |      |      |      |      |      |                   |             | <b>A4</b>    |              |            |

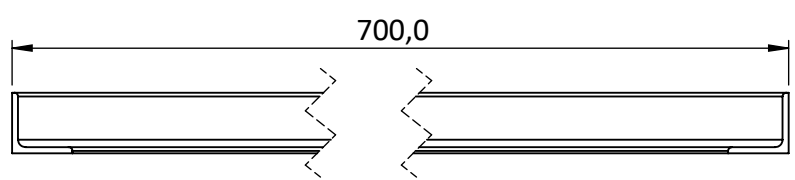
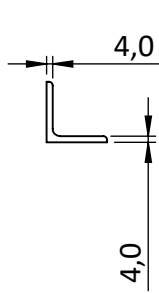
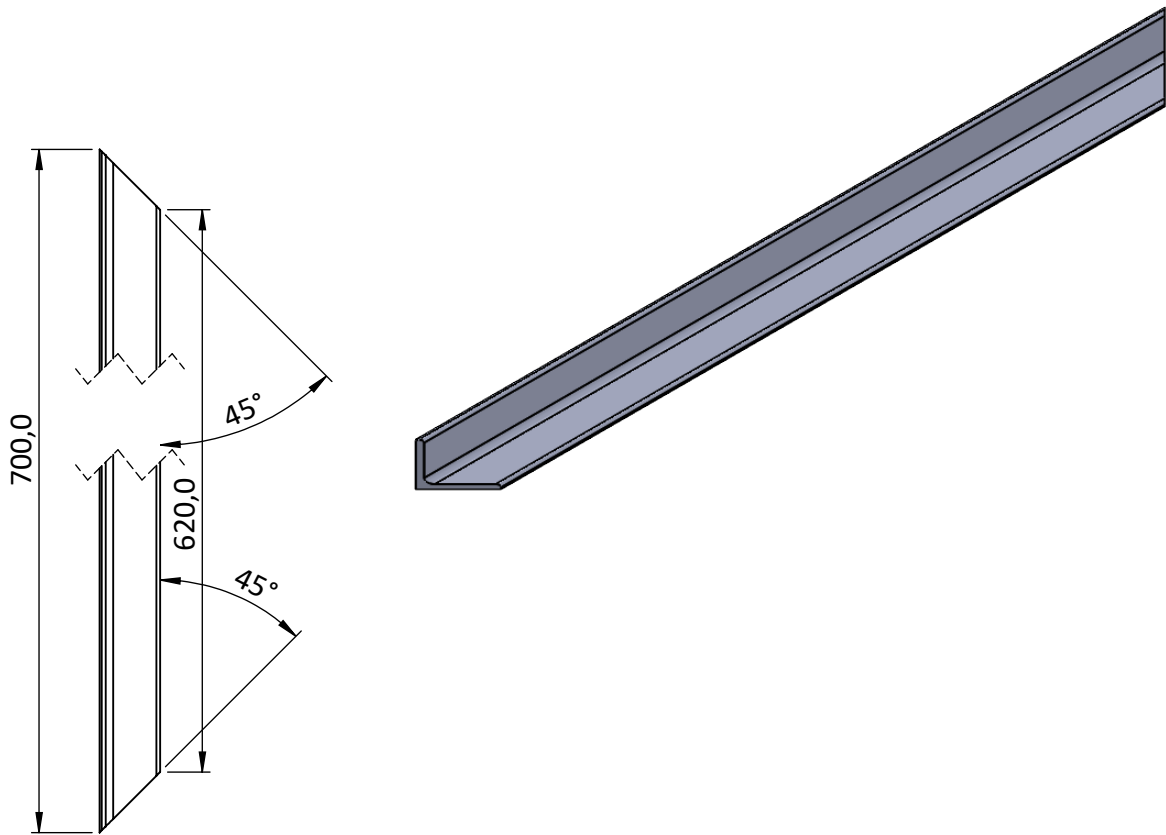

| JML                              | NAMA BAGIAN |      |      |      |      |      | BAHAN             | UKURAN JADI | UKURAN KASAR        | NO. ID     | KETERANGAN |
|----------------------------------|-------------|------|------|------|------|------|-------------------|-------------|---------------------|------------|------------|
| >                                | 0           | 6    | 30   | 120  | 400  | 1000 | Pengerjaan Lanjut |             | NO. ORDER           | PROYEKSI   |            |
| <                                | 6           | 30   | 120  | 400  | 1000 | 2000 |                   |             |                     |            |            |
| TOL                              | ±0.1        | ±0.2 | ±0.3 | ±0.5 | ±0.8 | ±1.2 |                   |             |                     |            |            |
| Rangka siku 700mm                |             |      |      |      |      |      |                   |             | SKALA<br>1:5        | DIGAMBAR   |            |
|                                  |             |      |      |      |      |      |                   |             | DIPERIKSA           |            |            |
|                                  |             |      |      |      |      |      |                   |             | DISAHKAN            |            |            |
| <b>POLITEKNIK NEGERI CILACAP</b> |             |      |      |      |      |      |                   |             | FORMAT<br><b>A4</b> | NO. GAMBAR |            |

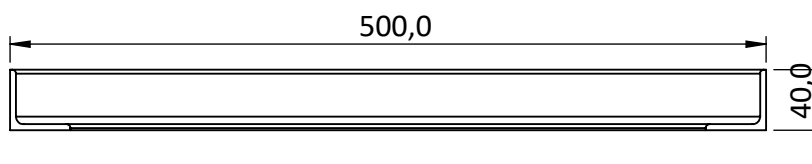
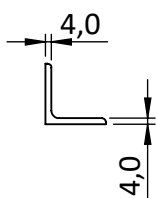
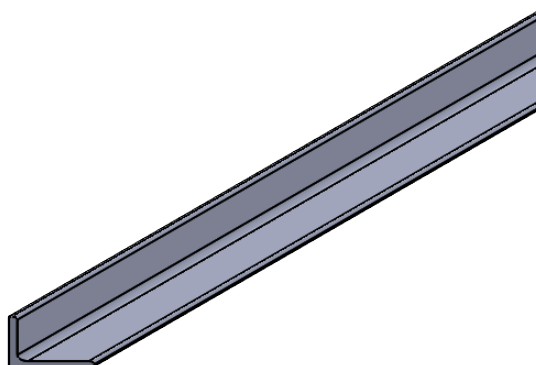
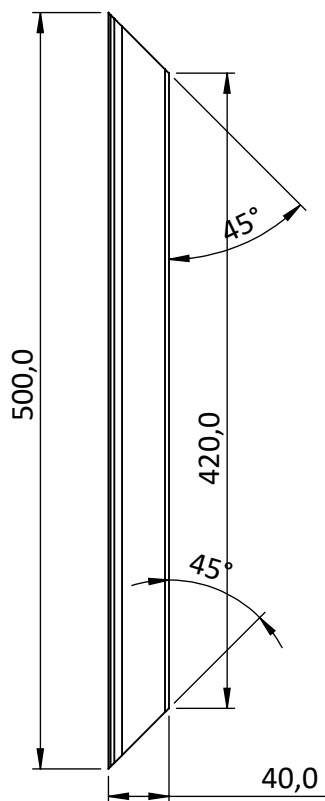

| JML               | NAMA BAGIAN |      |      |      |      |      | BAHAN             | UKURAN JADI | UKURAN KASAR                     | NO. ID    | KETERANGAN |
|-------------------|-------------|------|------|------|------|------|-------------------|-------------|----------------------------------|-----------|------------|
| >                 | 0           | 6    | 30   | 120  | 400  | 1000 | Pengerjaan Lanjut |             | NO. ORDER                        |           |            |
| <                 | 6           | 30   | 120  | 400  | 1000 | 2000 |                   |             |                                  |           |            |
| TOL               | ±0.1        | ±0.2 | ±0.3 | ±0.5 | ±0.8 | ±1.2 |                   |             |                                  |           |            |
| Rangka siku 500mm |             |      |      |      |      |      |                   |             | SKALA                            | DIGAMBAR  |            |
|                   |             |      |      |      |      |      |                   |             | 1:5                              | DIPERIKSA |            |
|                   |             |      |      |      |      |      |                   |             |                                  | DISAHKAN  |            |
|                   |             |      |      |      |      |      |                   |             | <b>POLITEKNIK NEGERI CILACAP</b> |           |            |
|                   |             |      |      |      |      |      |                   |             | <b>A4</b>                        |           |            |

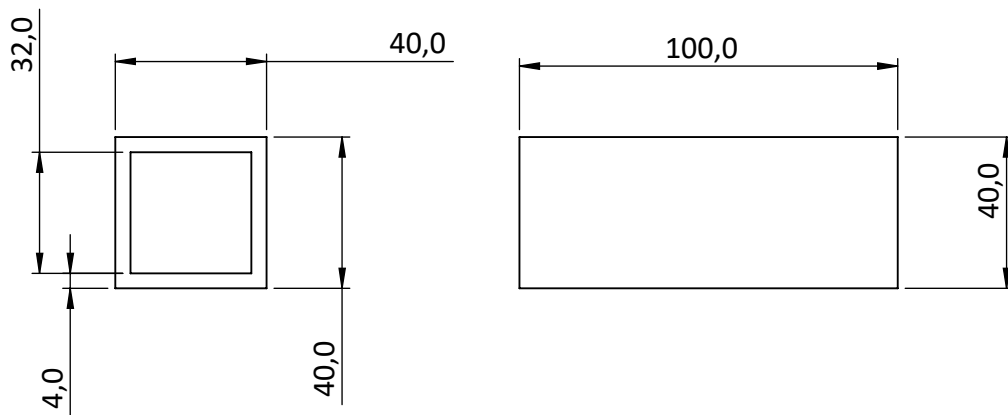
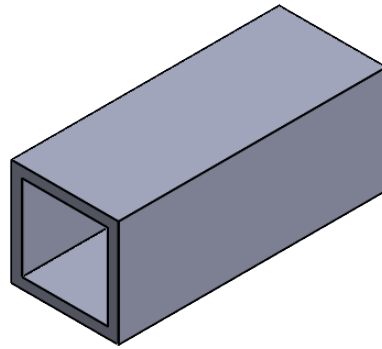

| JML                              | NAMA BAGIAN |      |      |      |      |      | BAHAN             | UKURAN JADI         | UKURAN KASAR | NO. ID       | KETERANGAN |
|----------------------------------|-------------|------|------|------|------|------|-------------------|---------------------|--------------|--------------|------------|
| >                                | 0           | 6    | 30   | 120  | 400  | 1000 | PENGERJAAN LANJUT | NO. ORDER           |              | PROYEKSI<br> |            |
| <                                | 6           | 30   | 120  | 400  | 1000 | 2000 |                   |                     |              |              |            |
| TOL                              | ±0.1        | ±0.2 | ±0.3 | ±0.5 | ±0.8 | ±1.2 |                   |                     |              |              |            |
| Rangka hollow 100mm              |             |      |      |      |      |      |                   | SKALA<br>1:2        | DIGAMBAR     |              |            |
|                                  |             |      |      |      |      |      |                   |                     | DIPERIKSA    |              |            |
|                                  |             |      |      |      |      |      |                   |                     | DISAHKAN     |              |            |
|                                  |             |      |      |      |      |      |                   |                     |              |              |            |
| <b>POLITEKNIK NEGERI CILACAP</b> |             |      |      |      |      |      |                   | FORMAT<br><b>A4</b> | NO. GAMBAR   |              |            |

**LAMPIRAN 1**  
**(DOKUMENTASI PROSES PRODUKSI)**

## DOKUMENTASI KEGIATAN



**LAMPIRAN 2**  
**(ALUR PROSES ALAT *INCINERATOR*)**



**ALUR PROSES  
ALAT INCINERATOR**

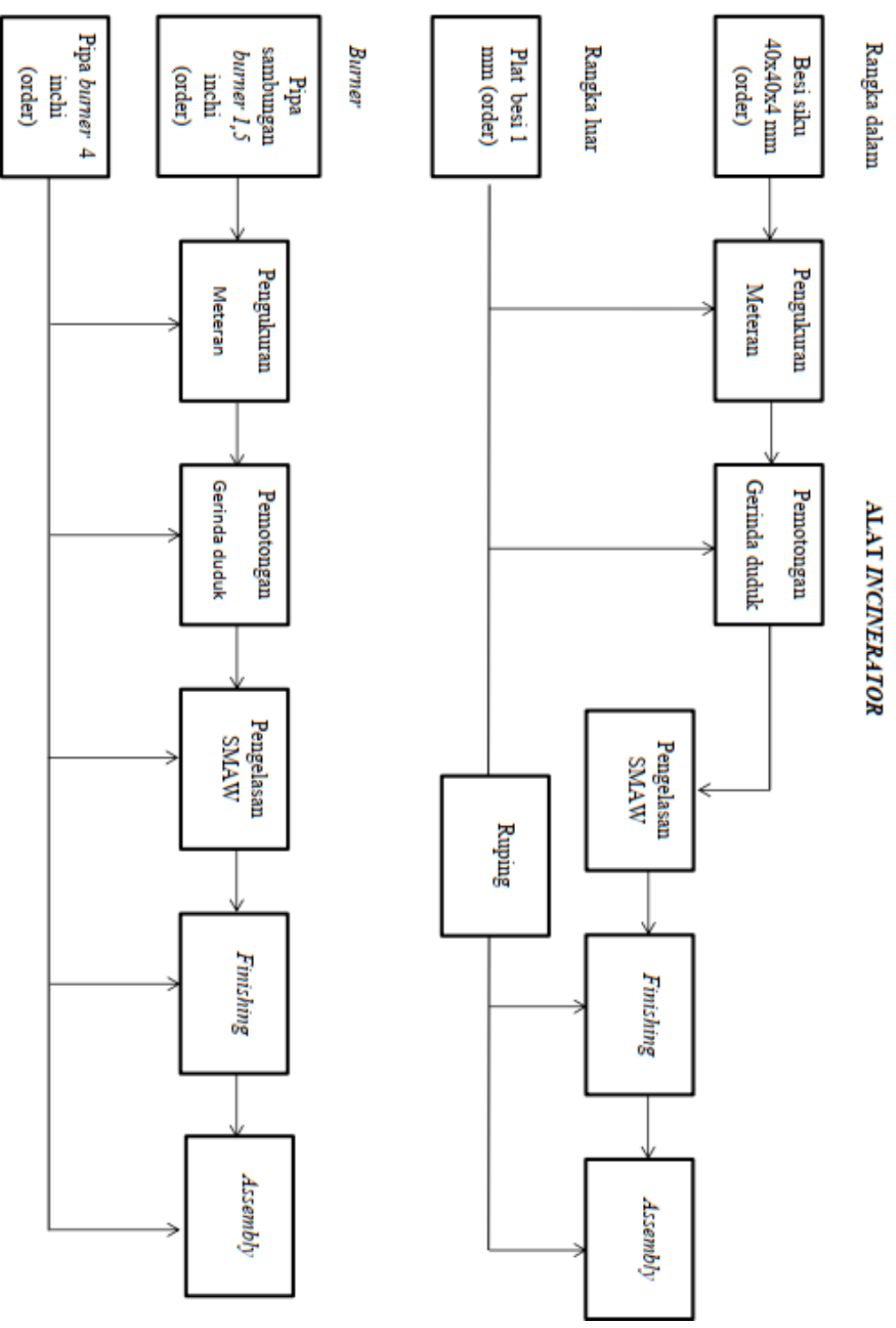

Dinding tungku

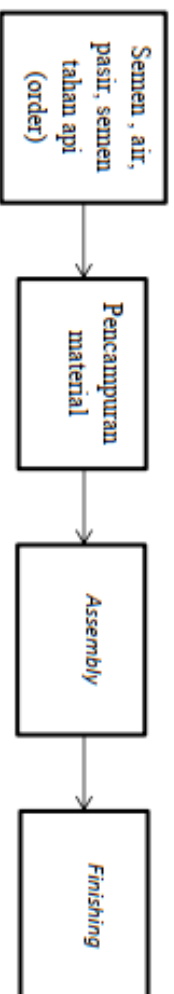

Cerobong asap

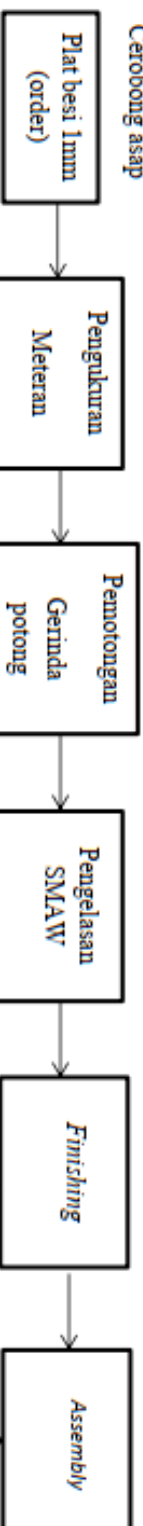

Pintu



Kelistrikan

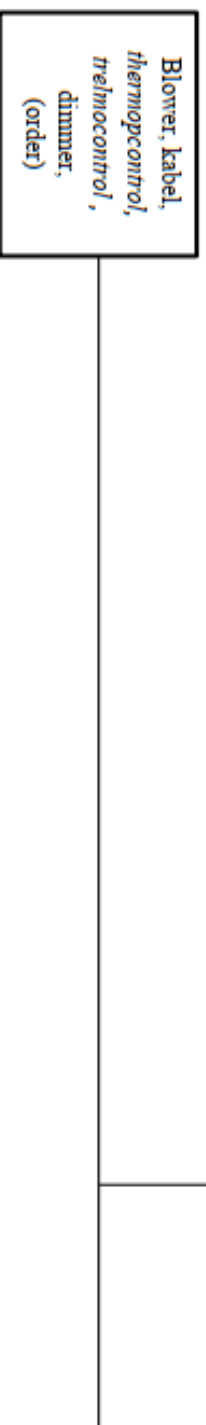

**LAMPIRAN 3**  
**(DOKUMENTASI UJI FUNGSI)**

## DOKUMENTASI UJI HASIL



**LAMPIRAN 4**  
**(BIODATA PENULIS)**

## BIODATA PENULIS



Nama : Avanka Frezzy Nandestra  
Tempat, tanggal lahir : Cilacap, 28 November 2001  
NIM : 200103027  
Prodi : D3-Teknik Mesin  
Jurusan : Rekayasa Mesin Dan Industri Pertanian  
Alama : Jalan Pasir Emas RT 06 RW 15 Cilacap, Kec. Cilacap  
Selatan, Kab. Cilacap  
*Telephone/HP* : 081328471651  
e-mail : Presiavanka28@gmail.com  
Hobi : Sepak bola, memancing, dan mendaki gunung  
Motto : Jika bukan hari ini maka hari esok jadi jangan pernah  
menyerah kawan dan gapailah cita-citamu.

### **Riwayat Pendidikan:**

1. SD Negeri Cilacap10 : Tahun 2008-2014
2. SMP Negeri 8 Cilacap : Tahun 2014-2017
3. SMK Budi Utomo Cilacap : Tahun 2017-2020